

DATA SHEET

TDA3618AJR

Multiple voltage regulator with
switch and ignition buffers

Product specification
File under Integrated Circuits, IC01

2001 May 02

Multiple voltage regulator with switch and ignition buffers

TDA3618AJR

FEATURES

General

- Extremely low noise behaviour and good stability with very small output capacitors
- Two V_P -state controlled regulators and a power switch
- Regulator 2, reset and ignition buffer operate during load dump and thermal shutdown
- Separate control pins for switching regulator 1, regulator 3 and the power switch
- Supply voltage range from -18 to $+50$ V
- Low reverse current of regulator 2
- Low quiescent current when regulator 1, regulator 3 and the power switch are switched off
- Hold output for low V_P
- Hold output for regulators 1 and 3
- Hold output for foldback mode switch
- Hold output for load dump and temperature protection
- Reset (push-pull) and hold (open collector) outputs
- Adjustable reset delay time
- High ripple rejection
- Backup capacitor for regulator 2
- Two independent ignition buffers, one inverted and with open collector output.

Protection

- Reverse polarity safe, down to -18 V
- Able to withstand voltages up to 18 V at the outputs (supply line may be short-circuited)
- ESD protected on all pins
- Thermal protections with hysteresis
- Load dump protection

- Foldback current limit protection for regulators 1, 2 and 3
- Delayed second current limit protection for the power switch at short-circuit
- The regulator outputs and the power switch are DC short-circuit safe to ground and V_P .

GENERAL DESCRIPTION

The TDA3618AJR is a multiple output voltage regulator with a power switch and ignition buffers, intended for use in car radios with or without a microcontroller. It contains:

- Two fixed voltage regulators with foldback current protection (regulators 1 and 3) and one fixed voltage regulator (regulator 2) intended to supply a microcontroller, that also operates during load dump and thermal shutdown
- A power switch with protection, operated by an enable input
- Reset and hold outputs that can be used to interface with the microcontroller; the reset signal can be used to wake up the microcontroller
- A supply pin that can withstand load dump pulses and negative supply voltages
- Regulator 2, which is switched on at a backup voltage greater than 6.5 V and off when the output voltage of regulator 2 drops below 1.9 V
- A provision for the use of a reserve supply capacitor that will hold enough energy for regulator 2 (5 V continuous) to allow a microcontroller to prepare for loss of voltage
- An inverted ignition 1 input with open collector output stage
- An ignition 2 input Schmitt trigger with push-pull output stage.

ORDERING INFORMATION

| TYPE NUMBER | PACKAGE | | |
|-------------|---------|---|----------|
| | NAME | DESCRIPTION | VERSION |
| TDA3618AJR | DBS17P | plastic DIL-bent-SIL (specially bent) power package; 17 leads (lead length 12 mm) | SOT475-1 |

Multiple voltage regulator with switch and ignition buffers

TDA3618AJR

QUICK REFERENCE DATA

| SYMBOL | PARAMETER | CONDITIONS | MIN. | TYP. | MAX. | UNIT |
|---------------------------|--------------------------------|---|------|------|------|--------------------|
| Supply | | | | | | |
| V_P | supply voltage | operating | 11 | 14.4 | 18 | V |
| | | reverse polarity; non-operating | – | – | –18 | V |
| | | regulator 2 on | 2.4 | 14.4 | 50 | V |
| | | jump start; $t \leq 10$ minutes | – | – | 30 | V |
| | | load dump protection; $t \leq 50$ ms; $t_r \geq 2.5$ ms | – | – | 50 | V |
| $I_{q(\text{tot})}$ | total quiescent supply current | standby mode | – | 400 | 500 | μA |
| T_j | junction temperature | | – | – | 150 | $^{\circ}\text{C}$ |
| Voltage regulators | | | | | | |
| $V_{O(\text{REG}1)}$ | output voltage of regulator 1 | $1 \text{ mA} \leq I_{\text{REG}1} \leq 600 \text{ mA}$ | 8.5 | 9.0 | 9.5 | V |
| $V_{O(\text{REG}2)}$ | output voltage of regulator 2 | $0.5 \text{ mA} \leq I_{\text{REG}2} \leq 150 \text{ mA}; V_P = 14.4 \text{ V}$ | 4.75 | 5.0 | 5.25 | V |
| $V_{O(\text{REG}3)}$ | output voltage of regulator 3 | $1 \text{ mA} \leq I_{\text{REG}3} \leq 750 \text{ mA}$ | 4.75 | 5.0 | 5.25 | V |
| Power switch | | | | | | |
| V_{drop} | drop-out voltage | $I_{\text{SW}} = 1 \text{ A}$ | – | 0.45 | 0.70 | V |
| | | $I_{\text{SW}} = 1.8 \text{ A}$ | – | 1.0 | 1.8 | V |
| I_M | peak current | | 3 | – | – | A |

Multiple voltage regulator with switch and ignition buffers

TDA3618AJR

BLOCK DIAGRAM

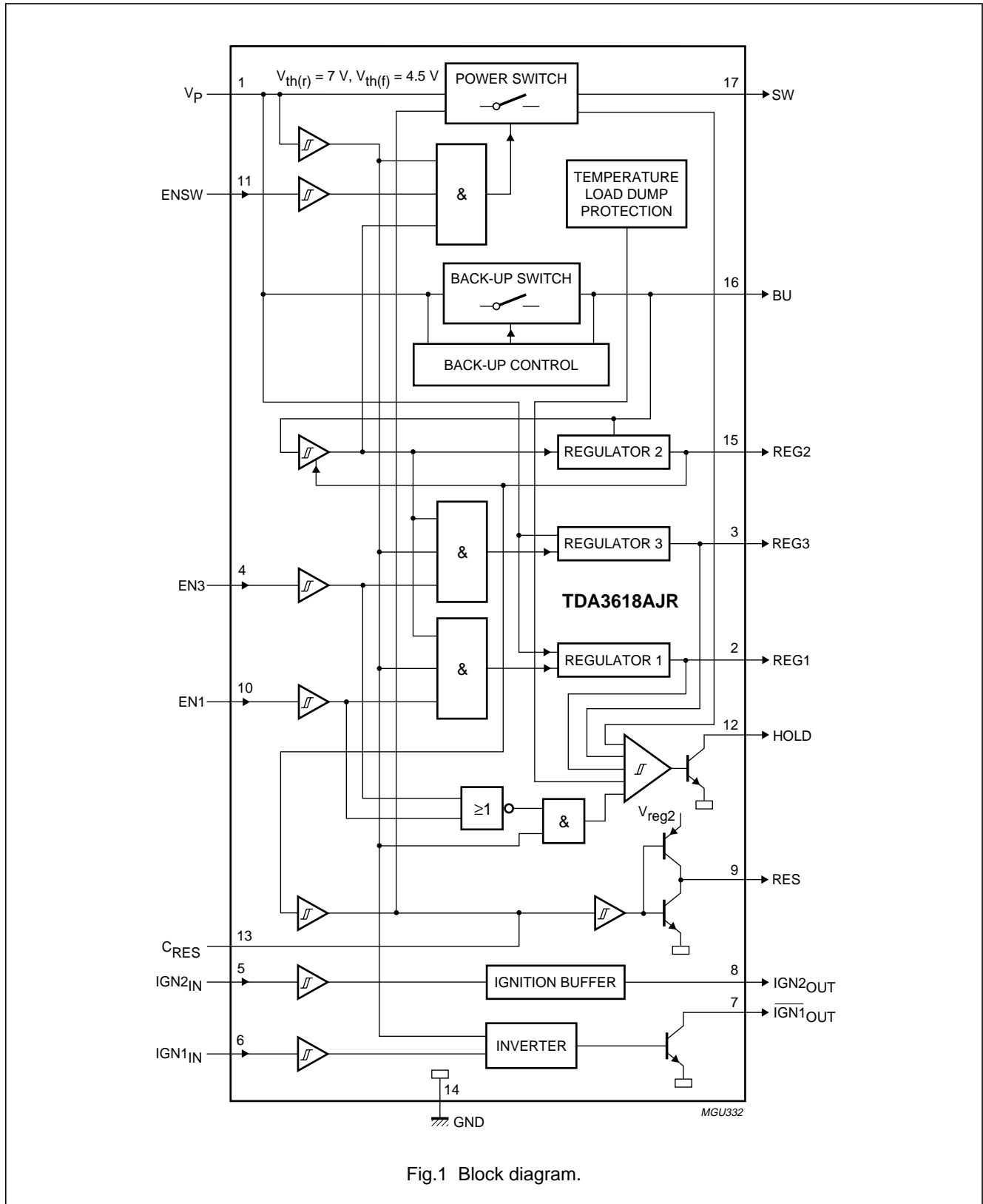

Fig.1 Block diagram.

Multiple voltage regulator with switch and ignition buffers

TDA3618AJR

PINNING

| SYMBOL | PIN | DESCRIPTION |
|---------------------|-----|--------------------------------|
| V _P | 1 | supply voltage |
| REG1 | 2 | regulator 1 output |
| REG3 | 3 | regulator 3 output |
| EN3 | 4 | enable input regulator 3 |
| IGN2 _{IN} | 5 | ignition 2 input |
| IGN1 _{IN} | 6 | ignition 1 input |
| IGN1 _{OUT} | 7 | ignition 1 output (active LOW) |
| IGN2 _{OUT} | 8 | ignition 2 output |
| RES | 9 | reset output (push-pull) |
| EN1 | 10 | enable input regulator 1 |
| ENSW | 11 | enable input power switch |
| HOLD | 12 | hold output (active LOW) |
| C _{RES} | 13 | reset delay capacitor |
| GND | 14 | ground |
| REG2 | 15 | regulator 2 output |
| BU | 16 | backup |
| SW | 17 | power switch output |

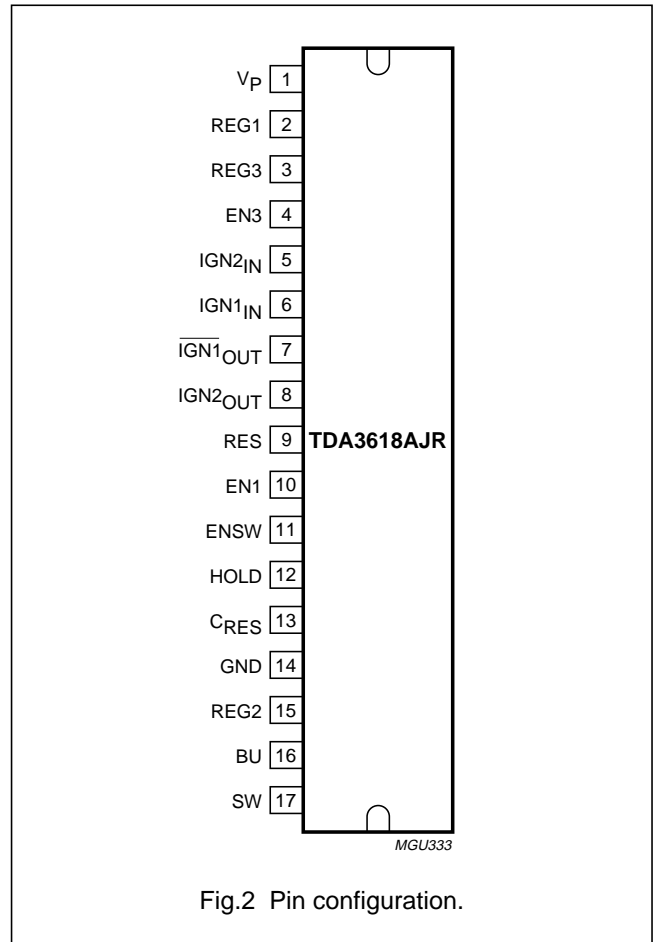

Fig.2 Pin configuration.

Multiple voltage regulator with switch and ignition buffers

TDA3618AJR

FUNCTIONAL DESCRIPTION

The TDA3618AJR is a multiple output voltage regulator with a power switch, intended for use in car radios with or without a microcontroller. Because of the low-voltage operation of the car radio, low-voltage drop regulators are used in the TDA3618AJR.

Regulator 2 switches on when the backup voltage exceeds 6.5 V for the first time and switches off again when the output voltage of regulator 2 falls below 1.9 V (this is far below an engine start). When regulator 2 is switched on and its output voltage is within its voltage range, the reset output is enabled to generate a reset to the microcontroller. The reset cycle can be extended by an external capacitor at pin C_{RES} . This start-up feature is included to secure a smooth start-up of the microcontroller at first connection, without uncontrolled switching of regulator 2 during the start-up sequence.

The charge of the backup capacitor can be used to supply regulator 2 for a short period when the supply drops to 0 V (the time depends on the value of the storage capacitor).

The output stages of regulators 1 and 3 have an extremely low noise behaviour and good stability. These regulators are stabilized by using small output capacitors.

When both regulator 2 and the supply voltage ($V_P > 4.5$ V) are available, regulators 1 and 3 can be operated by means of the enable inputs (pins EN1 and EN3 respectively).

Pin HOLD is normally HIGH and is active LOW. Pin HOLD is connected to an open collector NPN transistor and must have an external pull-up resistor to operate. The HOLD output is controlled by a LOW-voltage detection circuit which, when activated, pulls the warning output LOW (enabled). The detection outputs of the regulators are connected to an OR gate inside the IC such that the hold is activated (goes LOW) when the regulator voltages of regulator 1 and/or regulator 3 are out of regulation for any reason. Each regulator enable input controls its own detection circuit, such that if a regulator is disabled or switched off, the detection circuit for that regulator is disabled.

The hold circuit is also controlled by the temperature and load dump protection. Activating the temperature or load dump protection causes a hold (LOW) during the time the protection is activated. When all regulators are switched off, pin HOLD is controlled by the battery line (pin V_P), temperature protection and load dump protection.

The hold output is enabled (LOW) at low battery voltages. This indicates that it is not possible to get regulator 1 into regulation when switching it on. The hold function includes hysteresis to avoid oscillations when the regulator voltage crosses the hold threshold. Pin HOLD also becomes LOW when the switch is in foldback protection mode; see Fig.4 for a timing diagram. The hold circuit block diagram is given in Fig.3.

The power switch can also be controlled by means of a separate enable input (pin ENSW).

All output pins are fully protected. The regulators are protected against load dump (regulators 1 and 3 switch off at supply voltages >18 V) and short circuit (foldback current protection).

The switch contains a current protection. However, this protection is delayed at short-circuit by the reset delay capacitor. During this time, the output current is limited to a peak value of at least 3 and 2 A continuous ($V_P \leq 18$ V).

In the normal situation, the voltage on the reset delay capacitor is approximately 3.5 V (depending on temperature). The switch output is approximately $V_P - 0.4$ V. At operational temperature, the switch can deliver at least 3 A. At high temperature, the switch can deliver approximately 2 A. During an overload condition or short-circuit ($V_{SW} < V_P - 3.7$ V), the voltage on the reset delay capacitor rises 0.6 V above the voltage of regulator 2. This rise time depends on the capacitor connected to pin C_{RES} . During this time, the switch can deliver more than 3 A. The charge current of the reset delay capacitor is typically 4 μ A and the voltage swing approximately 1.5 V. When regulator 2 is out of regulation and generates a reset, the switch can only deliver 2 A and will go into foldback protection without delay. At supply voltages >17 V, the switch is clamped at 16 V maximum (to avoid externally connected circuits being damaged by an overvoltage) and the switch will switch off at load dump.

Interfacing with the microcontroller (simple full/semi on/off logic applications) can be realized with two independent ignition Schmitt triggers and ignition output buffers (one open collector and one push-pull output). Ignition 1 output is inverted.

The total timing diagrams are shown in Figs 4 and 5.

Multiple voltage regulator with switch and ignition buffers

TDA3618AJR

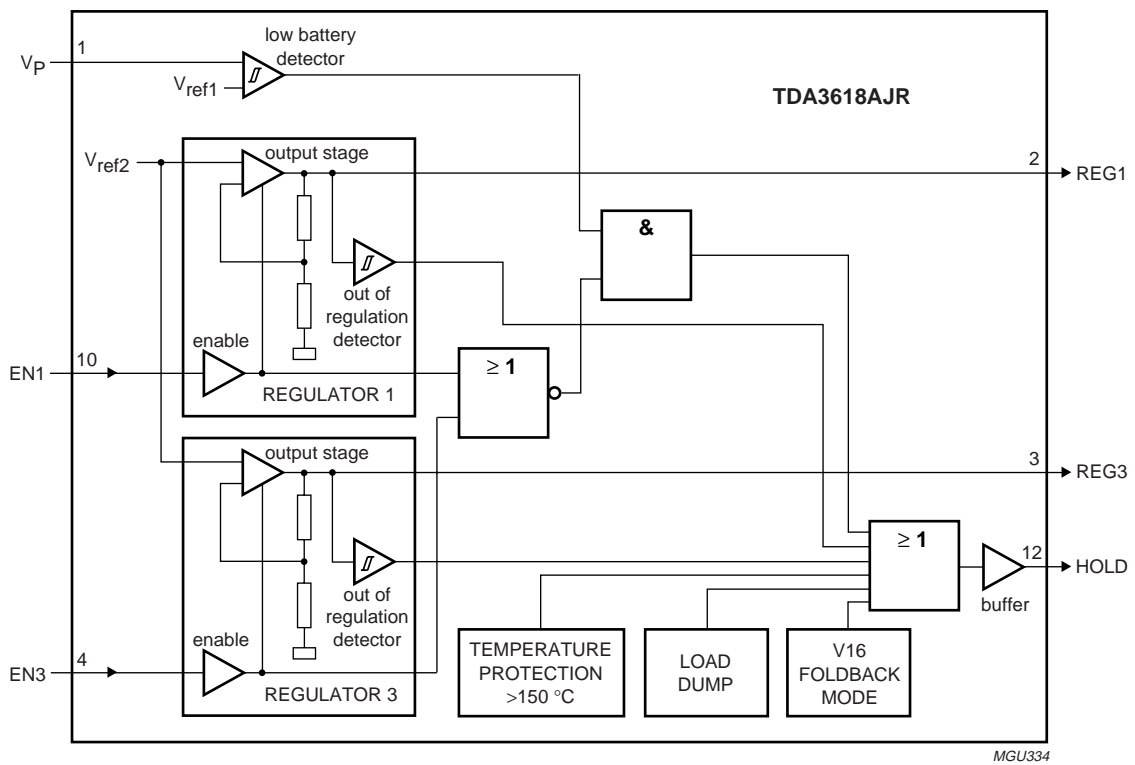

Fig.3 Block diagram of the hold circuit.

Multiple voltage regulator with switch and ignition buffers

TDA3618AJR

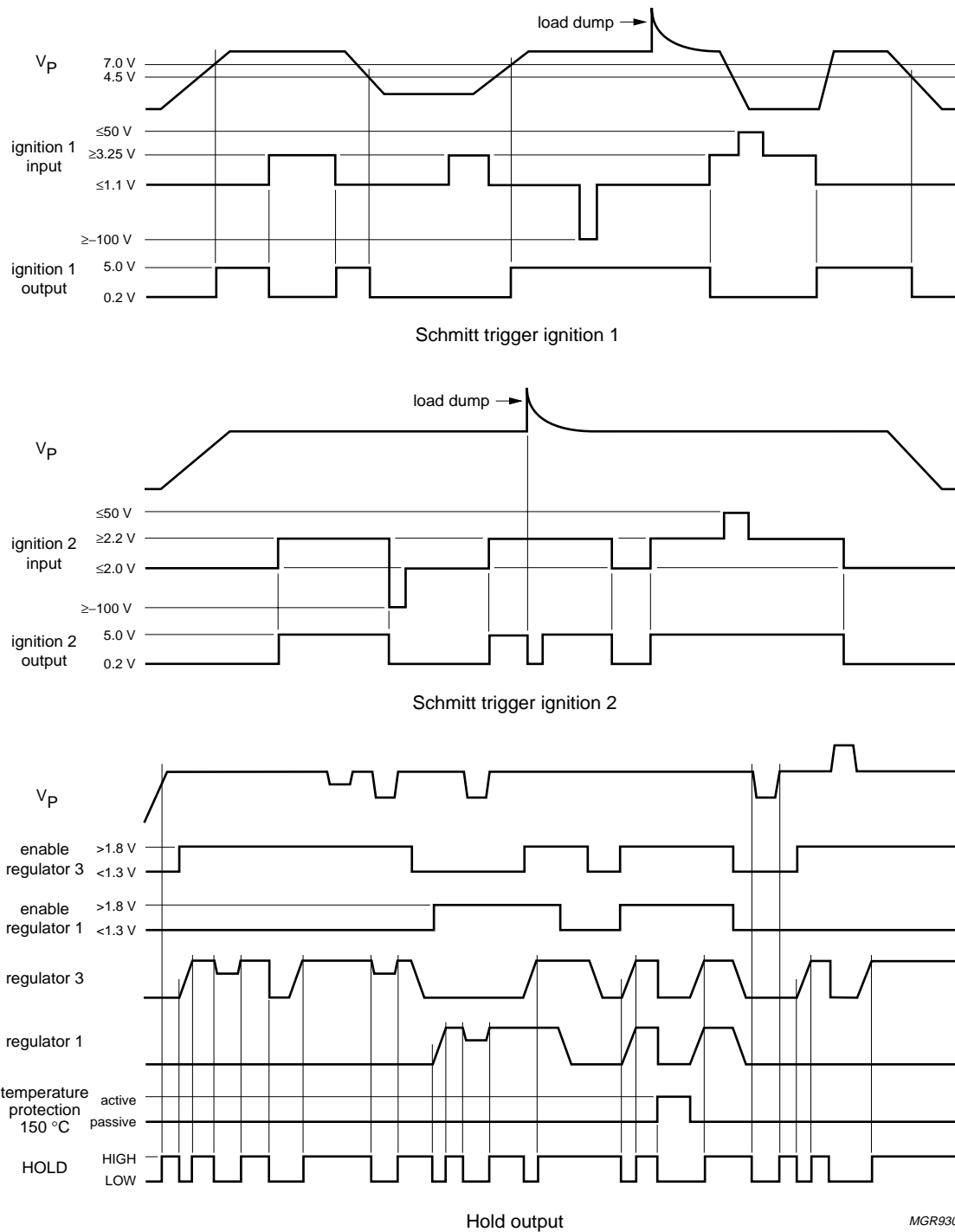
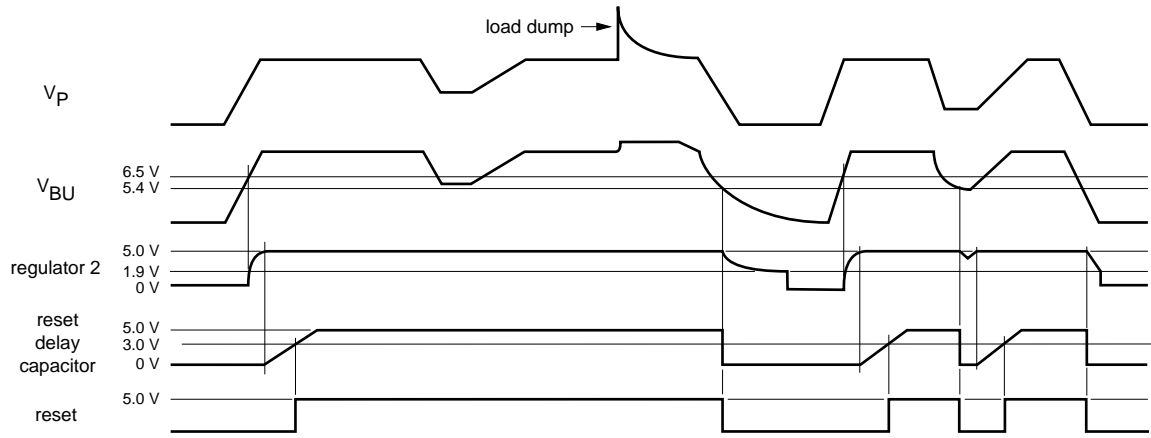

Fig.4 Timing diagram of ignition Schmitt triggers and HOLD.

MGR930

Multiple voltage regulator with switch and ignition buffers

TDA3618AJR



Backup Schmitt trigger and reset behaviour

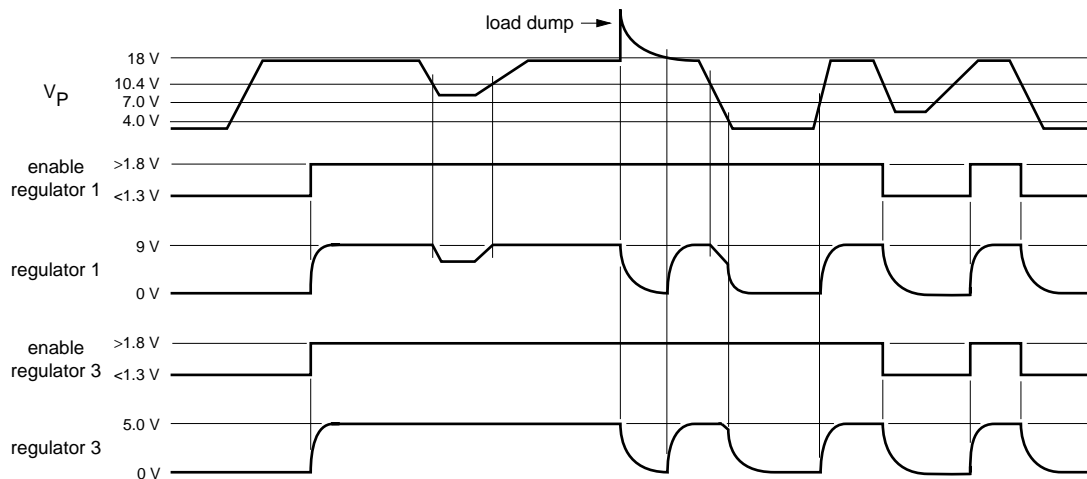

V_P and enable Schmitt trigger

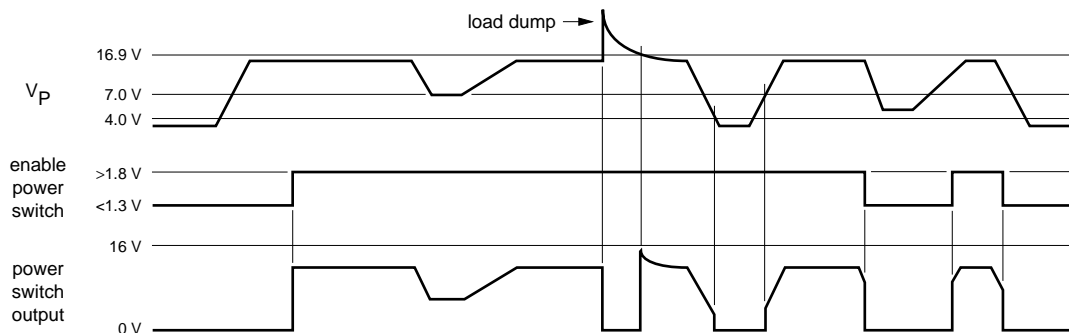

Power switch behaviour

MGK610

Fig.5 Timing diagram of regulators and power switch.

Multiple voltage regulator with switch and ignition buffers

TDA3618AJR

LIMITING VALUES

In accordance with the Absolute Maximum Rating System (IEC 60134).

| SYMBOL | PARAMETER | CONDITIONS | MIN. | MAX. | UNIT |
|------------------|-------------------------|--|------|------|------|
| V _P | supply voltage | operating | – | 18 | V |
| | | reverse polarity; non-operating | – | –18 | V |
| | | jump start; t ≤ 10 minutes | – | 30 | V |
| | | load dump protection; t ≤ 50 ms; t _r ≥ 2.5 ms | – | 50 | V |
| P _{tot} | total power dissipation | | – | 62 | W |
| T _{stg} | storage temperature | non-operating | –55 | +150 | °C |
| T _{amb} | ambient temperature | operating | –40 | +85 | °C |
| T _j | junction temperature | operating | –40 | +150 | °C |

THERMAL CHARACTERISTICS

| SYMBOL | PARAMETER | CONDITIONS | VALUE | UNIT |
|----------------------|---|-------------|-------|------|
| R _{th(j-c)} | thermal resistance from junction to case | | 2 | K/W |
| R _{th(j-a)} | thermal resistance from junction to ambient | in free air | 50 | K/W |

Multiple voltage regulator with switch and ignition buffers

TDA3618AJR

CHARACTERISTICS $V_P = 14.4\text{ V}$; $T_{\text{amb}} = 25\text{ °C}$; see Fig.8; unless otherwise specified.

| SYMBOL | PARAMETER | CONDITIONS | MIN. | TYP. | MAX. | UNIT |
|--|---|---|------|-----------------------------|------------------------------|---------------|
| Supplies | | | | | | |
| V_P | supply voltage | operating | 11 | 14.4 | 18 | V |
| | | regulator 2 on; note 1 | 2.4 | 14.4 | 18 | V |
| | | jump start; $t \leq 10$ minutes | – | – | 30 | V |
| | | load dump protection; $t \leq 50\text{ ms}$; $t_r \geq 2.5\text{ ms}$ | – | – | 50 | V |
| I_q | quiescent supply current | $V_P = 12.4\text{ V}$; note 2 | – | 390 | 500 | μA |
| | | $V_P = 14.4\text{ V}$; note 2 | – | 400 | – | μA |
| Schmitt trigger for regulator 1, regulator 3 and the power switch | | | | | | |
| $V_{\text{th}(r)}$ | rising threshold voltage | | 6.5 | 7.0 | 7.5 | V |
| $V_{\text{th}(f)}$ | falling threshold voltage | | 4.0 | 4.5 | 5.0 | V |
| V_{hys} | hysteresis voltage | | – | 2.5 | – | V |
| Schmitt trigger for regulator 2 | | | | | | |
| $V_{\text{th}(r)}$ | rising threshold voltage | | 6.0 | 6.5 | 7.1 | V |
| $V_{\text{th}(f)}$ | falling threshold voltage | | 1.7 | 1.9 | 2.3 | V |
| V_{hys} | hysteresis voltage | | – | 4.6 | – | V |
| Schmitt trigger for enable inputs (regulator 1, regulator 3 and the power switch) | | | | | | |
| $V_{\text{th}(r)}$ | rising threshold voltage | | 1.4 | 1.8 | 2.4 | V |
| $V_{\text{th}(f)}$ | falling threshold voltage | | 0.9 | 1.3 | 1.9 | V |
| V_{hys} | hysteresis voltage | $I_{\text{REG}} = I_{\text{SW}} = 1\text{ mA}$ | – | 0.5 | – | V |
| I_{LI} | input leakage current | $V_{\text{EN}} = 5\text{ V}$ | 1 | 5 | 10 | μA |
| Reset trigger level of regulator 2 | | | | | | |
| $V_{\text{th}(r)}$ | rising threshold voltage | V_P rising; $I_{\text{REG}1} = 50\text{ mA}$; note 3 | 4.43 | $V_{\text{O(REG}2)} - 0.15$ | $V_{\text{O(REG}2)} - 0.1$ | V |
| $V_{\text{th}(f)}$ | falling threshold voltage | V_P falling; $I_{\text{REG}1} = 50\text{ mA}$; note 3 | 4.4 | $V_{\text{O(REG}2)} - 0.20$ | $V_{\text{O(REG}2)} - 0.15$ | V |
| Schmitt triggers for HOLD output | | | | | | |
| $V_{\text{th}(r)(\text{REG}1)}$ | rising threshold voltage of regulator 1 | V_P rising; note 3 | – | $V_{\text{O(REG}1)} - 0.15$ | $V_{\text{O(REG}1)} - 0.075$ | V |
| $V_{\text{th}(f)(\text{REG}1)}$ | falling threshold voltage of regulator 1 | V_P falling; note 3 | 8.1 | $V_{\text{O(REG}1)} - 0.35$ | – | V |
| $V_{\text{hys}(\text{REG}1)}$ | hysteresis voltage due to regulator 1 | | – | 0.2 | – | V |
| $V_{\text{th}(r)(\text{REG}3)}$ | rising threshold voltage of regulator 3 | V_P rising; note 3 | – | $V_{\text{O(REG}3)} - 0.15$ | $V_{\text{O(REG}3)} - 0.075$ | V |
| $V_{\text{th}(f)(\text{REG}3)}$ | falling threshold voltage of regulator 3 | V_P falling; note 3 | 4.1 | $V_{\text{O(REG}3)} - 0.35$ | – | V |
| $V_{\text{hys}(\text{REG}3)}$ | hysteresis voltage due to regulator 3 | | – | 0.2 | – | V |

Multiple voltage regulator with switch and ignition buffers

TDA3618AJR

| SYMBOL | PARAMETER | CONDITIONS | MIN. | TYP. | MAX. | UNIT |
|---|---|--|------|---------------|------|---------------|
| $V_{th(r)(VP)}$ | rising threshold voltage of supply voltage | $V_{EN} = 0\text{ V}$ | 9.1 | 9.7 | 10.3 | V |
| $V_{th(f)(VP)}$ | falling threshold voltage of supply voltage | $V_{EN} = 0\text{ V}$ | 9.0 | 9.4 | 9.8 | V |
| $V_{hys(VP)}$ | hysteresis voltage of supply voltage | $V_{EN} = 0\text{ V}$ | – | 0.3 | – | V |
| Reset and hold buffer | | | | | | |
| $I_{sink(L)}$ | LOW-level sink current | $V_{RES} \leq 0.8\text{ V};$ $V_{HOLD} \leq 0.8\text{ V};$ $V_{CRES} < 1.0\text{ V}$ | 2 | – | – | mA |
| I_{LO} | HOLD output leakage current | $V_P = 14.4\text{ V}; V_{HOLD} = 5\text{ V}$ | – | 0.1 | 5 | μA |
| $I_{source(H)}$ | HIGH-level source current | $V_P = 14.4\text{ V}; V_{RES} = 4.5\text{ V};$ $V_{CRES} > 3.5\text{ V}$ | 240 | 400 | 900 | μA |
| t_r | rise time | note 4 | – | 7 | 50 | μs |
| t_f | fall time | note 4 | – | 1 | 50 | μs |
| Reset delay | | | | | | |
| I_{ch} | charge current | | 2 | 4 | 8 | μA |
| I_{dch} | discharge current | | 500 | 800 | – | μA |
| $V_{th(r)(RES)}$ | rising voltage threshold reset signal | | 2.5 | 3.0 | 3.5 | V |
| $t_{d(RES)}$ | delay time reset signal | $C = 47\text{ nF};$ note 5 | 20 | 35 | 70 | ms |
| $V_{th(r)(SW)}$ | rising voltage threshold switch foldback protection | | – | $V_{O(REG2)}$ | – | V |
| $t_{d(SW)}$ | delay time switch foldback protection | $C = 47\text{ nF};$ note 6 | 8 | 17.6 | 40 | ms |
| Regulator 1 ($I_{REG1} = 5\text{ mA}$ unless otherwise specified) | | | | | | |
| $V_{O(off)}$ | output voltage off | | – | 1 | 400 | mV |
| $V_{O(REG1)}$ | output voltage | $1\text{ mA} \leq I_{REG1} \leq 600\text{ mA}$ | 8.5 | 9.0 | 9.5 | V |
| | | $12\text{ V} \leq V_P \leq 18\text{ V}$ | 8.5 | 9.0 | 9.5 | V |
| ΔV_{line} | line regulation | $12\text{ V} \leq V_P \leq 18\text{ V}$ | – | 2 | 75 | mV |
| ΔV_{load} | load regulation | $1\text{ mA} \leq I_{REG1} \leq 600\text{ mA}$ | – | 20 | 100 | mV |
| I_q | quiescent current | $I_{REG1} = 600\text{ mA}$ | – | 25 | 60 | mA |
| SVRR | supply voltage ripple rejection | $f_i = 3\text{ kHz}; V_{i(p-p)} = 2\text{ V}$ | 60 | 70 | – | dB |
| V_{drop} | drop-out voltage | $I_{REG1} = 550\text{ mA};$ $V_P = 9.5\text{ V};$ note 7 | – | 0.4 | 0.7 | V |
| I_{lim} | current limit | $V_{O(REG1)} > 8.5\text{ V};$ note 8 | 0.65 | 1.2 | – | A |
| I_{sc} | short-circuit current | $R_L \leq 0.5\ \Omega;$ note 9 | 250 | 800 | – | mA |

Multiple voltage regulator with
switch and ignition buffers

TDA3618AJR

| SYMBOL | PARAMETER | CONDITIONS | MIN. | TYP. | MAX. | UNIT |
|--|---------------------------------|--|------|------|------|------|
| Regulator 2 ($I_{REG2} = 5 \text{ mA}$ unless otherwise specified) | | | | | | |
| $V_{O(REG2)}$ | output voltage | $0.5 \text{ mA} \leq I_{REG2} \leq 300 \text{ mA}$ | 4.75 | 5.0 | 5.25 | V |
| | | $8 \text{ V} \leq V_P \leq 18 \text{ V}$ | 4.75 | 5.0 | 5.25 | V |
| | | $18 \text{ V} \leq V_P \leq 50 \text{ V};$ $I_{REG2} \leq 150 \text{ mA}$ | 4.75 | 5.0 | 5.25 | V |
| ΔV_{line} | line regulation | $6 \text{ V} \leq V_P \leq 18 \text{ V}$ | – | 2 | 50 | mV |
| | | $6 \text{ V} \leq V_P \leq 50 \text{ V}$ | – | 15 | 75 | mV |
| ΔV_{load} | load regulation | $1 \text{ mA} \leq I_{REG2} \leq 150 \text{ mA}$ | – | 20 | 50 | mV |
| | | $1 \text{ mA} \leq I_{REG2} \leq 300 \text{ mA}$ | – | – | 100 | mV |
| SVRR | supply voltage ripple rejection | $f_i = 3 \text{ kHz}; V_{i(p-p)} = 2 \text{ V}$ | 60 | 70 | – | dB |
| V_{drop} | drop-out voltage | $I_{REG2} = 100 \text{ mA};$ $V_P = 4.75 \text{ V};$ note 7 | – | 0.4 | 0.6 | V |
| | | $I_{REG2} = 200 \text{ mA};$ $V_P = 5.75 \text{ V};$ note 7 | – | 0.8 | 1.2 | V |
| | | $I_{REG2} = 100 \text{ mA};$ $V_{BU} = 4.75 \text{ V};$ note 10 | – | 0.2 | 0.5 | V |
| | | $I_{REG2} = 200 \text{ mA};$ $V_{BU} = 5.75 \text{ V};$ note 10 | – | 0.8 | 1.0 | V |
| I_{lim} | current limit | $V_{O(REG2)} > 4.5 \text{ V};$ note 8 | 0.32 | 0.37 | – | A |
| I_{sc} | short-circuit current | $R_L \leq 0.5 \Omega;$ note 9 | 20 | 100 | – | mA |
| Regulator 3 ($I_{REG3} = 5 \text{ mA}$ unless otherwise specified) | | | | | | |
| $V_{O(off)}$ | output voltage off | | – | 1 | 400 | mV |
| $V_{O(REG3)}$ | output voltage | $1 \text{ mA} \leq I_{REG3} \leq 750 \text{ mA}$ | 4.75 | 5.0 | 5.25 | V |
| | | $7 \text{ V} \leq V_P \leq 18 \text{ V}$ | 4.75 | 5.0 | 5.25 | V |
| ΔV_{line} | line regulation | $7 \text{ V} \leq V_P \leq 18 \text{ V}$ | – | 2 | 50 | mV |
| ΔV_{load} | load regulation | $1 \text{ mA} \leq I_{REG3} \leq 750 \text{ mA}$ | – | 20 | 100 | mV |
| I_q | quiescent current | $I_{REG3} = 750 \text{ mA}$ | – | 19 | 45 | mA |
| SVRR | supply voltage ripple rejection | $f_i = 3 \text{ kHz}; V_{i(p-p)} = 2 \text{ V}$ | 60 | 70 | – | dB |
| V_{drop} | drop-out voltage | $I_{REG3} = 500 \text{ mA};$ $V_P = 5.75 \text{ V};$ note 7 | – | 1 | 1.5 | V |
| I_{lim} | current limit | $V_{O(REG3)} > 4.5 \text{ V};$ note 8 | 0.80 | 0.90 | – | A |
| I_{sc} | short-circuit current | $R_L \leq 0.5 \Omega;$ note 9 | 100 | 400 | – | mA |
| Power switch | | | | | | |
| V_{drop} | drop-out voltage | $I_{SW} = 1 \text{ A}; V_P = 13.5 \text{ V};$ note 11 | – | 0.45 | 0.70 | V |
| | | $I_{SW} = 1.8 \text{ A}; V_P = 13.5 \text{ V};$ note 11 | – | 1.0 | 1.8 | V |
| I_{dc} | continuous current | $V_P = 16 \text{ V}; V_{SW} = 13.5 \text{ V}$ | 1.8 | 2.0 | – | A |
| V_{clamp} | clamping voltage | $V_P \geq 17 \text{ V}$ | 13.5 | 15.0 | 16.0 | V |

Multiple voltage regulator with switch and ignition buffers

TDA3618AJR

| SYMBOL | PARAMETER | CONDITIONS | MIN. | TYP. | MAX. | UNIT |
|---|---|--|-------|-----------|------|---------------|
| I_M | peak current | $V_P = 17\text{ V}$; notes 6, 12, 13 | 3 | – | – | A |
| V_{fb} | flyback voltage behaviour | $I_{SW} = -100\text{ mA}$ | – | $V_P + 3$ | 22 | V |
| I_{sc} | short-circuit current | $V_P = 14.4\text{ V}$; $V_{SW} < 1.2\text{ V}$; note 13 | – | 0.8 | – | A |
| Backup switch | | | | | | |
| I_{dc} | continuous current | | 0.3 | 0.35 | – | A |
| V_{clamp} | clamping voltage | $V_P \geq 16.7\text{ V}$ | – | – | 16 | V |
| I_r | reverse current | $V_P = 0\text{ V}$; $V_{BU} = 12.4\text{ V}$ | – | – | –900 | μA |
| Schmitt trigger for enable input of ignition 1 | | | | | | |
| $V_{th(r)}$ | rising threshold voltage of ignition 1 input | | 2.75 | 3.25 | 3.75 | V |
| $V_{th(f)}$ | falling threshold voltage of ignition 1 input | | 0.8 | – | 1.3 | V |
| V_{hys} | hysteresis voltage | | 1.5 | – | – | V |
| I_{LI} | input leakage current | $V_{IGN1IN} = 5\text{ V}$ | – | – | 1.0 | μA |
| $I_{I(clamp)}$ | input clamping current | $V_{IGN1IN} > 50\text{ V}$ | – | – | 50 | mA |
| $V_{IH(clamp)}$ | HIGH-level input clamping voltage | | V_P | – | 50 | V |
| $V_{IL(clamp)}$ | LOW-level input clamping voltage | | –0.6 | – | 0 | V |
| Schmitt trigger for power supply of ignition 1 | | | | | | |
| $V_{th(r)}$ | rising threshold voltage | | 6.5 | 7.0 | 7.5 | V |
| $V_{th(f)}$ | falling threshold voltage | note 14 | 4.0 | 4.5 | 5.0 | V |
| Ignition 1 buffer | | | | | | |
| V_{OL} | LOW-level output voltage | $I_{IGN1OUT} = 0\text{ mA}$ | 0 | 0.2 | 0.8 | V |
| V_{OH} | HIGH-level output voltage | $I_{IGN1OUT} = 0\text{ mA}$ | 4.5 | 5.0 | 5.25 | V |
| I_{OL} | LOW-level output current | $V_{IGN1OUT} \leq 0.8\text{ V}$ | 0.45 | 0.8 | – | mA |
| I_{LO} | output leakage current | $V_{IGN1OUT} = 5\text{ V}$; $V_{IGN1IN} = 0\text{ V}$ | – | – | 1.0 | μA |
| t_{PLH} | LOW-to-HIGH propagation time | V_{IGN1IN} falling from 3.75 to 0.8 V | – | – | 500 | μs |
| t_{PHL} | HIGH-to-LOW propagation time | V_{IGN1IN} rising from 0.8 to 3.75 V | – | – | 500 | μs |
| Schmitt trigger for enable input of ignition 2 | | | | | | |
| $V_{th(r)}$ | rising threshold voltage of ignition 2 input | $V_P > 3.5\text{ V}$ | 1.9 | 2.2 | 2.5 | V |
| $V_{th(f)}$ | falling threshold voltage of ignition 2 input | $V_P > 3.5\text{ V}$ | 1.7 | 2.0 | 2.3 | V |
| V_{hys} | hysteresis voltage | $V_P > 3.5\text{ V}$ | 0.1 | 0.2 | 0.5 | V |
| I_{LI} | input leakage current | $V_{IGN2IN} = 5\text{ V}$ | – | – | 1.0 | μA |
| $I_{I(clamp)}$ | input clamp current | $V_{IGN2IN} > 50\text{ V}$ | – | – | 50 | mA |

Multiple voltage regulator with switch and ignition buffers

TDA3618AJR

| SYMBOL | PARAMETER | CONDITIONS | MIN. | TYP. | MAX. | UNIT |
|--------------------------|-----------------------------------|--|-------|------|------|---------------|
| $V_{IH(\text{clamp})}$ | HIGH-level input clamping voltage | | V_P | – | 50 | V |
| $V_{IL(\text{clamp})}$ | LOW-level input clamping voltage | | –0.6 | – | 0 | V |
| Ignition 2 buffer | | | | | | |
| V_{OL} | LOW-level output voltage | $I_{IGN2OUT} = 0 \text{ mA}$ | 0 | 0.2 | 0.8 | V |
| V_{OH} | HIGH-level output voltage | $I_{IGN2OUT} = 0 \text{ mA}$ | 4.5 | 5.0 | 5.25 | V |
| I_{OL} | LOW-level output current | $V_{IGN2OUT} \leq 0.8 \text{ V}$ | 0.45 | 0.8 | – | mA |
| I_{OH} | HIGH-level output current | $V_{IGN2OUT} \geq 4.5 \text{ V}$ | –0.45 | –2.0 | – | mA |
| I_{LO} | output leakage current (source) | $V_{IGN2OUT} = 5 \text{ V};$ $V_{IGN2IN} = 5 \text{ V}$ | – | – | 1.0 | μA |
| t_{PLH} | LOW-to-HIGH propagation time | V_{IGN2IN} rising from 1.7 to 2.5 V | – | – | 500 | μs |
| t_{PHL} | HIGH-to-LOW propagation time | V_{IGN2IN} falling from 2.5 to 1.7 V | – | – | 500 | μs |

Notes

- Minimum operating voltage, only if V_P has exceeded 6.5 V.
- The quiescent current is measured in the standby mode with pins EN1, EN2 and ENSW connected to ground and $R_{L(\text{REG2})} = \infty$ (see Fig.8).
- The voltage of the regulator drops as a result of a V_P drop.
- The rise and fall times are measured with a 10 k Ω pull-up resistor and a 50 pF load capacitor.
- The delay time depends on the value of the capacitor connected to pin C_{RES} :

$$t_{d(\text{RES})} = \frac{C}{I_{ch}} \times V_{th(r)(\text{RES})} = C \times (750 \times 10^3) \text{ [s]}$$
- The delay time depends on the value of the capacitor connected to pin C_{RES} :

$$t_{d(\text{RES})} = \frac{C}{I_{ch}} \times (V_{O(\text{REG2})} - 3.5) = C \times (375 \times 10^3) \text{ [s]}$$
- The drop-out voltage of regulators 1, 2 and 3 is measured between pins V_P and REGn .
- At current limit, I_{lim} is held constant (see Fig.6 for the behaviour of I_{lim}).
- The foldback current protection limits the dissipated power at short-circuit (see Fig.6).
- The drop-out voltage is measured between pins BU and REG2.
- The drop-out voltage of the power switch is measured between pins V_P and SW.
- The maximum output current of the switch is limited to 1.8 A when the supply voltage exceeds 18 V. A test mode is built in. The delay time of the switch is disabled when a voltage of $V_P + 1 \text{ V}$ is applied to the switch-enable input.
- At short-circuit, I_{sc} of the power switch is held constant to a lower value than the continuous current after a delay of at least 10 ms. A test-mode is built in. The delay time of the switch is disabled when a voltage of $V_P + 1 \text{ V}$ is applied to the switch-enable input.
- $V_{IGN1OUT} = \text{LOW}$ for $V_{IGN1IN} > 1.2 \text{ V}$ or $V_{EN1} > 1.3 \text{ V}$ or $V_{EN3} > 1.3 \text{ V}$ or $V_{ENSW} > 1.3 \text{ V}$.

Multiple voltage regulator with switch and ignition buffers

TDA3618AJR

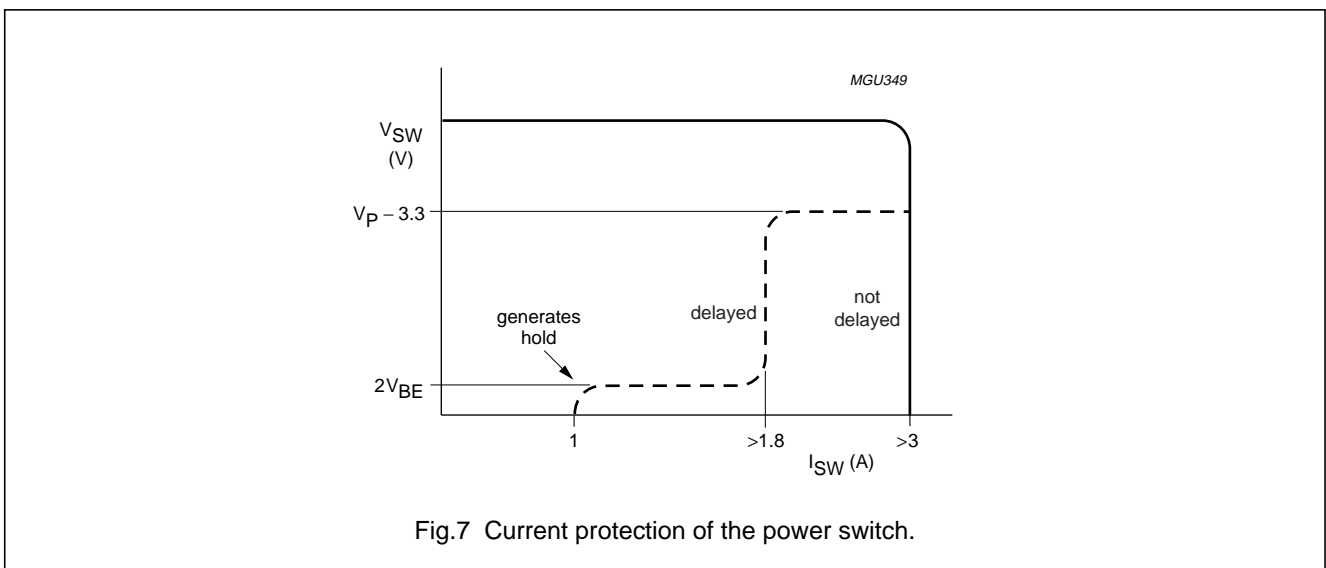
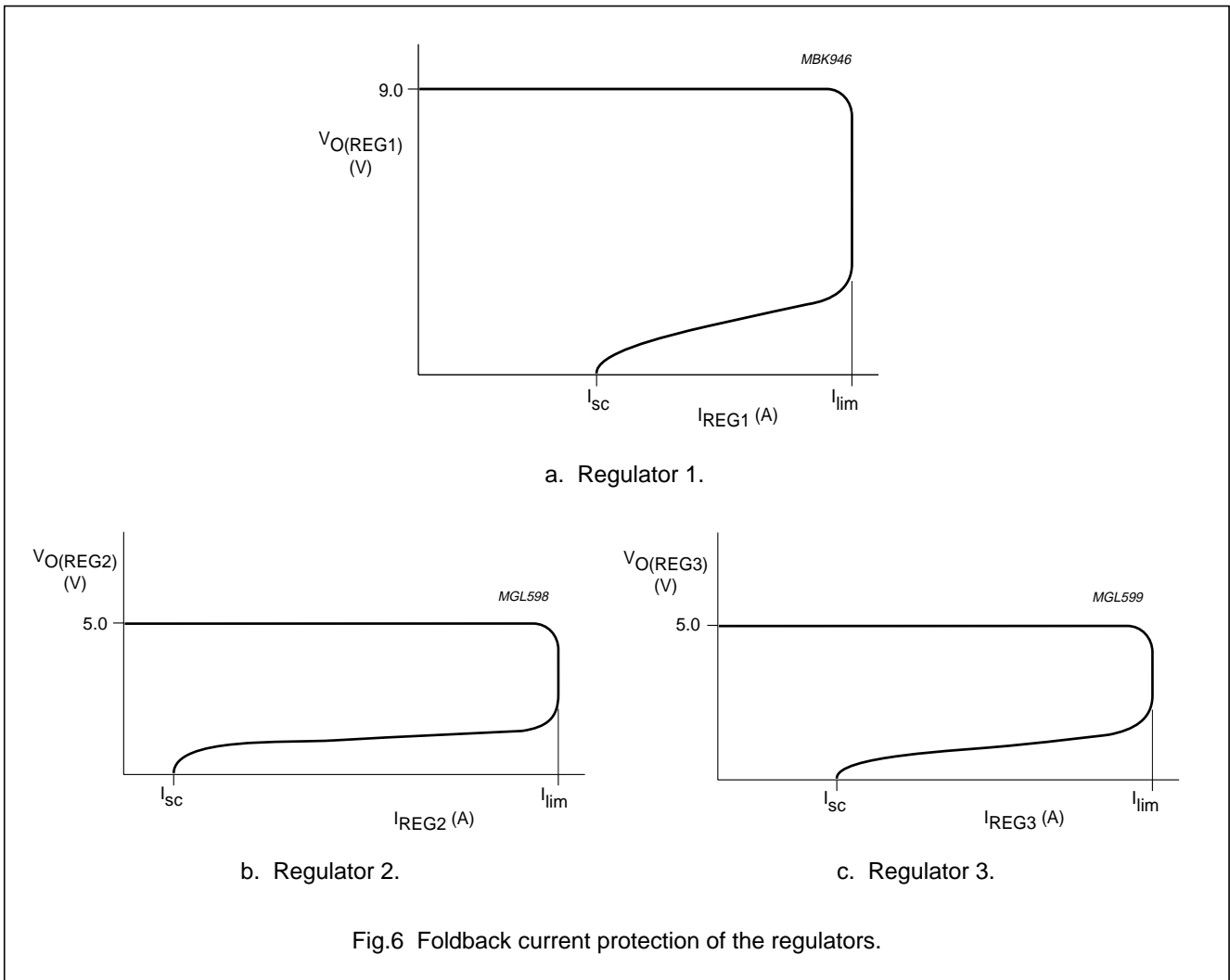

Multiple voltage regulator with switch and ignition buffers

TDA3618AJR

TEST AND APPLICATION INFORMATION

Test information

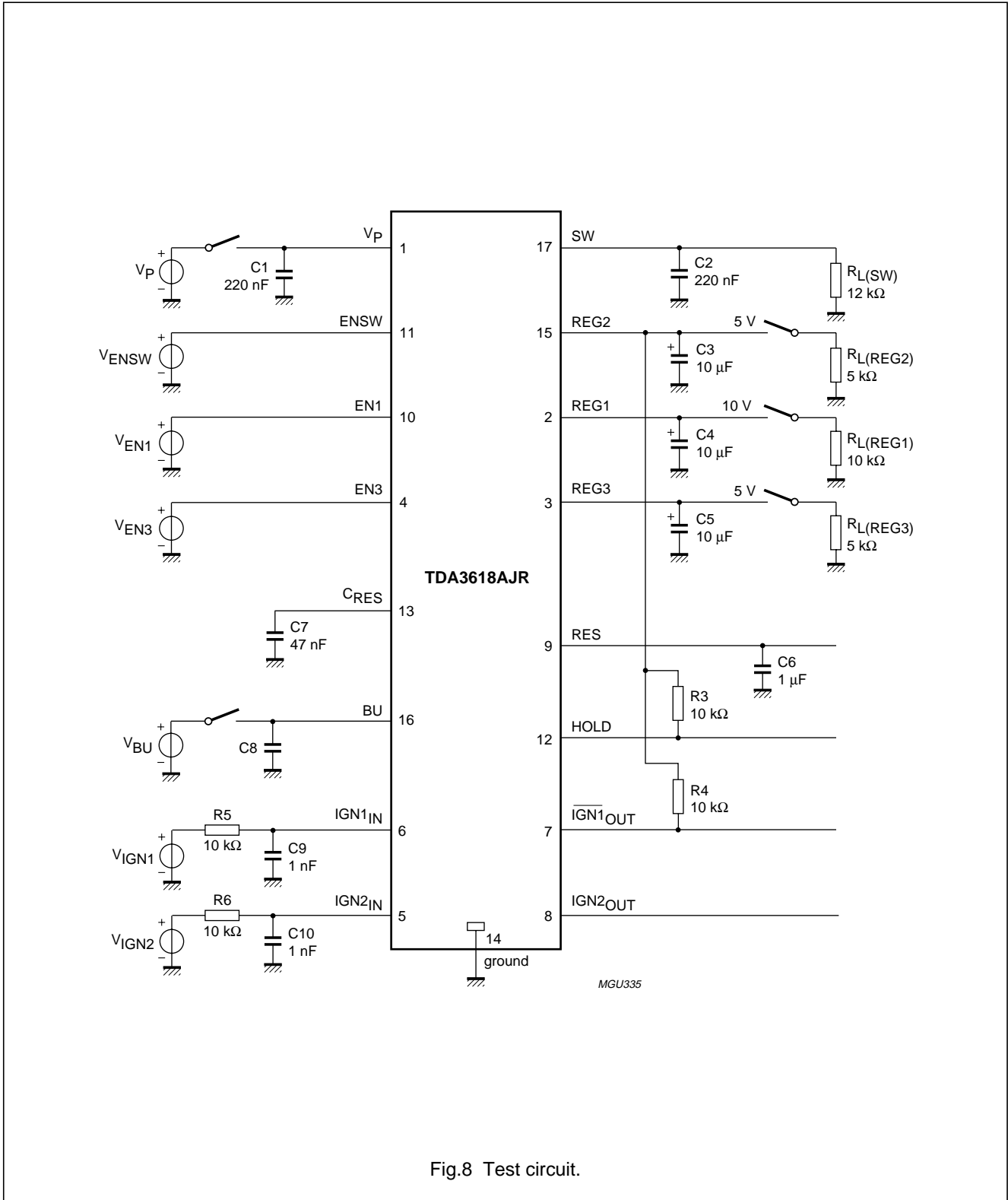

Fig.8 Test circuit.

Multiple voltage regulator with switch and ignition buffers

TDA3618AJR

Application information

NOISE

Table 1 Noise figures

| REGULATOR | NOISE FIGURE (μV) ⁽¹⁾ | | |
|-----------|---|------------------|-------------------|
| | $C_o = 10 \mu F$ | $C_o = 47 \mu F$ | $C_o = 100 \mu F$ |
| 1 | 170 | 130 | 110 |
| 2 | 180 | 120 | 100 |
| 3 | 100 | 70 | 65 |

Note

1. Measured at a bandwidth of 200 kHz.

The noise on the supply line depends on the value of the supply capacitor and is caused by a current noise (the output noise of the regulators is translated to a current noise by the output capacitors). When a high frequency capacitor of 220 nF in parallel with an electrolytic capacitor of 100 μF is connected directly to pins 1 and 14 (supply and ground), the noise is minimal.

STABILITY

The regulators are stabilized with the externally connected output capacitors.

The output capacitors can be selected by using the graphs of Figs 9 and 10. When an electrolytic capacitor is used, the temperature behaviour of this output capacitor can cause oscillations at a low temperature. The two examples below show how an output capacitor value is selected.

Example 1

Regulators 1 and 3 are stabilized with an electrolytic output capacitor of 220 μF (ESR = 0.15 Ω). At $T_{amb} = -30 \text{ }^\circ C$, the capacitor value is decreased to 73 μF and the ESR is increased to 1.1 Ω . The regulator remains stable at $T_{amb} = -30 \text{ }^\circ C$.

Example 2

Regulator 2 is stabilized with a 10 μF electrolytic capacitor (ESR = 3 Ω). At $T_{amb} = -30 \text{ }^\circ C$, the capacitor value is decreased to 3 μF and the ESR is increased to 23.1 Ω . Using Fig.10, the regulator will be unstable at $T_{amb} = -30 \text{ }^\circ C$.

Solution

To avoid problems with stability at low temperatures, the use of tantalum capacitors is recommended. Use a tantalum capacitor of 10 μF or a larger electrolytic capacitor.

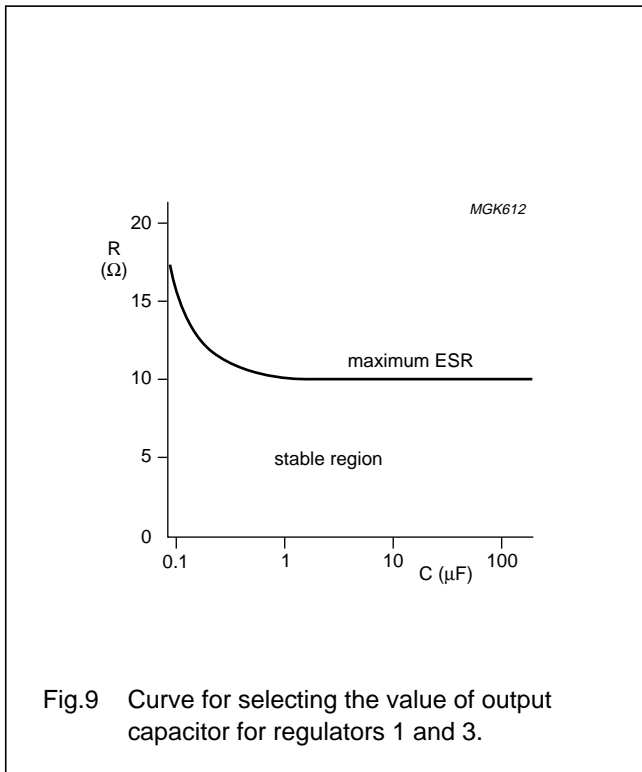

Fig.9 Curve for selecting the value of output capacitor for regulators 1 and 3.

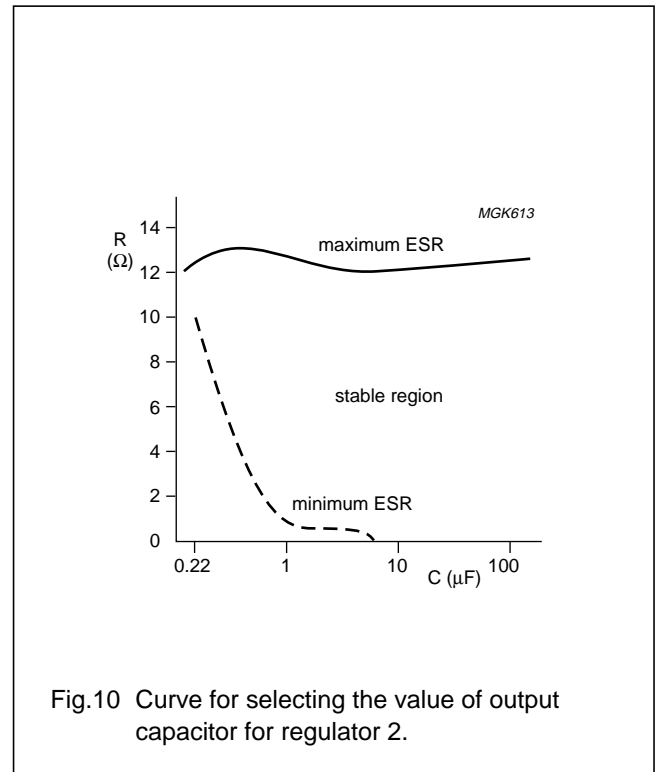

Fig.10 Curve for selecting the value of output capacitor for regulator 2.

Multiple voltage regulator with switch and ignition buffers

TDA3618AJR

PACKAGE OUTLINE

DBS17P: plastic DIL-bent-SIL (special bent) power package; 17 leads (lead length 12 mm)

SOT475-1

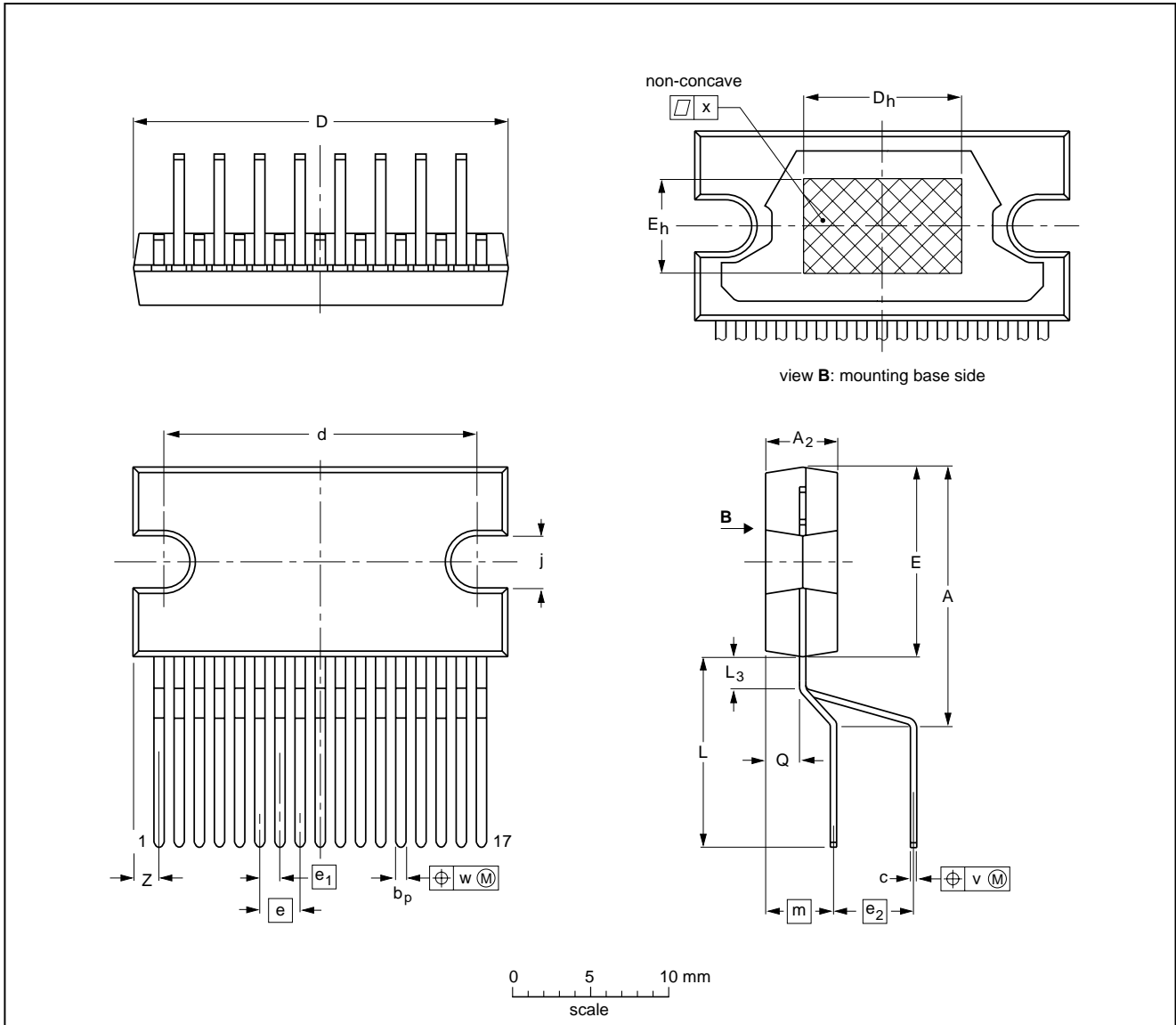

DIMENSIONS (mm are the original dimensions)

| UNIT | A | A ₂ | b _p | c | D ⁽¹⁾ | d | D _h | E ⁽¹⁾ | e | e ₁ | e ₂ | E _h | j | L | L ₃ | m | Q | v | w | x | z ⁽¹⁾ |
|------|--------------|----------------|----------------|--------------|------------------|--------------|----------------|------------------|------|----------------|----------------|----------------|------------|--------------|----------------|-----|------------|-----|-----|------|------------------|
| mm | 17.0 15.5 | 4.6 4.4 | 0.75 0.60 | 0.48 0.38 | 24.0 23.6 | 20.0 19.6 | 10 | 12.2 11.8 | 2.54 | 1.27 | 5.08 | 6 | 3.4 3.1 | 12.4 11.0 | 2.4 1.6 | 4.3 | 2.1 1.8 | 0.8 | 0.4 | 0.03 | 2.00 1.45 |

Note

1. Plastic or metal protrusions of 0.25 mm maximum per side are not included.

| OUTLINE VERSION | REFERENCES | | | | EUROPEAN PROJECTION | ISSUE DATE |
|-----------------|------------|-------|------|--|---------------------|----------------------|
| | IEC | JEDEC | EIAJ | | | |
| SOT475-1 | | | | | | 97-05-20 99-12-17 |

Multiple voltage regulator with switch and ignition buffers

TDA3618AJR

SOLDERING

Introduction to soldering through-hole mount packages

This text gives a brief insight to wave, dip and manual soldering. A more in-depth account of soldering ICs can be found in our *“Data Handbook IC26; Integrated Circuit Packages”* (document order number 9398 652 90011).

Wave soldering is the preferred method for mounting of through-hole mount IC packages on a printed-circuit board.

Soldering by dipping or by solder wave

The maximum permissible temperature of the solder is 260 °C; solder at this temperature must not be in contact with the joints for more than 5 seconds.

The total contact time of successive solder waves must not exceed 5 seconds.

The device may be mounted up to the seating plane, but the temperature of the plastic body must not exceed the specified maximum storage temperature ($T_{stg(max)}$). If the printed-circuit board has been pre-heated, forced cooling may be necessary immediately after soldering to keep the temperature within the permissible limit.

Manual soldering

Apply the soldering iron (24 V or less) to the lead(s) of the package, either below the seating plane or not more than 2 mm above it. If the temperature of the soldering iron bit is less than 300 °C it may remain in contact for up to 10 seconds. If the bit temperature is between 300 and 400 °C, contact may be up to 5 seconds.

Suitability of through-hole mount IC packages for dipping and wave soldering methods

| PACKAGE | SOLDERING METHOD | |
|---------------------------|------------------|-------------------------|
| | DIPPING | WAVE |
| DBS, DIP, HDIP, SDIP, SIL | suitable | suitable ⁽¹⁾ |

Note

- For SDIP packages, the longitudinal axis must be parallel to the transport direction of the printed-circuit board.

Multiple voltage regulator with switch and ignition buffers

TDA3618AJR

DATA SHEET STATUS

| DATA SHEET STATUS ⁽¹⁾ | PRODUCT STATUS ⁽²⁾ | DEFINITIONS |
|----------------------------------|-------------------------------|--|
| Objective data | Development | This data sheet contains data from the objective specification for product development. Philips Semiconductors reserves the right to change the specification in any manner without notice. |
| Preliminary data | Qualification | This data sheet contains data from the preliminary specification. Supplementary data will be published at a later date. Philips Semiconductors reserves the right to change the specification without notice, in order to improve the design and supply the best possible product. |
| Product data | Production | This data sheet contains data from the product specification. Philips Semiconductors reserves the right to make changes at any time in order to improve the design, manufacturing and supply. Changes will be communicated according to the Customer Product/Process Change Notification (CPCN) procedure SNW-SQ-650A. |

Notes

1. Please consult the most recently issued data sheet before initiating or completing a design.
2. The product status of the device(s) described in this data sheet may have changed since this data sheet was published. The latest information is available on the Internet at URL <http://www.semiconductors.philips.com>.

DEFINITIONS

Short-form specification — The data in a short-form specification is extracted from a full data sheet with the same type number and title. For detailed information see the relevant data sheet or data handbook.

Limiting values definition — Limiting values given are in accordance with the Absolute Maximum Rating System (IEC 60134). Stress above one or more of the limiting values may cause permanent damage to the device. These are stress ratings only and operation of the device at these or at any other conditions above those given in the Characteristics sections of the specification is not implied. Exposure to limiting values for extended periods may affect device reliability.

Application information — Applications that are described herein for any of these products are for illustrative purposes only. Philips Semiconductors make no representation or warranty that such applications will be suitable for the specified use without further testing or modification.

DISCLAIMERS

Life support applications — These products are not designed for use in life support appliances, devices, or systems where malfunction of these products can reasonably be expected to result in personal injury. Philips Semiconductors customers using or selling these products for use in such applications do so at their own risk and agree to fully indemnify Philips Semiconductors for any damages resulting from such application.

Right to make changes — Philips Semiconductors reserves the right to make changes, without notice, in the products, including circuits, standard cells, and/or software, described or contained herein in order to improve design and/or performance. Philips Semiconductors assumes no responsibility or liability for the use of any of these products, conveys no licence or title under any patent, copyright, or mask work right to these products, and makes no representations or warranties that these products are free from patent, copyright, or mask work right infringement, unless otherwise specified.

Multiple voltage regulator with
switch and ignition buffers

TDA3618AJR

NOTES

Multiple voltage regulator with
switch and ignition buffers

TDA3618AJR

NOTES

Philips Semiconductors – a worldwide company

Argentina: see South America

Australia: 3 Figtree Drive, HOMEBUSH, NSW 2140,
Tel. +61 2 9704 8141, Fax. +61 2 9704 8139

Austria: Computerstr. 6, A-1101 WIEN, P.O. Box 213,
Tel. +43 1 60 101 1248, Fax. +43 1 60 101 1210

Belarus: Hotel Minsk Business Center, Bld. 3, r. 1211, Volodarski Str. 6,
220050 MINSK, Tel. +375 172 20 0733, Fax. +375 172 20 0773

Belgium: see The Netherlands

Brazil: see South America

Bulgaria: Philips Bulgaria Ltd., Energoproject, 15th floor,
51 James Bourchier Blvd., 1407 SOFIA,
Tel. +359 2 68 9211, Fax. +359 2 68 9102

Canada: PHILIPS SEMICONDUCTORS/COMPONENTS,
Tel. +1 800 234 7381, Fax. +1 800 943 0087

China/Hong Kong: 501 Hong Kong Industrial Technology Centre,
72 Tat Chee Avenue, Kowloon Tong, HONG KONG,
Tel. +852 2319 7888, Fax. +852 2319 7700

Colombia: see South America

Czech Republic: see Austria

Denmark: Sydhavnsgade 23, 1780 COPENHAGEN V,
Tel. +45 33 29 3333, Fax. +45 33 29 3905

Finland: Sinikalliontie 3, FIN-02630 ESPOO,
Tel. +358 9 615 800, Fax. +358 9 6158 0920

France: 7 - 9 Rue du Mont Valérien, BP317, 92156 SURESNES Cedex,
Tel. +33 1 4728 6600, Fax. +33 1 4728 6638

Germany: Hammerbrookstraße 69, D-20097 HAMBURG,
Tel. +49 40 2353 60, Fax. +49 40 2353 6300

Hungary: Philips Hungary Ltd., H-1119 Budapest, Fehervari ut 84/A,
Tel: +36 1 382 1700, Fax: +36 1 382 1800

India: Philips INDIA Ltd, Band Box Building, 2nd floor,
254-D, Dr. Annie Besant Road, Worli, MUMBAI 400 025,
Tel. +91 22 493 8541, Fax. +91 22 493 0966

Indonesia: PT Philips Development Corporation, Semiconductors Division,
Gedung Philips, Jl. Buncit Raya Kav.99-100, JAKARTA 12510,
Tel. +62 21 794 0040 ext. 2501, Fax. +62 21 794 0080

Ireland: Newstead, Clonskeagh, DUBLIN 14,
Tel. +353 1 7640 000, Fax. +353 1 7640 200

Israel: RAPAC Electronics, 7 Kehilat Saloniki St, PO Box 18053,
TEL AVIV 61180, Tel. +972 3 645 0444, Fax. +972 3 649 1007

Italy: PHILIPS SEMICONDUCTORS, Via Casati, 23 - 20052 MONZA (MI),
Tel. +39 039 203 6838, Fax +39 039 203 6800

Japan: Philips Bldg 13-37, Kohnan 2-chome, Minato-ku,
TOKYO 108-8507, Tel. +81 3 3740 5130, Fax. +81 3 3740 5057

Korea: Philips House, 260-199 Itaewon-dong, Yongsan-ku, SEOUL,
Tel. +82 2 709 1412, Fax. +82 2 709 1415

Malaysia: No. 76 Jalan Universiti, 46200 PETALING JAYA, SELANGOR,
Tel. +60 3 750 5214, Fax. +60 3 757 4880

Mexico: 5900 Gateway East, Suite 200, EL PASO, TEXAS 79905,
Tel. +9-5 800 234 7381, Fax +9-5 800 943 0087

Middle East: see Italy

Netherlands: Postbus 90050, 5600 PB EINDHOVEN, Bldg. VB,
Tel. +31 40 27 82785, Fax. +31 40 27 88399

New Zealand: 2 Wagener Place, C.P.O. Box 1041, AUCKLAND,
Tel. +64 9 849 4160, Fax. +64 9 849 7811

Norway: Box 1, Manglerud 0612, OSLO,
Tel. +47 22 74 8000, Fax. +47 22 74 8341

Pakistan: see Singapore

Philippines: Philips Semiconductors Philippines Inc.,
106 Valero St. Salcedo Village, P.O. Box 2108 MCC, MAKATI,
Metro MANILA, Tel. +63 2 816 6380, Fax. +63 2 817 3474

Poland: Al.Jerozolimskie 195 B, 02-222 WARSAW,
Tel. +48 22 5710 000, Fax. +48 22 5710 001

Portugal: see Spain

Romania: see Italy

Russia: Philips Russia, Ul. Usatcheva 35A, 119048 MOSCOW,
Tel. +7 095 755 6918, Fax. +7 095 755 6919

Singapore: Lorong 1, Toa Payoh, SINGAPORE 319762,
Tel. +65 350 2538, Fax. +65 251 6500

Slovakia: see Austria

Slovenia: see Italy

South Africa: S.A. PHILIPS Pty Ltd., 195-215 Main Road Martindale,
2092 JOHANNESBURG, P.O. Box 58088 Newville 2114,
Tel. +27 11 471 5401, Fax. +27 11 471 5398

South America: Al. Vicente Pinzon, 173, 6th floor,
04547-130 SÃO PAULO, SP, Brazil,
Tel. +55 11 821 2333, Fax. +55 11 821 2382

Spain: Balmes 22, 08007 BARCELONA,
Tel. +34 93 301 6312, Fax. +34 93 301 4107

Sweden: Kottbygatan 7, Akalla, S-16485 STOCKHOLM,
Tel. +46 8 5985 2000, Fax. +46 8 5985 2745

Switzerland: Allmendstrasse 140, CH-8027 ZÜRICH,
Tel. +41 1 488 2741 Fax. +41 1 488 3263

Taiwan: Philips Semiconductors, 5F, No. 96, Chien Kuo N. Rd., Sec. 1,
TAIPEI, Taiwan Tel. +886 2 2134 2451, Fax. +886 2 2134 2874

Thailand: PHILIPS ELECTRONICS (THAILAND) Ltd.,
60/14 MOO 11, Bangna Trad Road KM. 3, Bagna, BANGKOK 10260,
Tel. +66 2 361 7910, Fax. +66 2 398 3447

Turkey: Yukari Dudullu, Org. San. Blg., 2.Cad. Nr. 28 81260 Umraniye,
ISTANBUL, Tel. +90 216 522 1500, Fax. +90 216 522 1813

Ukraine: PHILIPS UKRAINE, 4 Patrice Lumumba str., Building B, Floor 7,
252042 KIEV, Tel. +380 44 264 2776, Fax. +380 44 268 0461

United Kingdom: Philips Semiconductors Ltd., 276 Bath Road, Hayes,
MIDDLESEX UB3 5BX, Tel. +44 208 730 5000, Fax. +44 208 754 8421

United States: 811 East Arques Avenue, SUNNYVALE, CA 94088-3409,
Tel. +1 800 234 7381, Fax. +1 800 943 0087

Uruguay: see South America

Vietnam: see Singapore

Yugoslavia: PHILIPS, Trg N. Pasica 5/v, 11000 BEOGRAD,
Tel. +381 11 3341 299, Fax.+381 11 3342 553

For all other countries apply to: Philips Semiconductors,
Marketing Communications, Building BE-p, P.O. Box 218, 5600 MD EINDHOVEN,
The Netherlands, Fax. +31 40 27 24825

Internet: <http://www.semiconductors.philips.com>

© Philips Electronics N.V. 2001

SCA 72

All rights are reserved. Reproduction in whole or in part is prohibited without the prior written consent of the copyright owner.

The information presented in this document does not form part of any quotation or contract, is believed to be accurate and reliable and may be changed without notice. No liability will be accepted by the publisher for any consequence of its use. Publication thereof does not convey nor imply any license under patent- or other industrial or intellectual property rights.

Printed in The Netherlands

403502/01/pp24

Date of release: 2001 May 02

Document order number: 9397 750 08068

Let's make things better.

Philips
Semiconductors



PHILIPS