

PROTECTION PRODUCTS - RailClamp®
Description

RClamp® TVS diodes are designed to protect sensitive electronics from damage or latch-up due to ESD. They are designed to replace multilayer varistors (MLVs) in portable applications such as cell phones, notebook computers, and other portable electronics. This device offers desirable characteristics for board level protection including fast response time, low operating and clamping voltage, and no device degradation.

RClamp®1851ZA is specifically designed for protection of Near Field Communications (NFC) interfaces. It features extremely good ESD protection characteristics including a low typical dynamic resistance of 0.16 Ohms, low peak ESD clamping voltage, and high ESD withstand voltage (+/-17kV contact per IEC 61000-4-2). Low typical capacitance (0.35pF at VR=0V) means that harmonic distortion the the RF signal is minimized. This device is bidirectional and has a working voltage of 18V for use on NFC resonator circuits without signal clipping.

RClamp1851ZA is in a 2-pin SLP0603P2X3F package measuring 0.6 x 0.3 mm with a nominal height of only 0.25mm. Leads are finished with NiAu. The small package gives the designer the flexibility to protect single lines in applications where arrays are not practical. The combination of small size and high ESD surge capability makes them ideal for use in portable applications such as cellular phones, digital cameras, and tablet PC's.

Features

- ◆ High ESD withstand Voltage: +/-17kV (Contact) and +/- 20kV (Air) per IEC 61000-4-2
- ◆ Ultra-small package
- ◆ Protects one high speed data line
- ◆ Low ESD clamping voltage
- ◆ Working voltage: 18V
- ◆ Low capacitance: 0.35pF typical
- ◆ Low leakage current
- ◆ Extremely low dynamic resistance: 0.16 Ohms (Typ)
- ◆ Solid-state silicon-avalanche technology

Mechanical Characteristics

- ◆ SLP0603P2X3F package
- ◆ Pb-Free, Halogen Free, RoHS/WEEE Compliant
- ◆ Nominal Dimensions: 0.6 x 0.3 x 0.25 mm
- ◆ Lead Finish: NiAu
- ◆ Marking: Marking code
- ◆ Packaging: Tape and Reel

Applications

- ◆ Near Field Communication (NFC) lines
- ◆ RF signal lines
- ◆ Cellular Handsets
- ◆ Tablets
- ◆ FM Antenna

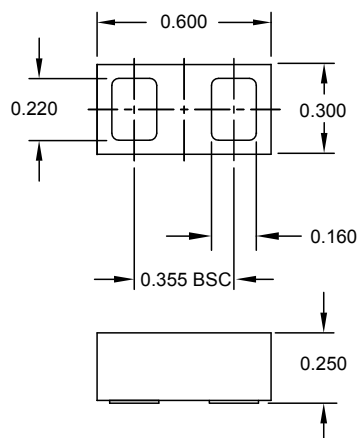
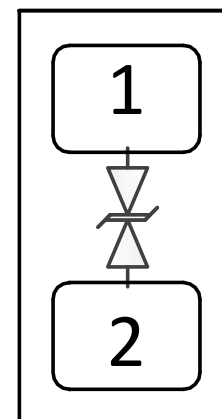
Package Dimensions

Nominal Dimensions in mm
Schematic & Pin Configuration

SLP0603P2X3F (Bottom View)

PROTECTION PRODUCTS

Absolute Maximum Ratings

Rating	Symbol	Value	Units
Peak Pulse Current (tp = 8/20μs)	I_{PP}	3	A
ESD per IEC 61000-4-2 (Air) ⁽¹⁾ ESD per IEC 61000-4-2 (Contact) ⁽¹⁾	V_{ESD}	±20 ±17	kV
Operating Temperature	T_J	-40 to +85	°C
Storage Temperature	T_{STG}	-55 to +150	°C

Electrical Characteristics (T=25°C unless otherwise specified)

Parameter	Symbol	Conditions	Min.	Typ.	Max.	Units
Reverse Stand-Off Voltage	V_{RWM}	T = -40 to +85°C			18	V
Breakdown Voltage	V_{BR}	$I_{BR} = 10\mu A$	18.5	22.5	26.5	V
Reverse Leakage Current	I_R	$V_{RWM} = 18V$		<1	50	nA
ESD Clamping Voltage ²	V_C	$I_{PP} = 4A$ tp = 0.2/100ns		5.5		V
ESD Clamping Voltage ²	V_C	$I_{PP} = 16A$ tp = 0.2/100ns		7.5		V
Dynamic Resistance ^{2,3}	R_{DYN}	tp = 0.2/100ns		0.16		Ohms
Junction Capacitance	C_J	VR = 0V; f = 1MHz		0.35	0.45	pF

Notes

- 1) Measured with a 40dB attenuator, 50 Ohm scope input impedance, 2GHz bandwidth. ESD gun return path connected to ESD ground plane.
- 2) Transmission Line Pulse Test (TLP) Settings: tp = 100ns, tr = 0.2ns, I_{TLP} and V_{TLP} averaging window: t1 = 70ns to t2 = 90ns.
- 3) Dynamic resistance calculated from $I_{TLP} = 4A$ to $I_{TLP} = 16A$
- 4) Device is electrically symmetrical

PROTECTION PRODUCTS

Typical Characteristics

ESD Clamping (8kV Contact per IEC 61000-4-2)

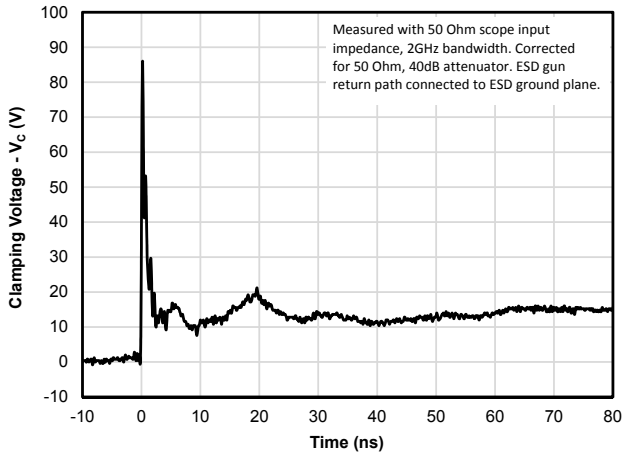

ESD Clamping (-8kV Contact per IEC 61000-4-2)

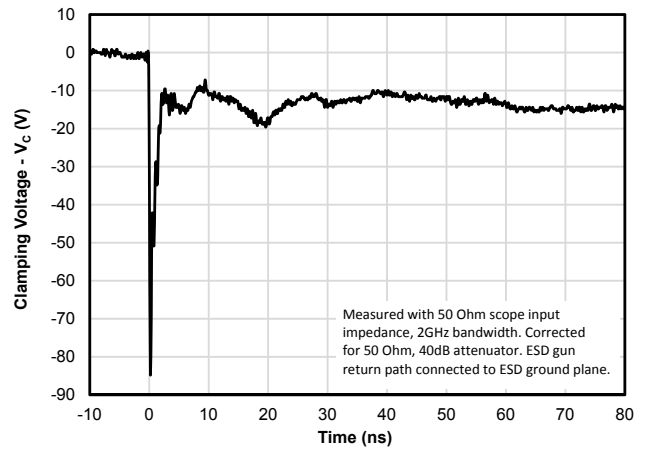

TLP Characteristic (Positive Pulse)

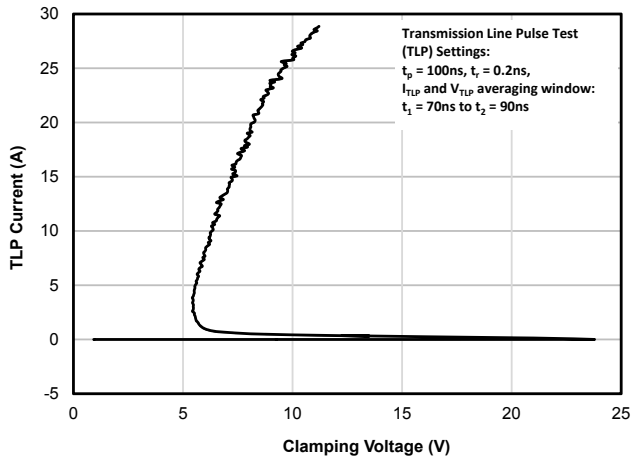

TLP Characteristic (Negative Pulse)

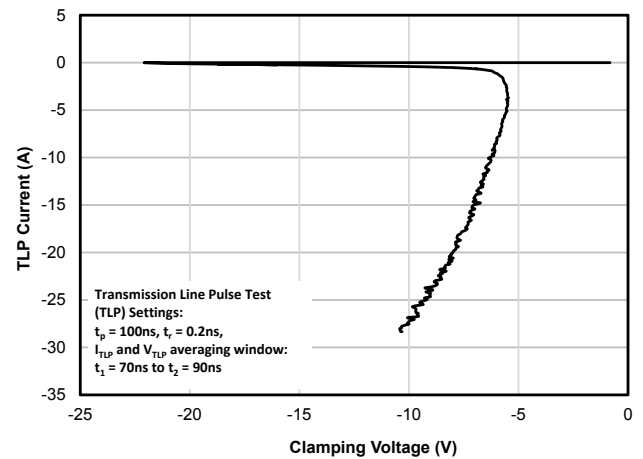

Capacitance vs. Reverse Voltage

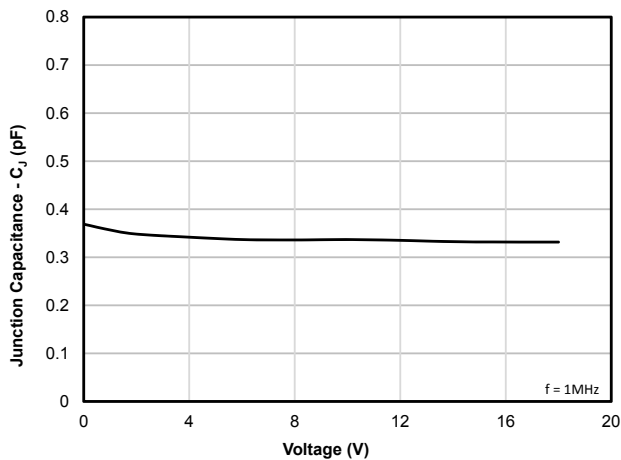

Insertion Loss - S21 (dB)

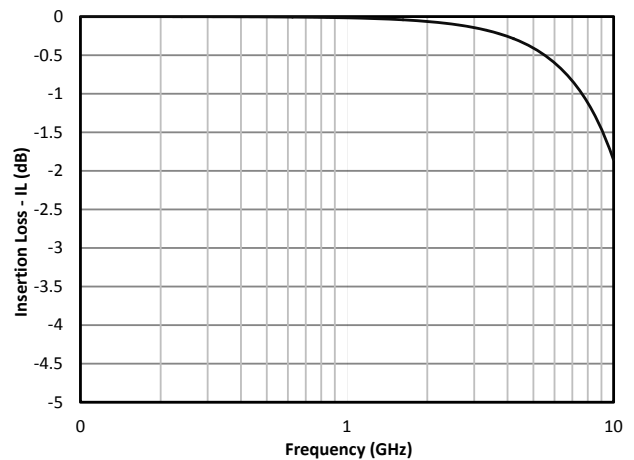

ESD Protection of NFC Interfaces

The Near Field Communication (NFC) antenna is usually connected to the NFC controller IC via contact points on the phone. These contact points are user accessible and therefore may be subjected to ESD strikes. External protection (TVS) devices should be placed between the antenna and the NFC chip interface. The working voltage of the TVS should be high enough as not to clip the NFC signal. Additionally, the capacitance of the device

should be minimized in order to avoid harmonic distortion of the RF signal. RClamp1851ZA meets these requirements and also features extremely low dynamic resistance resulting in low ESD clamping voltage. The low dynamic resistance also helps insure protection for Schottky diodes that may be used in the NFC circuit. RClamp1851ZA is designed to work on NFC circuits with AC signals as high as 18V. An example protection circuit is shown below in Figure 1.

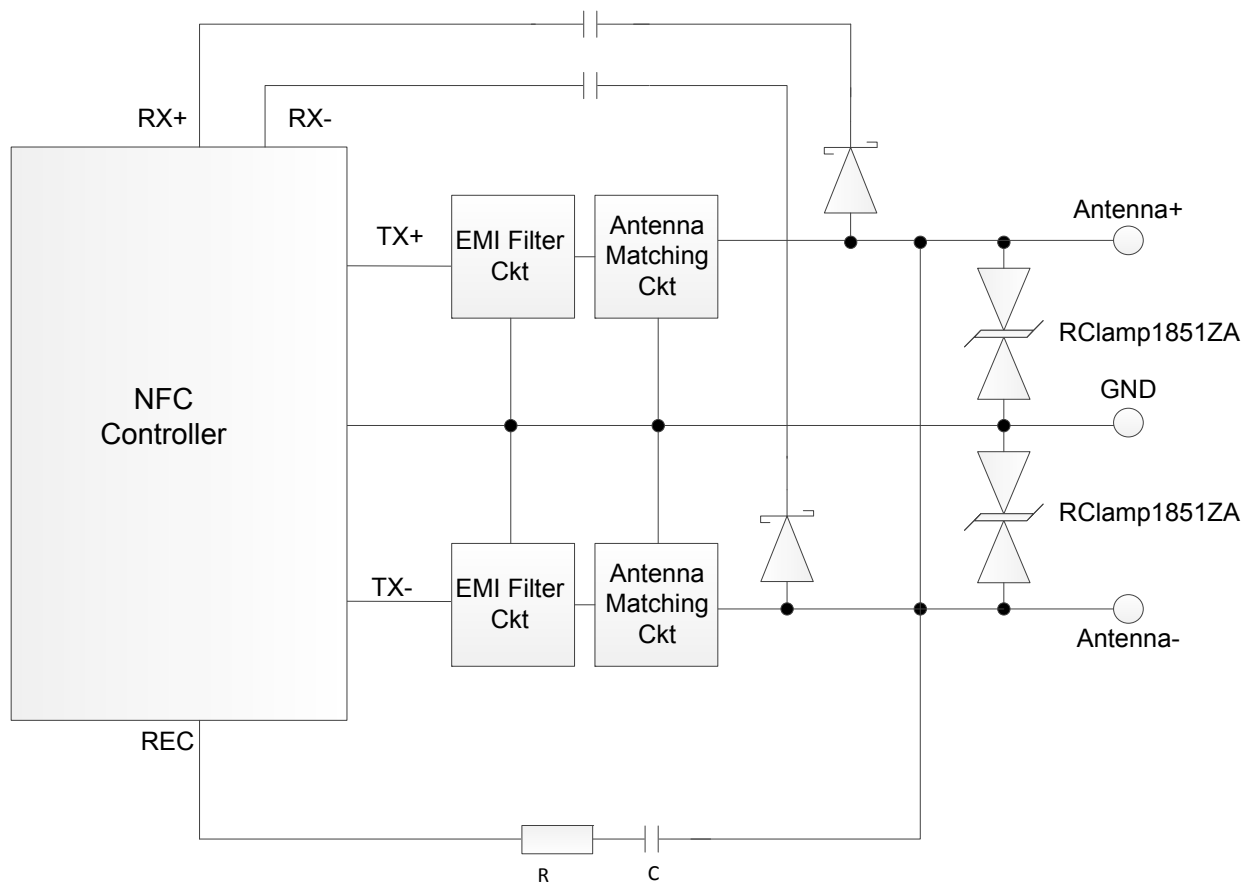

Figure 1 - NFC Protection Example

PROTECTION PRODUCTS

Applications Information

Assembly Guidelines

The small size of this device means that some care must be taken during the mounting process to insure reliable solder joint. The table below provides Semtech's recommended assembly guidelines for mounting this device. The figure at the right details Semtech's recommended aperture based on the below recommendations. Note that these are only recommendations and should serve only as a starting point for design since there are many factors that affect the assembly process. The exact manufacturing parameters will require some experimentation to get the desired solder application.

Assembly Parameter	Recommendation
Solder Stencil Design	Laser cut, Electro-polished
Aperture shape	Rectangular with rounded corners
Solder Stencil Thickness	0.100 mm (0.004")
Solder Paste Type	Type 4 size sphere or smaller
Solder Reflow Profile	Per JEDEC J-STD-020
PCB Solder Pad Design	Non-Solder mask defined
PCB Pad Finish	OSP OR NiAu

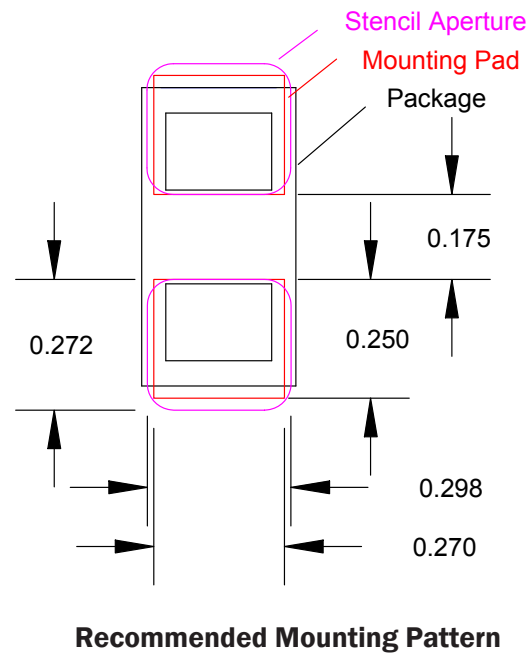

PROTECTION PRODUCTS

Outline Drawing - SLP0603P2X3F

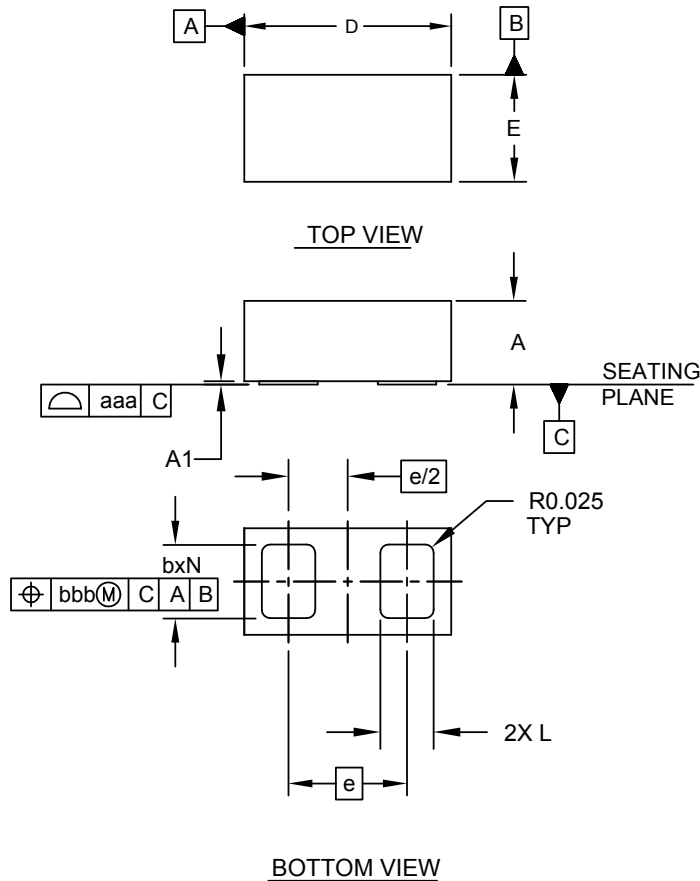

DIM	DIMENSIONS		
	MILLIMETERS		
	MIN	NOM	MAX
A	0.235	0.250	0.265
A1	0.000	0.010	0.050
b	0.200	0.220	0.240
D	0.580	0.600	0.620
E	0.280	0.300	0.320
e	0.355 BSC		
L	0.140	0.160	0.180
N	2		
aaa	0.08		
bbb	0.10		

- NOTES:
1. CONTROLLING DIMENSIONS ARE IN MILLIMETERS (ANGLES IN DEGREES).

Land Pattern - SLP0603P2X3F

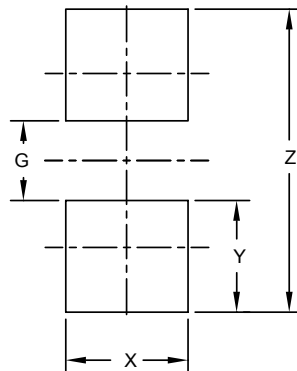

DIM	DIMENSIONS
	MILLIMETERS
G	0.177
X	0.272
Y	0.247
Z	0.671

- NOTES:
- CONTROLLING DIMENSIONS ARE IN MILLIMETERS (ANGLES IN DEGREES).
 - THIS LAND PATTERN IS FOR REFERENCE PURPOSES ONLY.
 - CONSULT YOUR MANUFACTURING GROUP TO ENSURE YOUR COMPANY'S MANUFACTURING GUIDELINES ARE MET.

PROTECTION PRODUCTS

Marking

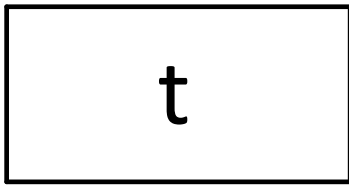

Notes: Device is Electrically Symmetrical

Ordering Information

Part Number	Qty per Reel	Reel Size
RClamp1851ZATFT	15000	7"

Notes:

1) RailClamp and RClamp are trademarks of Semtech Corporation.

Tape and Reel Specification

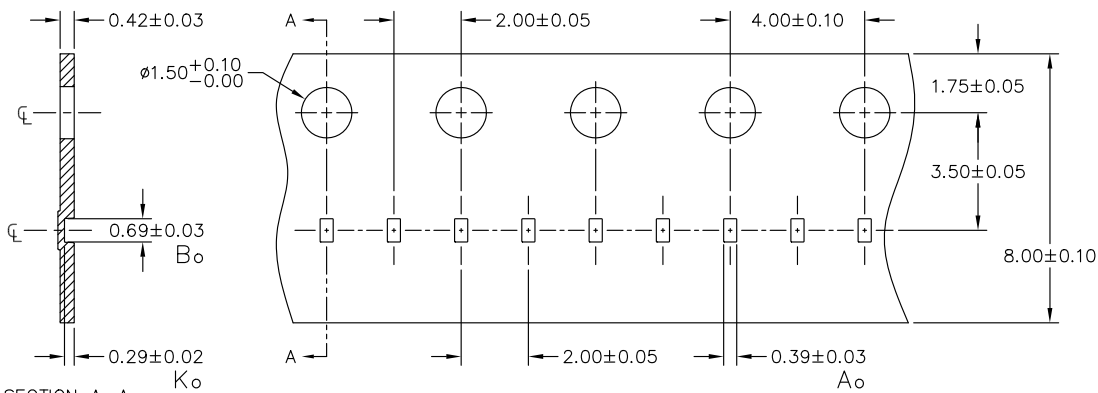

NOTES: ALL DIMENSIONS IN MILLIMETERS UNLESS OTHERWISE SPECIFIED.

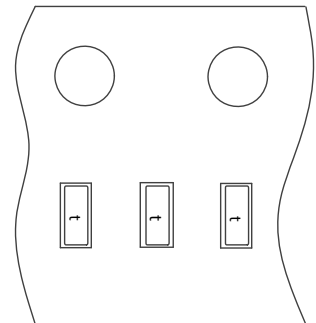

Contact Information

Semtech Corporation
 Protection Products Division
 200 Flynn Rd., Camarillo, CA 93012
 Phone: (805)498-2111 FAX (805)498-3804