

DESCRIPTION

The EV4689DN-00A is an evaluation board for high power LED driver. It is implemented by MP4689DN, an integrated Buck white LED driver which is suitable for automotive, industry and general lighting applications with MPS patented pending technology.

The EV4689DN-00A is recommended to drive a single-string LEDs. It can drive up to 19 LEDs in one string. It regulates the LED current at about 730mA.

ELECTRICAL SPECIFICATIONS

Parameter	Symbol	Value	Units
Input Voltage	VIN	4.5 to 95	V
Enable/Dimming	EN/DIM	5	V
LED Current	I _{LED}	730	mA
Over Current Protection	OCP	2.5	A

FEATURES

- Wide 4.5V to 100V Operating Input Range
- No Output Capacitor Required
- ±5% LED Current Accuracy
- Hysteretic Control: No Compensation
- Up to 2MHz Switching Frequency
- Up to 20kHz Dimming Frequency
- Dedicated PWM Dimming Control Input
- Short circuit protection with integrated high side MOSFET
- Optional Output Voltage Limitation
- Thermal shut down
- 200mV reference voltage for high efficiency
- Up to 95% Efficiency
- 120µA Quiescent Current
- Available in SOIC8 with Exposed Pad Packages

APPLICATIONS

- High Power LED Driver
- Automotive, Industry and General Lighting
- Constant Current Source

For MPS green status, please visit MPS website under Quality Assurance. "MPS" and "The Future of Analog IC Technology" are Registered Trademarks of Monolithic Power Systems, Inc.

EV4689DN-00A EVALUATION BOARD

Components Area: 0.66" x 1.17" (1.7cm x 3cm)

Board Number	MPS IC Number
EV4689DN-00A	MP4689

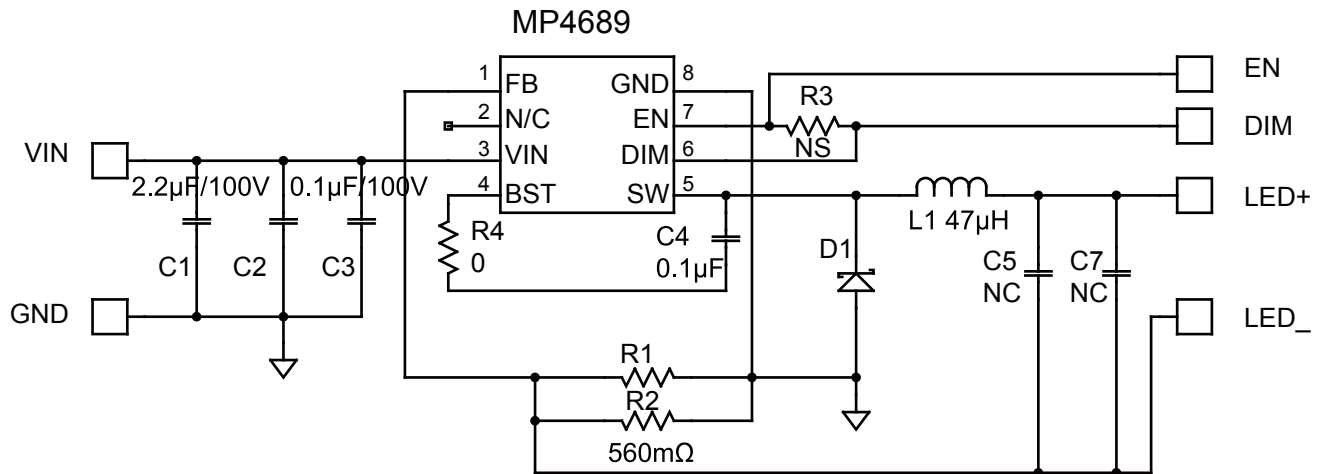
EVALUATION BOARD SCHEMATIC

EV4689DN-00A BILL OF MATERIALS

Qty	RefDes	Value	Description	Package	Manufacturer	Manufacturer P/N
2	C1,C2	2.2µF	Ceramic Cap., 100V, 10%, X7R	1210	muRata	GRM32ER72A225K
1	C3	0.1µF	Ceramic Cap., 100V, 10%, X7R	0805	muRata	GCM21BR72A104K
2	C4	0.1µF	Ceramic Cap., 50V, 10%, X7R	0603	muRata	GRM188R71H104K
0	C5,C7	NS		0603		
1	D1	1A	Schottky Rect., 150V, 1A	SMA	Diodes	STPS1150A
1	L1	47µH	Inductor, Rdc 100mΩ, Isat 2.7A	SMD	Würth Elektronik	744770147
2	R1,R2	560mΩ	Film Res., 1/8W, 1%	0805	Panasonic	ERJ-6RQFR56V
0	R3	NS		0603		
1	R4	0Ω	Film Res., 5%	0603	Yageo	RC0603JR-070RL
1	U1		Power Led Driver	SO8E	MPS	MP4689DN(R0)
1	EN,DIM,GND		4 Pin Header, 2.54mm	2.54mm	Sullins	PCC04SAAN
4	LED+,LED-,VIN,GND		2.3 pillar	W200D100	HZ	China

TYPICAL PERFORMANCE CHARACTERISTICS

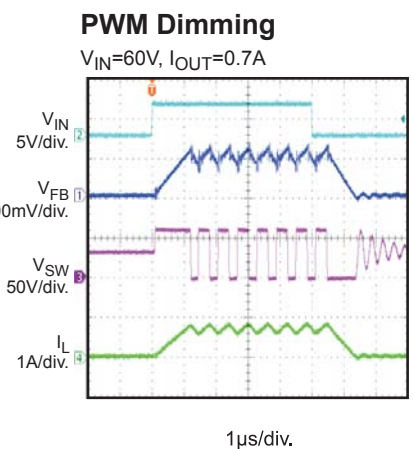
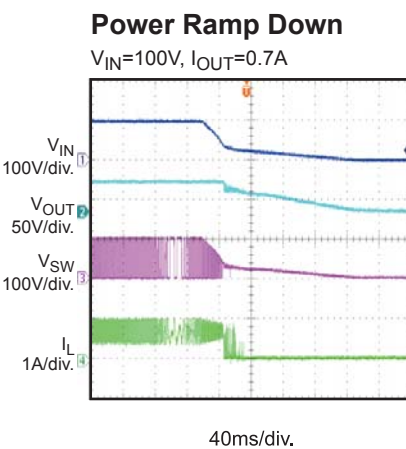
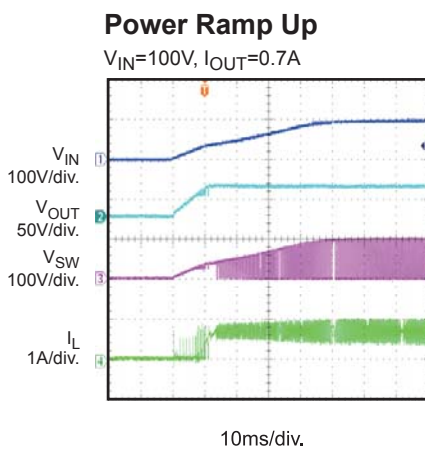
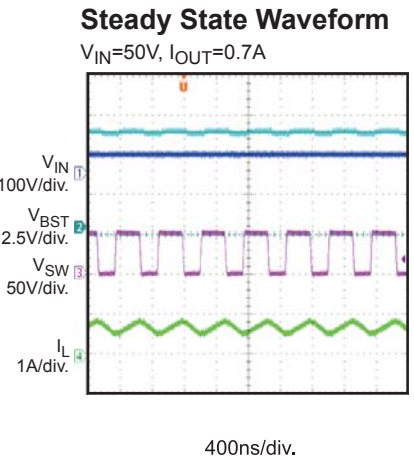
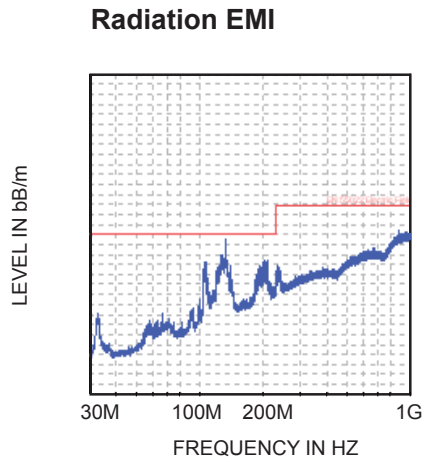
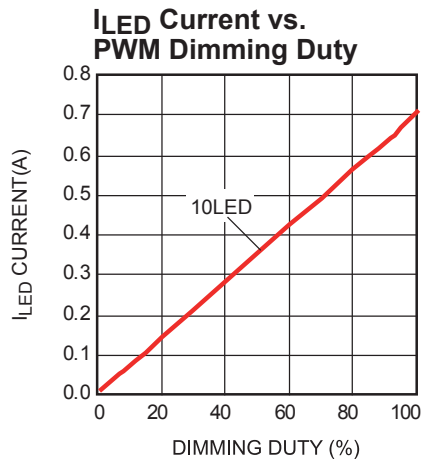
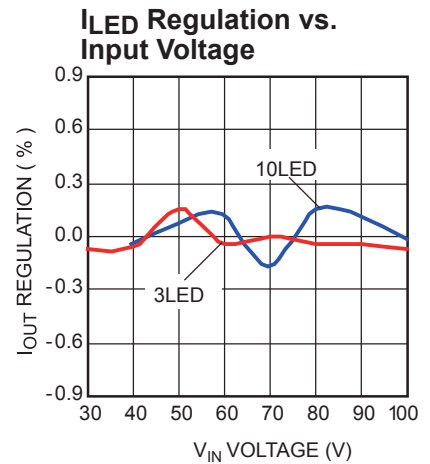
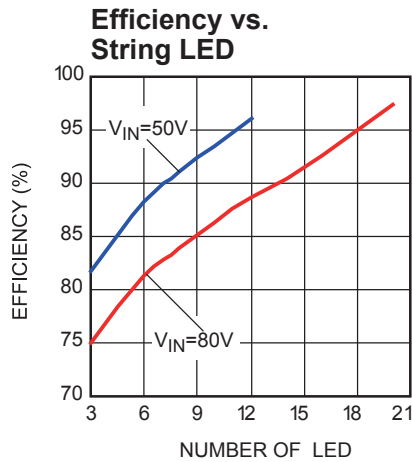
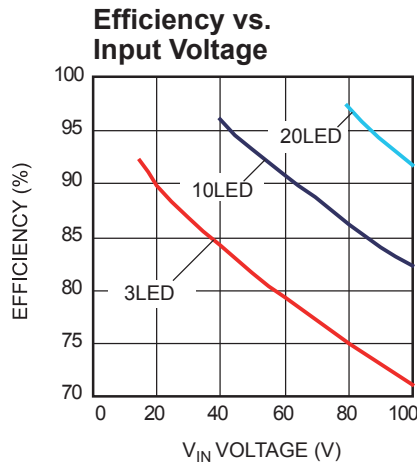
$V_{IN}=20V$ to $90V$, $V_{OUT}=3.5V$ to $70V$, $L=33\mu H$, $T_A=25^\circ C$, Unless otherwise noted.



PRINTED CIRCUIT BOARD LAYOUT

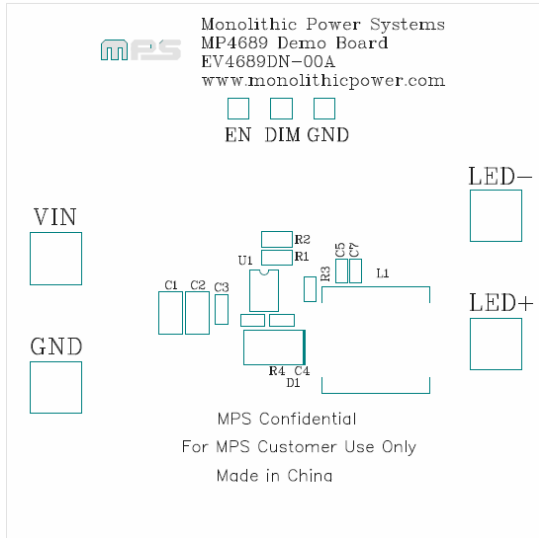

Figure 1—Top Silk Layer

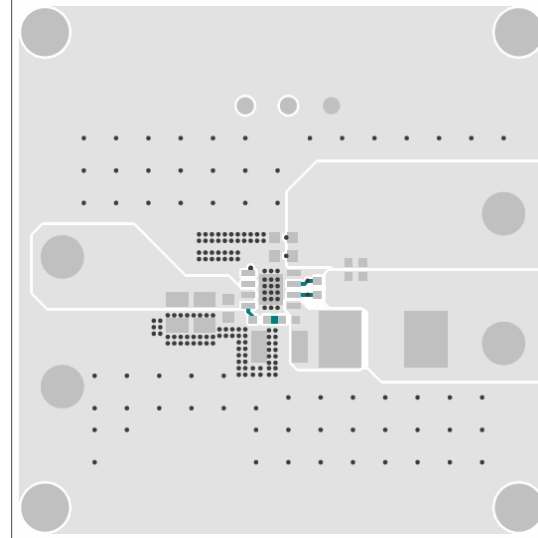

Figure 2—Top Layer

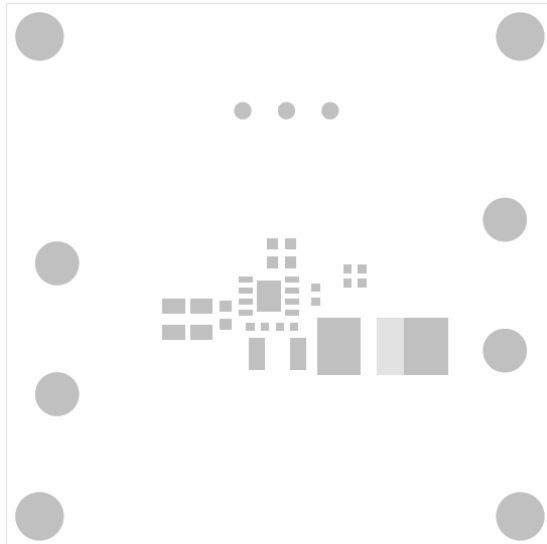

Figure 3—Top Mask Layer

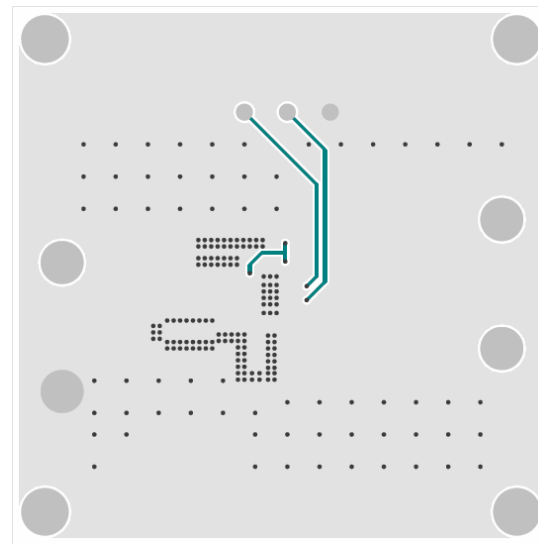

Figure 4—Bottom Layer

QUICK START GUIDE

1. Check the LED string voltage and preset the power supplies' Voltage for input. For example, 10 LEDs have about 32V forward voltage drop. So the power supply should be set higher than 32V, say set it to 60V. Set a second power supply to 5V for enable signal. Setup a signal generator to generate PWM signal with 5V amplitude, 20kHz frequency and 50% duty cycle.
2. Turn-off all power supplies.
3. Connect the LED+ to the anode of the string and LED- to the cathode of the string. Connect the VIN to the first power supply (60V). Connect the EN to the 5V power supply. Connect the DIM to signal generator.
4. Turn on the high voltage power supply (60V).
5. Turn on the signal generator.
6. Turn on the 5V power supply.

Note: If do not need dimming function, place a 0Ω resistor at R3, which will connect DIM to EN.

NOTICE: The information in this document is subject to change without notice. Users should warrant and guarantee that third party Intellectual Property rights are not infringed upon when integrating MPS products into any application. MPS will not assume any legal responsibility for any said applications.