



FIRC5730W09-B20

SMD Type 730nm Infrared Emitter

CT Microelectronics

Features

- High reliability
- High total radiated power
- Good spectral matching to Si photo detector
- RoHS compliance

Applications

- Infrared sensor
- Light barrier

Description

The FIRC5730W09-B20 is a GaAlAs infrared LED housed in a miniature SMD package. The device has a peak wavelength of 730nm LED.

Package Outline

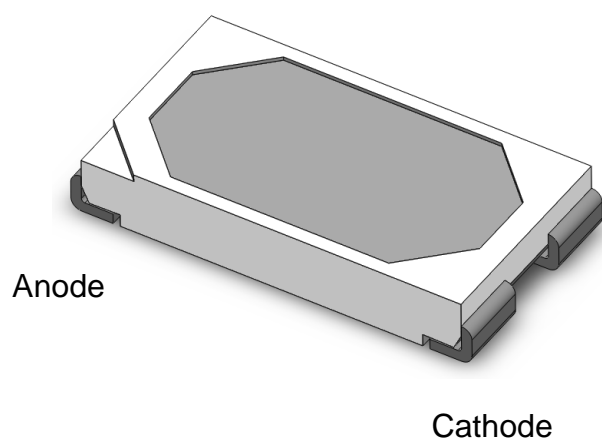

Schematic

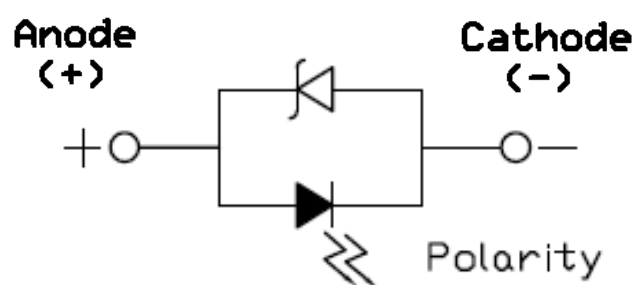

**Absolute Maximum Rating at 25°C**

Symbol	Parameters	Ratings	Units	Notes
I _F	Continuous Forward Current	150	mA	
I _{FP}	Peak Forward Current	1.0	A	1
V _R	Reverse Voltage	5	V	
T _{opr}	Operating Temperature	-40 ~ +85	°C	
T _{stg}	Storage Temperature	-40 ~ +100	°C	
T _{sol}	Soldering Temperature	260	°C	2
P _D	Power Dissipation at(or below) 25°C Free Air Temperature	510	mW	

Electro-Optical Characteristics TA = 25°C (unless otherwise specified)**Optical Characteristics**

Symbol	Parameters	Test Conditions	Min	Typ	Max	Units	Notes
I _e	Radiant Intensity	I _F =20mA	-	5.0	-	mW/sr	
		I _F =100mA	-	25.3	-		
		I _F =150mA	-	37.6	-		
P _o	Total radiated power	I _F =20mA	-	15.7	-	mW	
		I _F =100mA	-	80	-		
		I _F =150mA	-	118	-		
λ _p	Peak Wavelength	I _F =20mA	720	730	750	nm	
Δλ	Spectral Bandwidth	I _F =20mA	-	25	-	nm	
θ _{1/2}	Angle of Half Intensity	I _F =20mA	-	±60	-	deg	

Electrical Characteristics

Symbol	Parameters	Test Conditions	Min	Typ	Max	Units	Notes
V _F	Forward Voltage	I _F =20mA	1.7	2.0	2.4	V	
		I _F =100mA	2.2	2.5	3.1		
		I _F =150mA	2.3	2.7	3.4		
I _R	Reverse Current	V _R =5V	-	-	10	μA	

Notes:1 : I_{FP} Conditions--Pulse Width ≤ 100μs and Duty ≤ 1%.

2 : Soldering time ≤ 5 seconds.



Typical Characteristic Curves

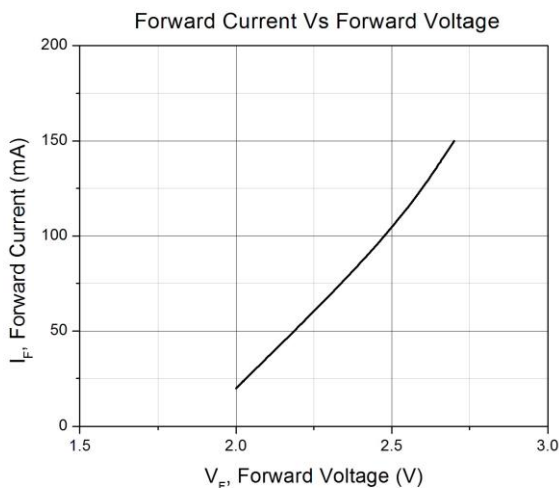

Figure 1

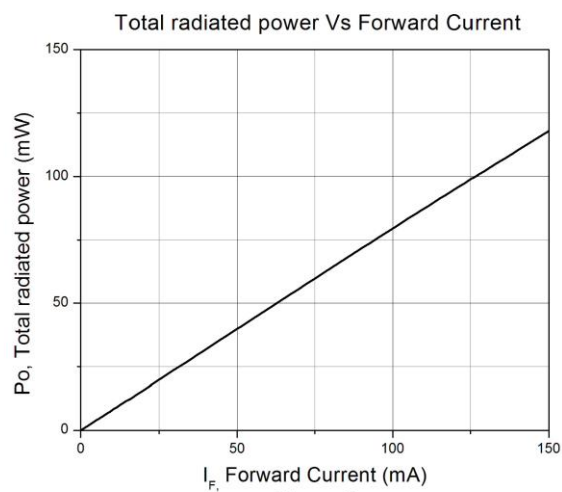

Figure 2

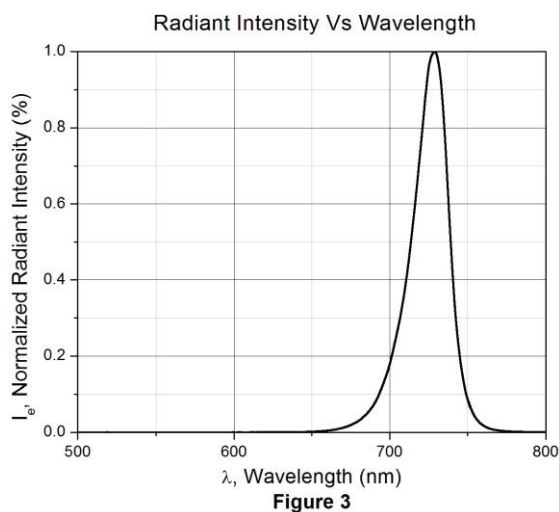

Figure 3

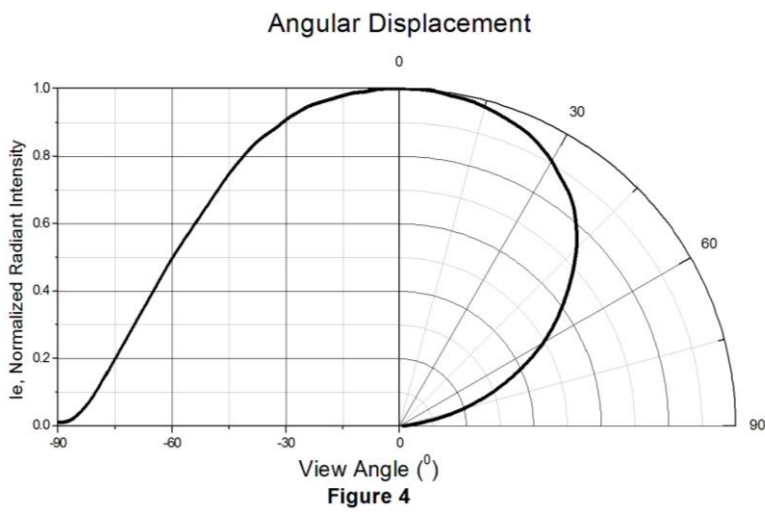
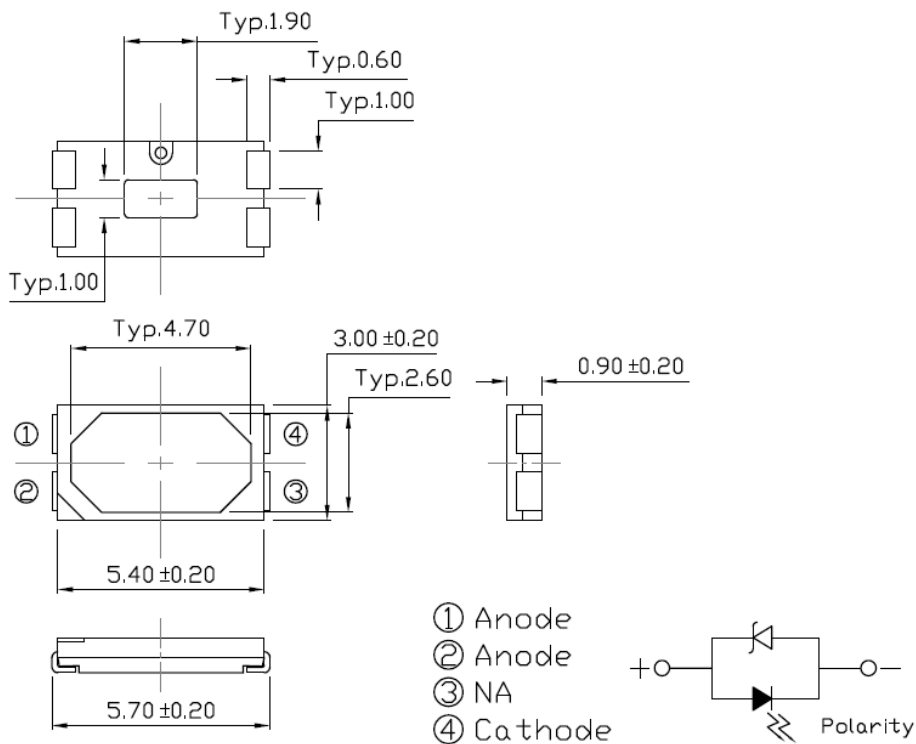

Figure 4



Package Dimension

All dimensions are in mm, unless otherwise stated.



Recommended Soldering Mask

All dimensions are in mm, unless otherwise stated

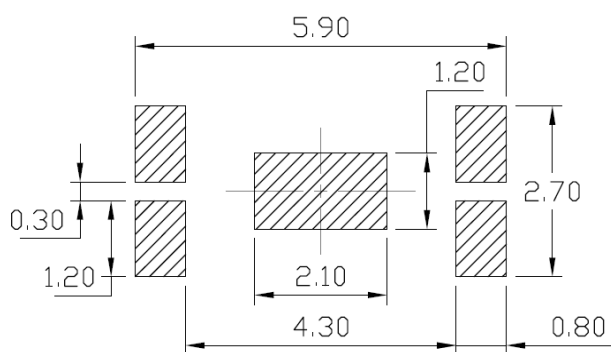

Ordering Information

Part Number	Description	Quantity
FIRC5730W09-B20	Tape & Reel	2000 pcs



CT Microelectronics

Reel Dimension

All dimensions are in mm, unless otherwise stated

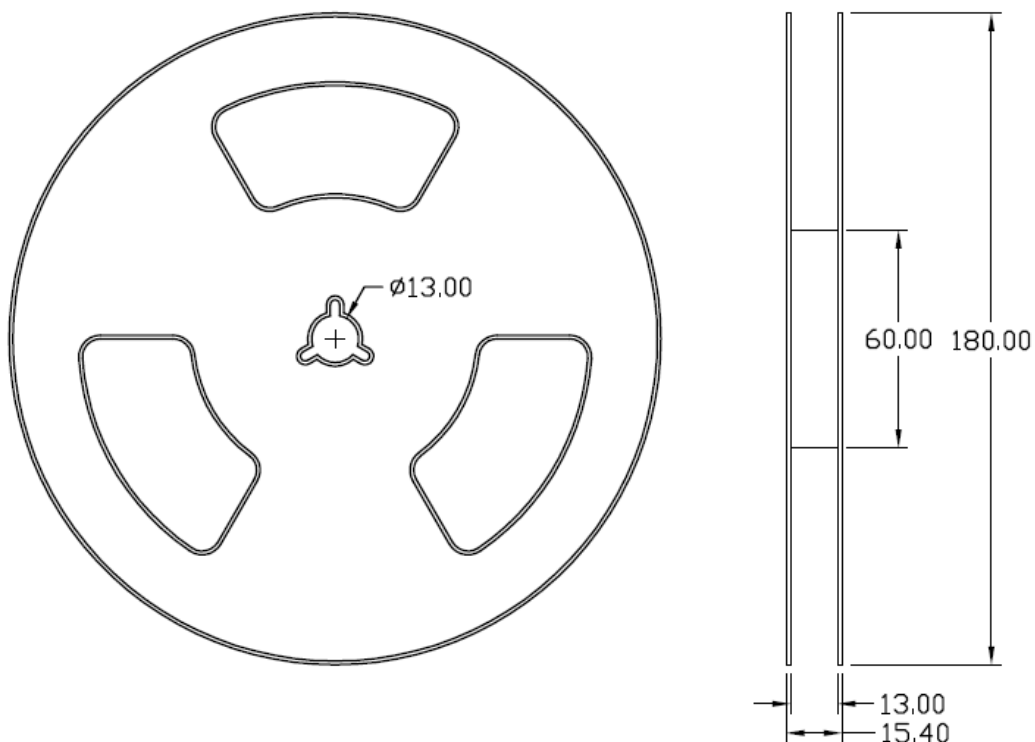

Tape Dimension

All dimensions are in mm, unless otherwise stated

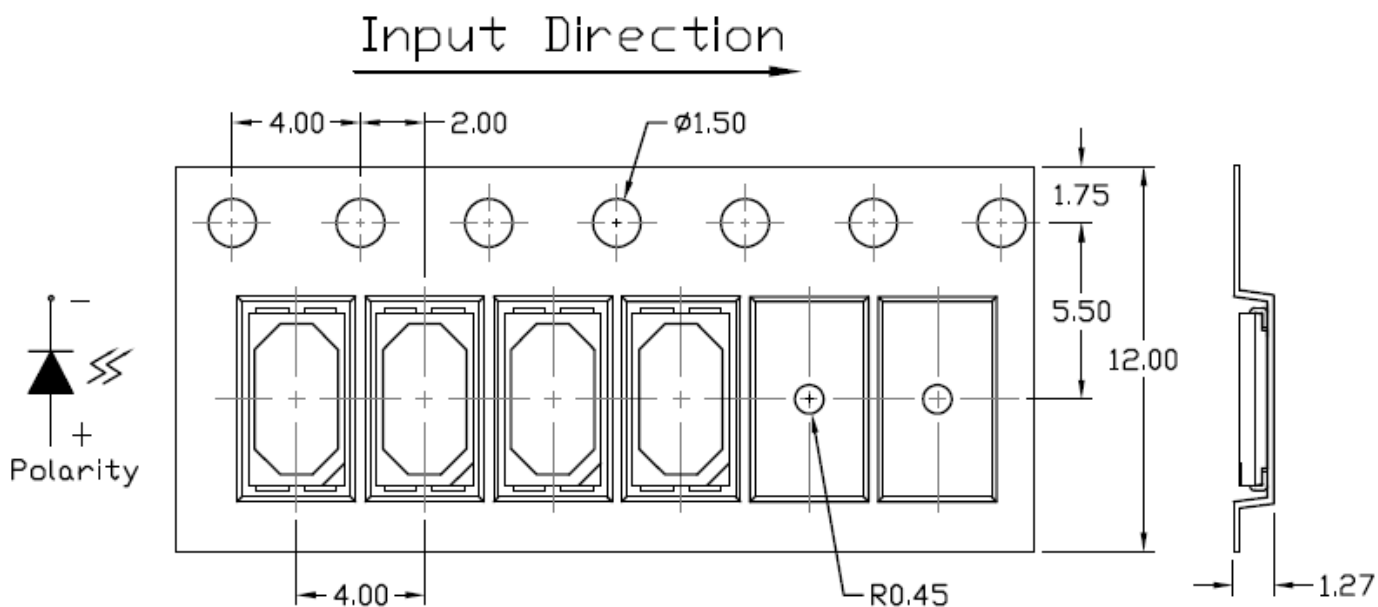



Reflow Profile

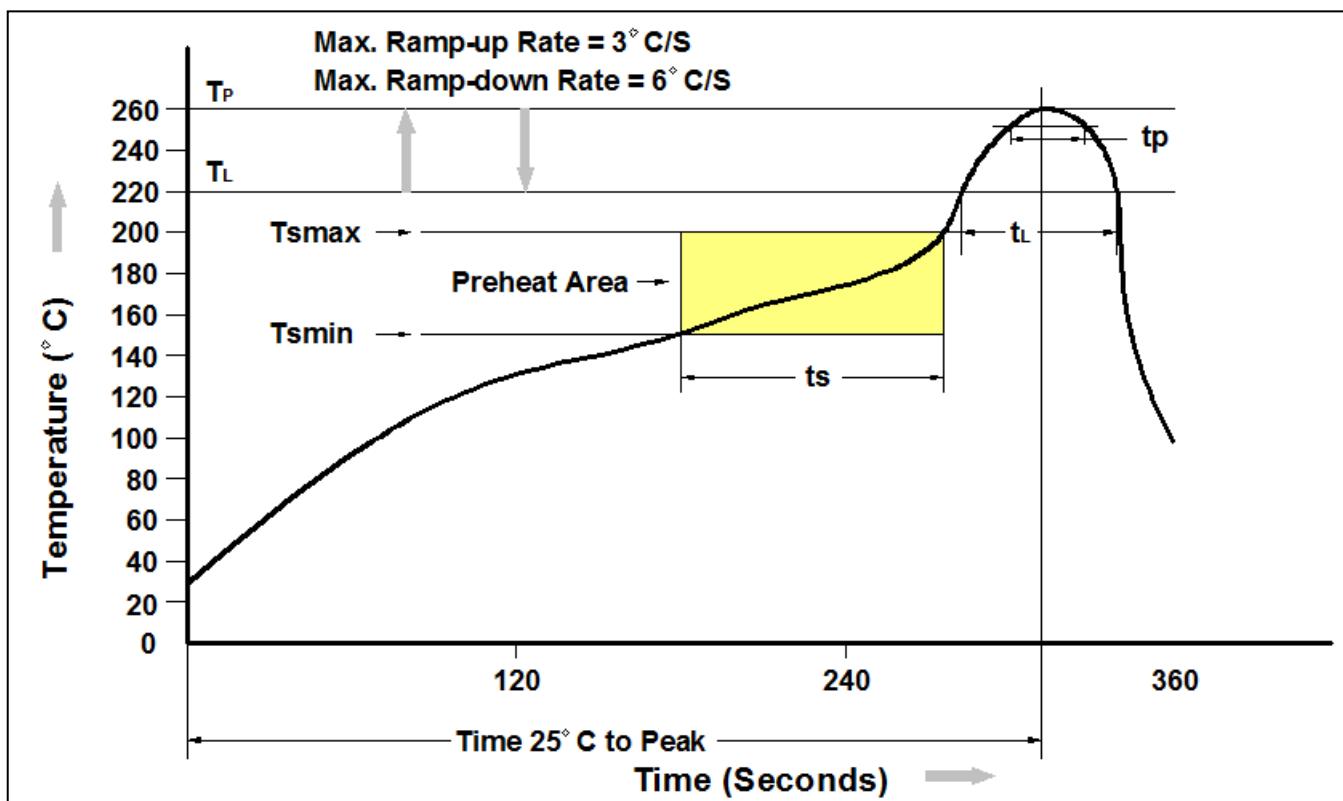

Profile Feature	Pb-Free Assembly Profile
Temperature Min. (T _{smin})	150°C
Temperature Max. (T _{smax})	200°C
Time (t _s) from (T _{smin} to T _{smax})	60-120 seconds
Ramp-up Rate (t _L to t _P)	3°C/second max.
Liquidous Temperature (T _L)	217°C
Time (t _L) Maintained Above (T _L)	60 – 150 seconds
Peak Body Package Temperature	260°C +0°C / -5°C
Time (t _P) within 5°C of 260°C	30 seconds
Ramp-down Rate (T _P to T _L)	6°C/second max
Time 25°C to Peak Temperature	8 minutes max.



DISCLAIMER

CT MICROELECTRONICS RESERVES THE RIGHT TO MAKE CHANGES WITHOUT FURTHER NOTICE TO ANY PRODUCTS HEREIN TO IMPROVE RELIABILITY, FUNCTION OR DESIGN. CT MICRO DOES NOT ASSUME ANY LIABILITY ARISING OUT OF THE APPLICATION OR USE OF ANY PRODUCT OR CIRCUIT DESCRIBED HEREIN; NEITHER DOES IT CONVEY ANY LICENSE UNDER ITS PATENT RIGHTS, NOR THE RIGHTS OF OTHERS.

CT MICROELECTRONICS ARE NOT AUTHORIZED FOR USE AS CRITICAL COMPONENTS IN LIFE SUPPORT DEVICES OR SYSTEMS WITHOUT EXPRESS WRITTEN APPROVAL OF CT MICROELECTRONICS LTD.

- 1. Life support devices or systems are devices or systems which, (a) are intended for surgical implant into the body, or (b) support or sustain life, or (c) whose failure to perform when properly used in accordance with instruction for use provided in the labeling, can be reasonably expected to result in significant injury to the user.*
- 2. A critical component is any component of a life support device or system whose failure to perform can be reasonably expected to cause the failure of the life support device or system, or to affect its safety or effectiveness.*