

DATA SHEET

RM10/I
RM, RM/I, RM/ILP cores and
accessories

Supersedes data of September 2004

2008 Sep 01

CORE SETS

Effective core parameters

SYMBOL	PARAMETER	VALUE	UNIT
$\Sigma(l/A)$	core factor (C1)	0.462	mm ⁻¹
V_e	effective volume	4310	mm ³
l_e	effective length	44.6	mm
A_e	effective area	96.6	mm ²
A_{min}	minimum area	89.1	mm ²
m	mass of set	≈ 22	g

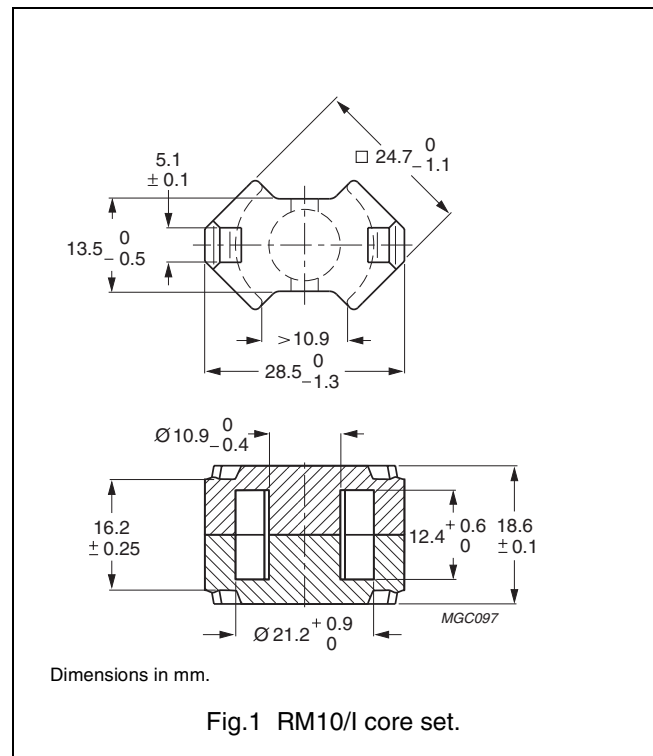

Core sets for filter applications

Clamping force for A_L measurements, 60 ±20 N.

GRADE	A_L (nH)	μ_e	AIR GAP (μm)	TYPE NUMBER
3D3	315 ±3%	≈ 116	≈ 380	RM10/I-3D3-A315
	400 ±5%	≈ 147	≈ 280	RM10/I-3D3-A400
	630 ±8%	≈ 232	≈ 140	RM10/I-3D3-A630
	1900 ±25%	≈ 700	≈ 0	RM10/I-3D3
3H3	400 ±3%	≈ 147	≈ 330	RM10/I-3H3-A400
	630 ±3%	≈ 232	≈ 190	RM10/I-3H3-A630
	1000 ±10%	≈ 367	≈ 110	RM10/I-3H3-A1000
	4400 ±25%	≈ 1620	≈ 0	RM10/I-3H3

Core sets for general purpose transformers and power applications

Clamping force for A_L measurements, 60 ±20 N.

GRADE	A_L (nH)	μ_e	TOTAL AIR GAP (μm)	TYPE NUMBER
3C81	160 ±3%	≈ 59	≈ 980	RM10/I-3C81-E160
	250 ±3%	≈ 92	≈ 570	RM10/I-3C81-A250
	315 ±3%	≈ 116	≈ 430	RM10/I-3C81-A315
	400 ±3%	≈ 147	≈ 330	RM10/I-3C81-A400
	630 ±3%	≈ 232	≈ 190	RM10/I-3C81-A630
	5500 ±25%	≈ 2020	≈ 0	RM10/I-3C81

GRADE	A_L (nH)	μ_e	TOTAL AIR GAP (μm)	TYPE NUMBER
3C90	160 \pm 3%	\approx 59	\approx 980	RM10/I-3C90-A160
	250 \pm 3%	\approx 92	\approx 570	RM10/I-3C90-A250
	315 \pm 3%	\approx 116	\approx 430	RM10/I-3C90-A315
	400 \pm 3%	\approx 147	\approx 330	RM10/I-3C90-A400
	630 \pm 3%	\approx 232	\approx 190	RM10/I-3C90-A630
	4500 \pm 25%	\approx 1650	\approx 0	RM10/I-3C90
3C91 des	5500 \pm 25%	\approx 2020	\approx 0	RM10/I-3C91
3C94	160 \pm 3%	\approx 59	\approx 980	RM10/I-3C94-A160
	250 \pm 3%	\approx 92	\approx 570	RM10/I-3C94-A250
	315 \pm 3%	\approx 116	\approx 430	RM10/I-3C94-A315
	400 \pm 3%	\approx 147	\approx 330	RM10/I-3C94-A400
	630 \pm 3%	\approx 232	\approx 190	RM10/I-3C94-A630
	4500 \pm 25%	\approx 1650	\approx 0	RM10/I-3C94
3C95 des	5500 \pm 25%	\approx 2020	\approx 0	RM10/I-3C95
3C96 des	4050 \pm 25%	\approx 1680	\approx 0	RM10/I-3C96
3F3	160 \pm 3%	\approx 59	\approx 980	RM10/I-3F3-A160
	250 \pm 3%	\approx 92	\approx 570	RM10/I-3F3-A250
	315 \pm 3%	\approx 116	\approx 430	RM10/I-3F3-A315
	400 \pm 3%	\approx 147	\approx 330	RM10/I-3F3-A400
	630 \pm 3%	\approx 232	\approx 190	RM10/I-3F3-A630
	4050 \pm 25%	\approx 1490	\approx 0	RM10/I-3F3
3F35 prot	3100 \pm 25%	\approx 1190	\approx 0	RM10/I-3F35

Core sets of high permeability gradesClamping force for AL measurements, 60 \pm 20 N.

GRADE	A_L (nH)	μ_e	TYPE NUMBER
3E27	10700 \pm 25%	\approx 3930	RM10/I-3E27
3E5	16000 +40/-30%	\approx 5880	RM10/I-3E5

Properties of core sets under power conditions

GRADE	B (mT) at	CORE LOSS (W) at				
	H = 250 A/m; f = 25 kHz; T = 100 °C	f = 25 kHz; B̂ = 200 mT; T = 100 °C	f = 100 kHz; B̂ = 100 mT; T = 100 °C	f = 100 kHz; B̂ = 200 mT; T = 25 °C	f = 100 kHz; B̂ = 200 mT; T = 100 °C	f = 400 kHz; B̂ = 50 mT; T = 100 °C
3C81	≥315	≤ 1.0	–	–	–	–
3C90	≥320	≤ 0.52	≤ 0.55	–	–	–
3C91	≥315	–	≤ 0.3 ⁽¹⁾	–	≤ 1.8 ⁽¹⁾	–
3C94	≥320	–	≤ 0.41	–	≤ 2.3	–
3C95	≥320	–	–	≤ 2.54	≤ 2.41	–
3C96	≥340	–	≤ 0.3	–	≤ 1.8	≤ 0.77
3F3	≥315	–	≤ 0.48	–	–	≤ 0.82
3F35	≥315	–	–	–	–	–

Properties of core sets under power conditions (continued)

GRADE	B (mT) at	CORE LOSS (W) at			
	H = 250 A/m; f = 25 kHz; T = 100 °C	f = 500 kHz; B̂ = 50 mT; T = 100 °C	f = 500 kHz; B̂ = 100 mT; T = 100 °C	f = 1 MHz; B̂ = 30 mT; T = 100 °C	f = 3 MHz; B̂ = 10 mT; T = 100 °C
3C96	≥340	≤ 1.5	–	–	–
3F3	≥315	–	–	–	–
3F35	≥315	≤ 0.6	≤ 4.5	–	–

Note

1. Measured at 60 °C.

COIL FORMER

General data

PARAMETER	SPECIFICATION
Coil former material	polybutyleneterephthalate (PBT), glass-reinforced, flame retardant in accordance with UL 94V-0; UL file number E45329(R)
Pin material	copper-tin alloy (CuSn), tin (Sn) plated
Maximum operating temperature	155 °C, "IEC 60085", class F
Resistance to soldering heat	"IEC 60068-2-20", Part 2, Test Tb, method 1B, 350 °C, 3.5 s
Solderability	"IEC 60068-2-20", Part 2, Test Ta, method 1

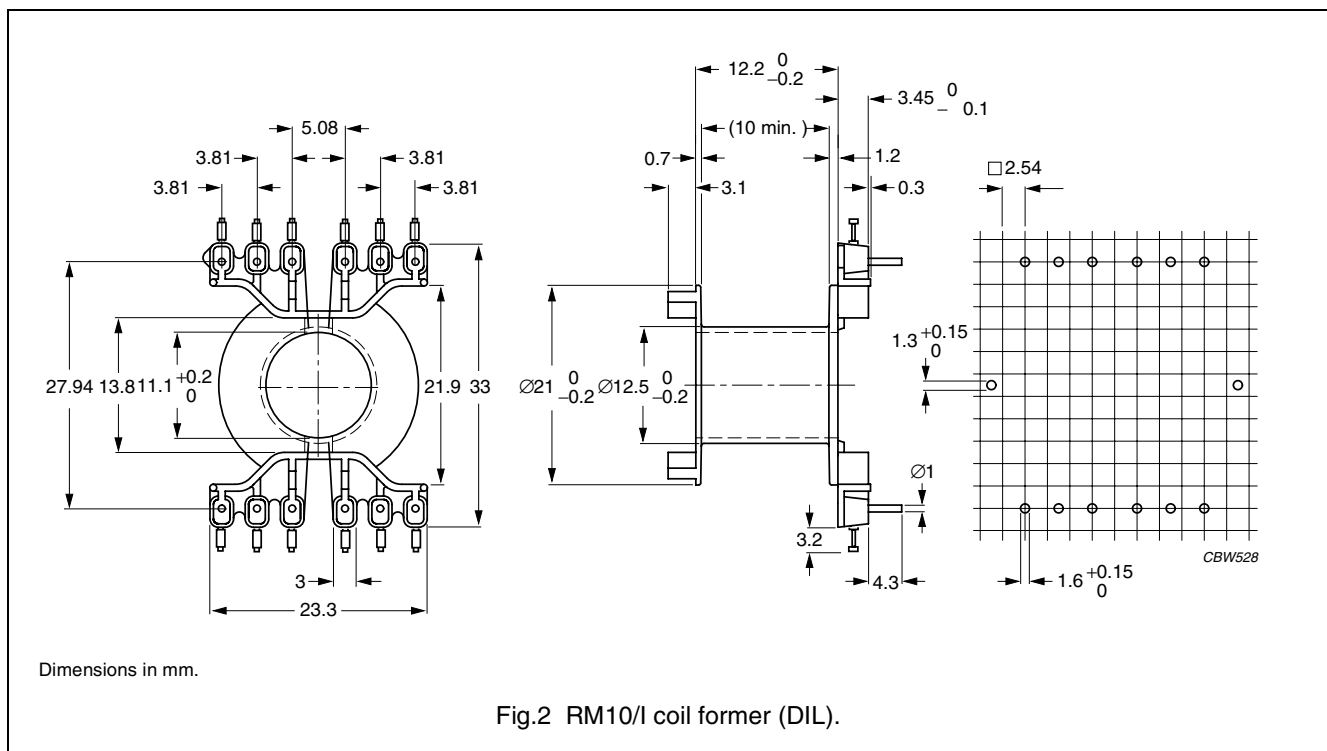

Fig.2 RM10/I coil former (DIL).

Winding data and area product for RM10 coil former (DIL)

NUMBER OF SECTIONS	AVERAGE LENGTH OF TURN (mm)	WINDING AREA (mm ²)	WINDING WIDTH (mm)	AREA PRODUCT Ae x Aw (mm ⁴)	TYPE NUMBER
1	52	44.2	10.0	4270	CPV-RM10-1S-12PD

COIL FORMER

General data

PARAMETER	SPECIFICATION
Coil former material	polyester (UP), glass-reinforced, flame retardant in accordance with "UL 94V-0"; UL file number E61040(M)
Pin material	copper-tin alloy (CuSn), tin (Sn) plated
Maximum operating temperature	180 °C, "IEC 60085", class H
Resistance to soldering heat	"IEC 60068-2-20", Part 2, Test Tb, method 1B, 350 °C, 3.5 s
Solderability	"IEC 60068-2-20", Part 2, Test Ta, method 1

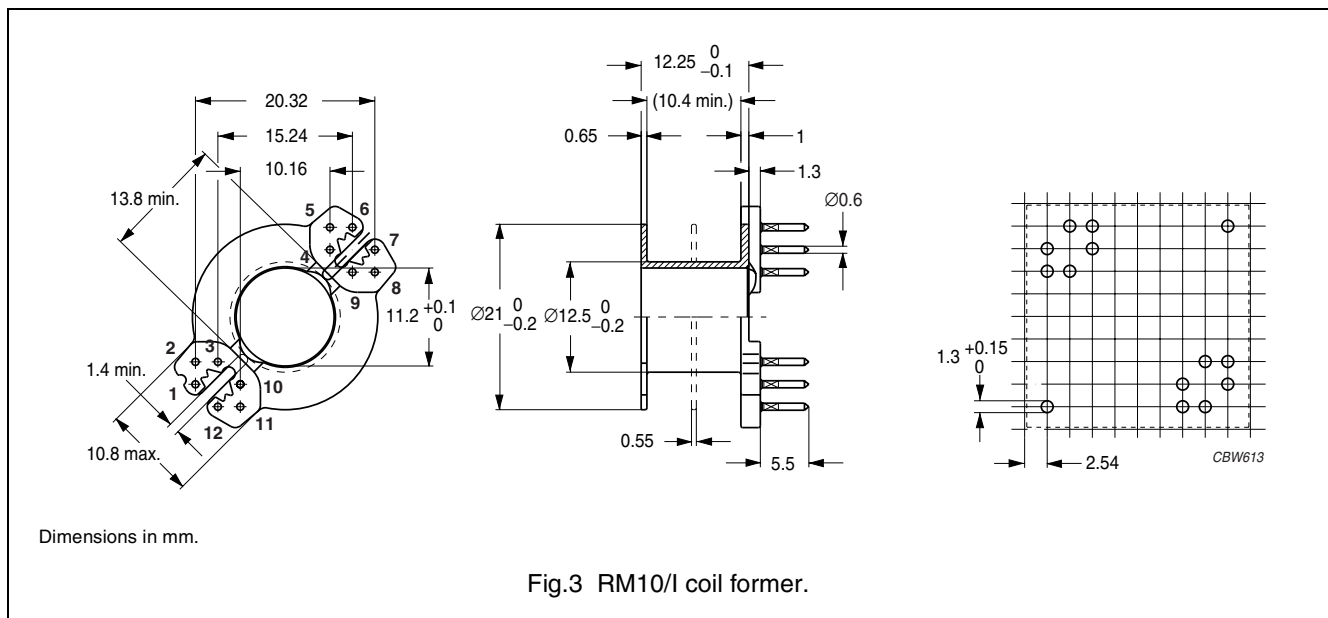

Winding data and area product for RM10/I coil former

NUMBER OF SECTIONS	NUMBER OF PINS	PIN POSITIONS USED	AVERAGE LENGTH OF TURN (mm)	WINDING AREA (mm ²)	WINDING WIDTH (mm)	AREA PRODUCT Ae x Aw (mm ⁴)	TYPE NUMBER
1	12	all	52.3	42.7	10.3	4120	CSV-RM10-1S-12P
1	5	3, 4, 6, 9, 10	52.3	42.7	10.3	4120	CSV-RM10-1S-5P
1	8	1,3,4,6,7,9, 10,12	52.3	42.7	10.3	4120	CSV-RM10-1S-8P
1	10	all exsept 2, 11	52.3	42.7	10.3	4120	CSV-RM10-1S-10P
1	11	all exsept 9	52.3	42.7	10.3	4120	CSV-RM10-1S-11P
2	8	1,3,4,6,7,9, 10,12	52.3	2 x 21.1	2 x 4.9	2 x 2040	CSV-RM10-2S-8P

NUMBER OF SECTIONS	NUMBER OF PINS	PIN POSITIONS USED	AVERAGE LENGTH OF TURN (mm)	WINDING AREA (mm ²)	WINDING WIDTH (mm)	AREA PRODUCT Ae x Aw (mm ⁴)	TYPE NUMBER
2	10	all except 2, 11	52.3	2 x 21.1	2 x 4.9	2 x 2040	CSV-RM10-2S-10P
2	12	all	52.3	2 x 21.1	2 x 4.9	2 x 2040	CSV-RM10-2S-12P
2	5	3, 4, 6, 9, 10	52.3	2 x 21.1	2 x 4.9	2 x 2040	CSV-RM10-2S-5P

MOUNTING PARTS

General data

ITEM	SPECIFICATION
Clamping force	≈30 N
Clip material	stainless steel
Clip plating	tin (Sn)
Solderability	"IEC 60068-2-20", Part 2, Test Ta, method 1
Type number	CLI/P-RM10/I

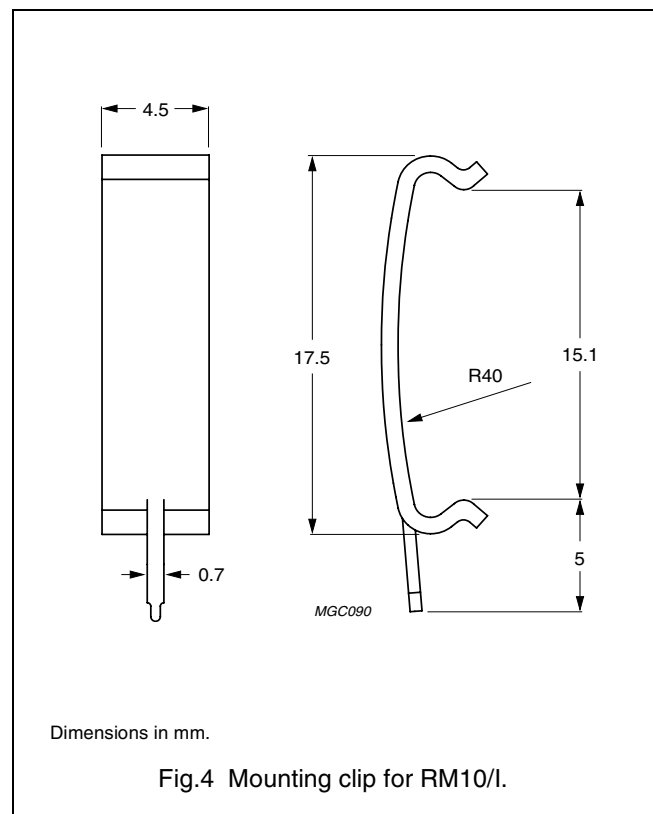



DATA SHEET STATUS DEFINITIONS

DATA SHEET STATUS	PRODUCT STATUS	DEFINITIONS
Preliminary specification	Development	This data sheet contains preliminary data. Ferroxcube reserves the right to make changes at any time without notice in order to improve design and supply the best possible product.
Product specification	Production	This data sheet contains final specifications. Ferroxcube reserves the right to make changes at any time without notice in order to improve design and supply the best possible product.

DISCLAIMER

Life support applications — These products are not designed for use in life support appliances, devices, or systems where malfunction of these products can reasonably be expected to result in personal injury. Ferroxcube customers using or selling these products for use in such applications do so at their own risk and agree to fully indemnify Ferroxcube for any damages resulting from such application.

PRODUCT STATUS DEFINITIONS

STATUS	INDICATION	DEFINITION
Prototype		These are products that have been made as development samples for the purposes of technical evaluation only. The data for these types is provisional and is subject to change.
Design-in		These products are recommended for new designs.
Preferred		These products are recommended for use in current designs and are available via our sales channels.
Support		These products are not recommended for new designs and may not be available through all of our sales channels. Customers are advised to check for availability.