

Table of Contents

1 Features	1	8.3 Feature Description.....	12
2 Applications	1	8.4 Device Functional Modes.....	15
3 Description	1	9 Application and Implementation	18
4 Revision History	2	9.1 Application Information.....	18
5 Device Comparison Table	4	9.2 Typical Application	18
6 Pin Configuration and Functions	5	10 Power Supply Recommendations	22
7 Specifications	6	11 Layout	22
7.1 Absolute Maximum Ratings	6	11.1 Layout Guidelines	22
7.2 ESD Ratings.....	6	11.2 Layout Example	22
7.3 Recommended Operating Conditions.....	6	12 Device and Documentation Support	23
7.4 Thermal Information	6	12.1 Receiving Notification of Documentation Updates	23
7.5 Electrical Characteristics.....	7	12.2 Community Resources.....	23
7.6 Typical Characteristics	9	12.3 Trademarks	23
8 Detailed Description	10	12.4 Electrostatic Discharge Caution.....	23
8.1 Overview	10	12.5 Glossary	23
8.2 Functional Block Diagram	11	13 Mechanical, Packaging, and Orderable Information	23

4 Revision History

NOTE: Page numbers for previous revisions may differ from page numbers in the current version.

Changes from Revision F (May 2019) to Revision G Page

- Added the BQ296223 and BQ296224 devices to the [Device Comparison Table](#)..... 4

Changes from Revision E (June 2018) to Revision F Page

- Added the BQ296215 device to the [Device Comparison Table](#) 4

Changes from Revision D (January 2017) to Revision E Page

- Changed [Description](#)..... 1
- Added the BQ296221 device to the [Device Comparison Table](#)..... 4
- Changed [Regulated Supply Output, REG](#)

Changes from Revision C (October 2016) to Revision D Page

- Changed device label from "BQ2960xy" to "BQ2960" and changed device label from "BQ2961xy" to "BQ2961/BQ2962" in the [Simplified Schematic](#)

- Added [Receiving Notification of Documentation Updates](#) section 23

Changes from Revision B (May 2016) to Revision C **Page**

- Added BQ2962 REG options 1
- Changed Part number to BQ2960, BQ2961, BQ2962 to identify each spin family throughout the data sheet 1
- Added BQ296202, BQ296203, BQ296212, BQ296213 4
- Added BQ2962 pinout 5
- Added bq2962 device to [Recommended Operating Conditions](#) 6
- Extended bq2962 V_{REG} full range condition from 0 mA to 2 mA, was 0 mA to 1 mA before 8
- Added BQ2962 regulator programmable option 10
- Changed figure title to apply to BQ2962 family 19
- Changed figure title to apply to BQ2962 22

Changes from Revision A (January 2016) to Revision B **Page**

- Added BQ296114 to the [Device Comparison Table](#) 4

Changes from Original (November 2013) to Revision A **Page**

- Changed the device listing in the data sheet header information to: BQ2961 1
- Changed BQ296106, '107, '111 From: Preview To: Released status 4
- Added BQ296112 to the [Device Comparison Table](#) 4
- Added BQ296113 to the [Device Comparison Table](#) 4
- Added the BQ2961xy configuration range to the [Device Comparison Table](#)..... 4

5 Device Comparison Table

Table 1. BQ2961 Device Options

BQ2961	OVP (V)	OVP DELAY (s)	UV (V)	LDO (V)
BQ296100	4.35	6.5	2.5	3.3
BQ296103	4.50	6.5	2.5	3.3
BQ296106	4.45	6.5	2.8	3.3
BQ296107	4.50	6.5	2.8	3.3
BQ296111	4.45	4.0	2.5	3.3
BQ296112	4.50	3.0	2.5	3.3
BQ296113	4.35	3.0	2.5	3.3
BQ296114	4.50	4.0	2.5	3.3
BQ2961	3.85 V–4.60 V (50-mV step)	3.0, 4.0, 5.5, 6.5	2.0 V–2.8 V (50-mV step)	1.8, 2.5, 3.3

Table 2. BQ2962 Device Options

BQ2962	OVP (V)	OVP DELAY (s)	UV (V)	LDO (V)
BQ296202	4.45	6.5	2.5	3.3
BQ296203	4.50	6.5	2.5	3.3
BQ296212	4.50	3.0	2.5	3.3
BQ296213	4.35	3.0	2.5	3.3
BQ296215 ⁽¹⁾	4.50	6.5	2.5	3.0
BQ296216	4.55	6.5	2.5	3.0
BQ296217	4.55	6.5	2.8	3.3
BQ296221 ⁽¹⁾	4.55	6.5	2.5	3.3
BQ296223	4.50	6.5	2.5	3.3
BQ296224	4.50	6.5	2.5	3.0
BQ2962	3.85 V–4.60 V (50-mV step)	3.0, 4.0, 5.5, 6.5	2.0 V–2.8 V (50-mV step)	3, 3.15, 3.3

(1) Contact TI for more information.

6 Pin Configuration and Functions

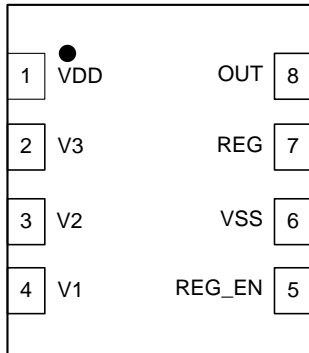
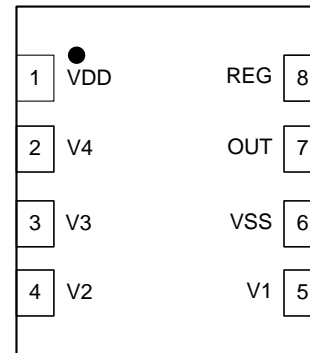
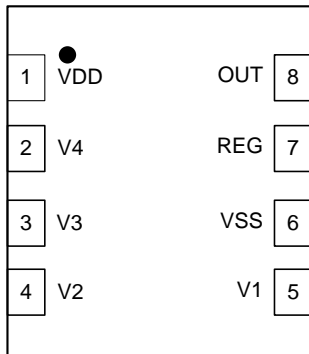
**2-Series to 3-Series BQ2960
(Top View)**

**2-Series to 4-Series BQ2962
(Top View)**

**2-Series to 4-Series BQ2961
(Top View)**

Pin Functions

NAME	PIN			TYPE ⁽¹⁾	DESCRIPTION
	BQ2960	BQ2961	BQ2962		
OUT	8	8	7	OA	Analog output drive for an overvoltage fault signal; CMOS output high or open-drain active low
PWPD	9	9	9	P	TI recommends connecting the exposed pad to VSS on PCB.
REG	7	7	8	OA	Regulated supply output. Requires an external ceramic capacitor for stability
REG_EN	5	—	—	IA	Regulated supply output enable. A "high" to enable REG output and "low" to disable REG output
V1	4	5	5	IA	Sense input for positive voltage of the lowest cell from the bottom of the stack
V2	3	4	4	IA	Sense input for positive voltage of the second cell from the bottom of the stack
V3	2	3	3	IA	Sense input for positive voltage of the third cell from the bottom of the stack
V4	—	2	2	IA	Sense input for positive voltage of the fourth cell from the bottom of the stack
VDD	1	1	1	P	Power supply input
VSS	6	6	6	P	Electrically connected to integrated circuit ground and negative terminal of the lowest cell in the stack

(1) IA = Analog input, OA = Analog Output, P = Power connection

7 Specifications

7.1 Absolute Maximum Ratings

Over operating free-air temperature range (unless otherwise noted)⁽¹⁾

		MIN	MAX	UNIT
Supply voltage	VDD – VSS	–0.3	30	V
Input voltage	V4 – V3, V3 – V2, V2 – V1, V1 – VSS	–0.3	30	
	REG – VSS	–0.3	3.6	
	REG_EN – VSS	–0.3	28	
Output voltage	OUT – VSS	–0.3	30	
Continuous total power dissipation, P _{TOT}		See Thermal Information .		
Lead temperature (soldering, 10 s), T _{SOLDER}		300	300	°C
Storage temperature, T _{stg}		–65	150	°C

- (1) Stresses beyond those listed under *Absolute Maximum Ratings* may cause permanent damage to the device. These are stress ratings only, which do not imply functional operation of the device at these or any other conditions beyond those indicated under *Recommended Operating Procedures*. Exposure to absolute-maximum-rated conditions for extended periods may affect device reliability.

7.2 ESD Ratings

		VALUE	UNIT
V _(ESD) Electrostatic discharge	Human body model (HBM), per ANSI/ESDA/JEDEC JS-001 ⁽¹⁾	2000	V
	Charged device model (CDM), per JEDEC specification JESD22-C101 ⁽²⁾	500	

- (1) JEDEC document JEP155 states that 500-V HBM allows safe manufacturing with a standard ESD control process.
 (2) JEDEC document JEP157 states that 250-V CDM allows safe manufacturing with a standard ESD control process.

7.3 Recommended Operating Conditions

Over operating free-air temperature range (unless otherwise noted).

		MIN	NOM	MAX	UNIT
Supply voltage, V _{DD} ⁽¹⁾	Supply voltage, V _{DD} ⁽¹⁾ , bq2960	3		15	V
	Supply voltage, V _{DD} ⁽¹⁾ , bq2961, bq2962	3		20	
	Supply voltage, V _{DD} with REG output on	4			
Input voltage range	V _n – V _{n-1} , V1 – VSS	0		5	V
	REG_EN	0		15	V
Operating ambient temperature range, T _A		–40		110	°C

- (1) See [Typical Application](#).

7.4 Thermal Information

THERMAL METRIC ⁽¹⁾		bq296xxx	UNIT
		DSG (WSON)	
		8 PINS	
R _{θJA}	Junction-to-ambient thermal resistance	62	°C/W
R _{θJC(top)}	Junction-to-case(top) thermal resistance	72	°C/W
R _{θJB}	Junction-to-board thermal resistance	32.5	°C/W
ψ _{JT}	Junction-to-top characterization parameter	1.6	°C/W
ψ _{JB}	Junction-to-board characterization parameter	33	°C/W
R _{θJC(bot)}	Junction-to-case(bottom) thermal resistance	10	°C/W

- (1) For more information about traditional and new thermal metrics, see the [Semiconductor and IC Package Thermal Metrics](#) application report.

7.5 Electrical Characteristics

Typical values stated where $T_A = 25^\circ\text{C}$ and $V_{DD} = 14.4\text{ V}$, MIN/MAX values stated where $T_A = -40^\circ\text{C}$ to $+110^\circ\text{C}$, and $V_{DD} = 3\text{ V}$ to 15 V (unless otherwise noted).

PARAMETER		TEST CONDITIONS	MIN	TYP	MAX	UNIT
Voltage Protection Thresholds						
V_{OV}	$V_{(PROTECT)}$ Overvoltage Detection	$R_{IN} = 1\text{ k}\Omega$	Applicable Voltage: 3.85 V to 4.6 V in 50-mV steps			V
V_{HYS}	OV Detection Hysteresis		250	300	400	mV
V_{OA}	OV Detection Accuracy	$T_A = 25^\circ\text{C}$	-10		10	mV
$V_{OADRIFT}$	OV Detection Accuracy Across Temperature	$T_A = -40^\circ\text{C}$	-40		40	mV
		$T_A = 0^\circ\text{C}$	-20		20	mV
		$T_A = 60^\circ\text{C}$	-24		24	mV
		$T_A = 110^\circ\text{C}$	-54		54	mV
		$T_A = 110^\circ\text{C}$	-54		54	mV
Supply and Leakage Current						
I_{DD}	Supply Current with REG on	$(V_n - V_{n-1}) = 2\text{ V}$ to 4.15 V , $n = 1$ to 4 , $V_{DD} = \text{top } V_n \text{ voltage}$ $(V1 - V_{SS}) > V_{UVREG}$, $I_{REG} = 0\text{ mA}$,	$T_A = 0^\circ\text{C}$ to 60°C	4	6	μA
			$T_A = -40^\circ\text{C}$ to 110°C		8	μA
I_{DD}	Supply Current with REG off	$(V_n - V_{n-1}) = 2\text{ V}$ to 4.15 V , $n = 1$ to 4 , $V_{DD} = \text{top } V_n \text{ voltage}$ $(V1 - V_{SS}) < V_{UVREG}$	$T_A = 0^\circ\text{C}$ to 60°C	1	2	μA
			$T_A = -40^\circ\text{C}$ to 110°C		4	μA
I_{IN}	Input Current at V_x Pins	$(V_n - V_{n-1}) = (V1 - V_{SS}) = 3.8\text{ V}$, $V_{DD} = \text{top } V_n \text{ voltage}$, $T_A = 25^\circ\text{C}$	-0.1		0.1	μA
Output Drive OUT, CMOS Active High						
V_{OUT}	Output Drive Voltage, Active High	$(V_n - V_{n-1})$ or $(V1 - V_{SS}) > V_{OV}$, $I_{OH} = 100\text{ }\mu\text{A}$, $V_{DD} = \text{top } V_n$ voltage	6	7	8	V
		If three of four cells are short circuited, only one cell remains powered and $> V_{OV}$, $V_{DD} = V_n$ (the remaining cell voltage), $I_{OH} = 100\text{ }\mu\text{A}$		$V_{DD} - 0.3$		V
		$(V_n - V_{n-1})$ and $(V1 - V_{SS}) < V_{OV}$, $V_{DD} = \text{sum of the cell stack}$ voltage, $I_{OL} = 100\text{ }\mu\text{A}$ measured into OUT pin		250	400	mV
I_{OUTH}	OUT Source Current (during OV)	$(V_n - V_{n-1})$, $(V3 - V2)$, or $(V1 - V_{SS}) > V_{OV}$, $V_{DD} = \text{top } V_n$ voltage, forced OUT = 0 V, measured out of OUT pin			4.5	mA
I_{OUTL}	OUT Sink Current (no OV)	$(V_n - V_{n-1})$ and $(V1 - V_{SS}) < V_{OV}$, $V_{DD} = \text{top } V_n \text{ voltage}$, forced OUT = VDD, measured into OUT pin. Pull-up resistor $R_{PU} = 5\text{ k}\Omega$ to VDD	0.5		14	mA
Internal Fixed Delay Timer						
t_{DELAY}	OV Delay Time ⁽¹⁾	Internal Fixed Delay, 3-s delay option	2.4	3	3.6	s
		Internal Fixed Delay, 4-s delay option	3.2	4	4.8	s
		Internal Fixed Delay, 5.5-s delay option	4.4	5.5	6.6	s
		Internal Fixed Delay, 6.5-s delay option	5.2	6.5	7.8	s
t_{DELAY_CTM}	Fault Detection Delay Time in Test Mode OV Delay Time	Internal Fixed delay		15		ms

(1) Specified by design. Not 100% tested in production.

Electrical Characteristics (continued)

Typical values stated where $T_A = 25^\circ\text{C}$ and $V_{DD} = 14.4\text{ V}$, MIN/MAX values stated where $T_A = -40^\circ\text{C}$ to $+110^\circ\text{C}$, and $V_{DD} = 3\text{ V}$ to 15 V (unless otherwise noted).

PARAMETER	TEST CONDITIONS	MIN	TYP	MAX	UNIT		
Regulated Supply Output, REG							
V_{REG}	REG Supply at 500 μA load	$V_{DD} \geq 4\text{ V}$, $I_{REG} = 500\ \mu\text{A}$, $C_{REG} = 0.47\ \mu\text{F}$	$V_{REG} = 3.3\text{ V}$, bq2960, bq2961, bq2962	3.234	3.300	3.366	V
			$V_{REG} = 3.15\text{ V}$, bq2962	3.087	3.150	3.213	
			$V_{REG} = 3.0\text{ V}$, bq2962	2.940	3.000	3.060	
			$V_{REG} = 2.5\text{ V}$, bq2960, bq2961	2.450	2.500	2.550	
			$V_{REG} = 1.8\text{ V}$, bq2960, bq2961	1.764	1.800	1.836	
V_{REG}	REG Supply from 0 to 2 mA load	$V_{DD} \geq 4\text{ V}$, $I_{REG} = 0\ \mu\text{A}$ to 2 mA, $C_{REG} = 0.47\ \mu\text{F}$	$V_{REG} = 3.3\text{ V}$, bq2960, bq2961, bq2962	3.200	3.300	3.400	V
			$V_{REG} = 3.15\text{ V}$, bq2962	3.050	3.150	3.250	
			$V_{REG} = 3.0\text{ V}$, bq2962	2.900	3.000	3.100	
			$V_{REG} = 2.5\text{ V}$, bq2960, bq2961	2.425	2.500	2.575	
			$V_{REG} = 1.8\text{ V}$, bq2960, bq2961	1.746	1.800	1.854	
I_{REG}	REG Current Output	$V_{DD} \geq 4\text{ V}$, $C_{REG} = 0.47\ \mu\text{F}$	0		2	mA	
$I_{REG_SC_Limit}$	REG Output Short Circuit Current Limit	$REG = V_{SS}$, $C_{REG} = 0.47\ \mu\text{F}$	4			mA	
R_{REG_PD}	REG pull-down resistor	REG is disabled.	20	30	45	k Ω	
Regulated Supply Output Enable, REG_EN							
V_{IH}	High-level Input		1.6			V	
V_{IL}	Low-level Input				0.4	V	
I_{LKG}	Input Leakage Current	$V_{IH} < 6\text{ V}$			0.1	μA	
Regulated Supply Undervoltage Self-Disable							
V_{UVREG}	Undervoltage detection	Factory Configuration: 2.0 V to 2.8 V in 50 mV steps, $T_A = 25^\circ\text{C}$	-50		50	mV	
V_{UVHYS}	Undervoltage Detection Hysteresis		250	300	400	mV	
$t_{UVDELAY}$	Undervoltage Detection Delay		4.5	6	7.5	s	
V_{UVQUAL}	Cell voltage to qualify for UV detection			0.5		V	

7.6 Typical Characteristics

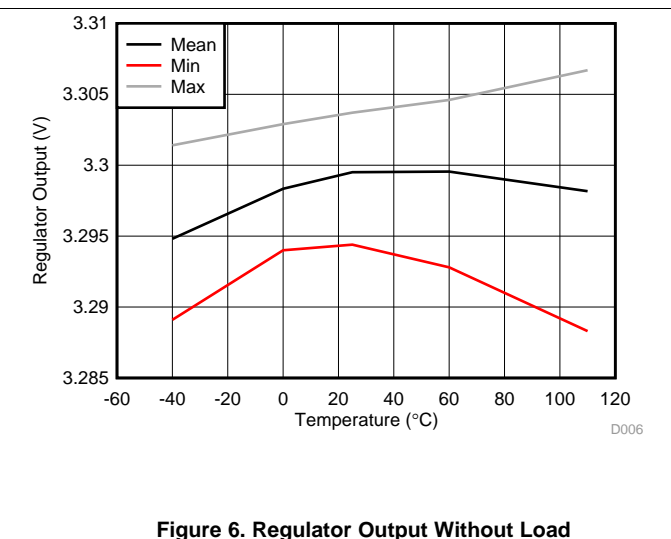
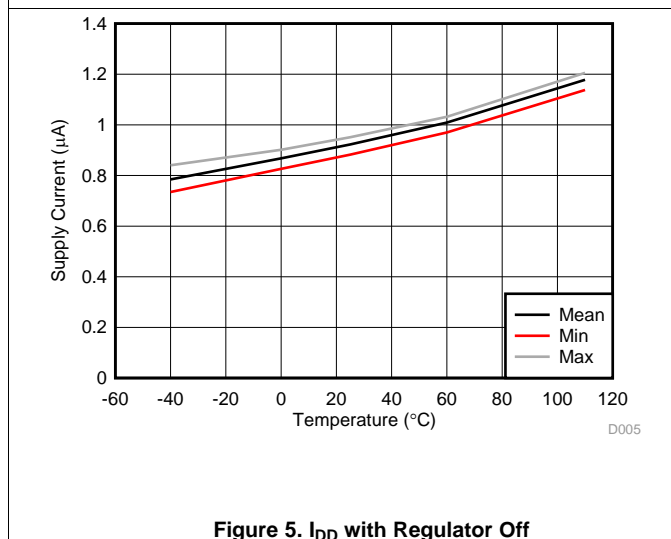
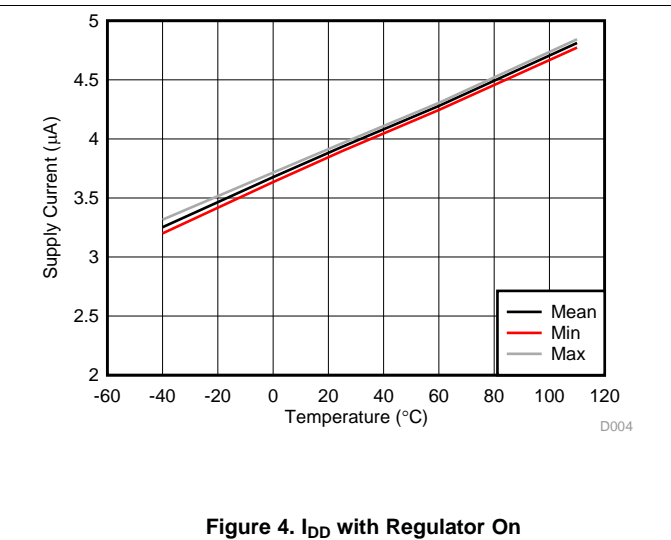
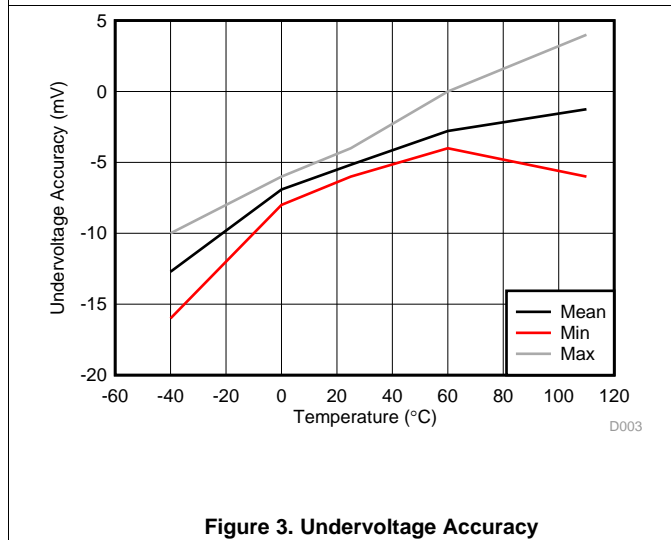
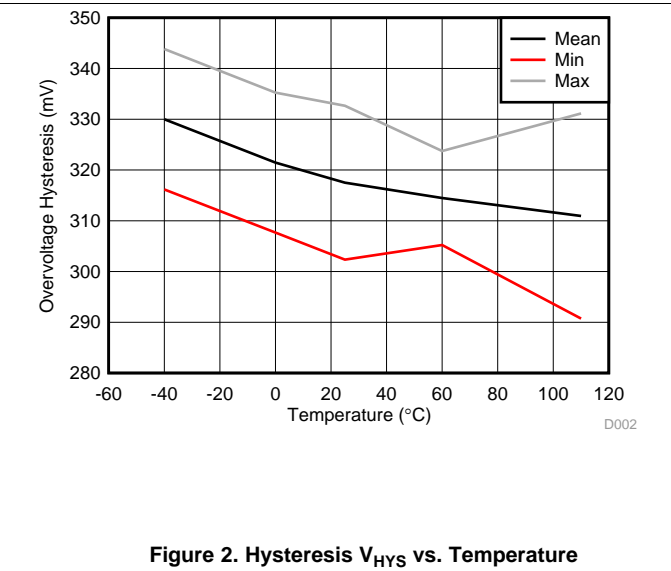
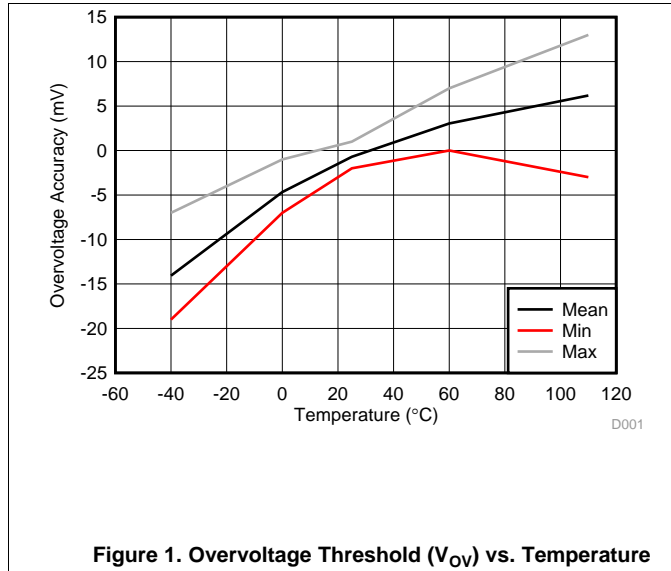

Typical Characteristics (continued)

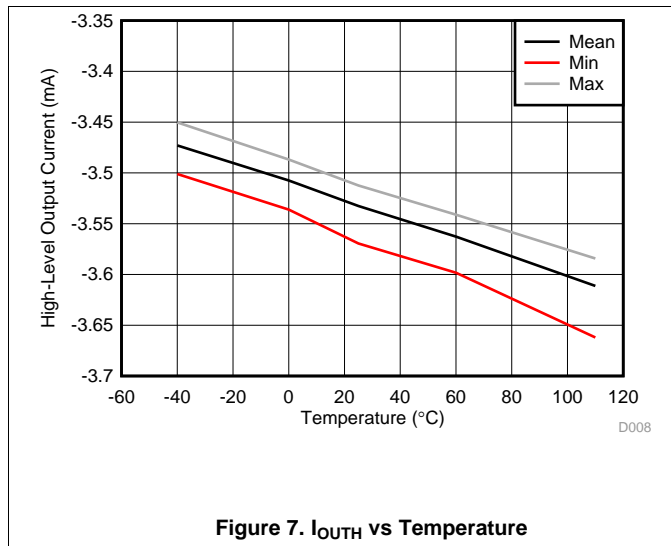

Figure 7. I_{OUTH} vs Temperature

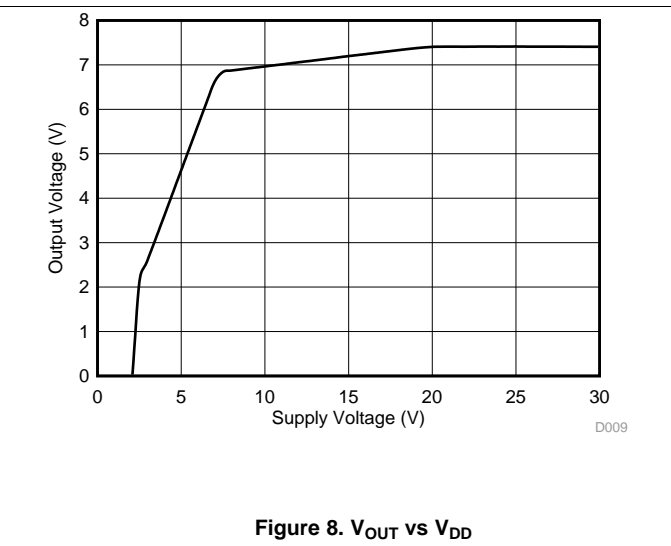

Figure 8. V_{OUT} vs V_{DD}

8 Detailed Description

8.1 Overview

The BQ2960, BQ2961, and BQ2962 are second-level overvoltage (OV) protectors with a regulated output. Each cell is monitored independently by comparing the actual cell voltage to an overvoltage threshold V_{OV} . The overvoltage threshold is preprogrammed at the factory with a range between 3.85 V to 4.65 V.

The regulated output is enabled unless any of the cell voltages fall below the V_{UVREG} threshold. This threshold is preprogrammed at the factory with a range between 2 V to 2.8 V. For BQ2960xy family, an external control pin, REG_EN, is available to enable or disable the regulated output in addition to the V_{UVREG} detection.

Table 3. Programmable Parameters

OVERVOLTAGE RANGE (V)	OVERVOLTAGE DELAY (s)	UNDERVOLTAGE RANGE (V)	REGULATOR (V)
3.85 to 4.6 in 50-mV step	3, 4, 5.5, 6.5	2.0 to 2.8 in 50-mV step	1.8, 2.5, 3.3 (BQ2960, BQ2961) 3.0, 3.15, 3.3 (BQ2962)

8.2 Functional Block Diagram

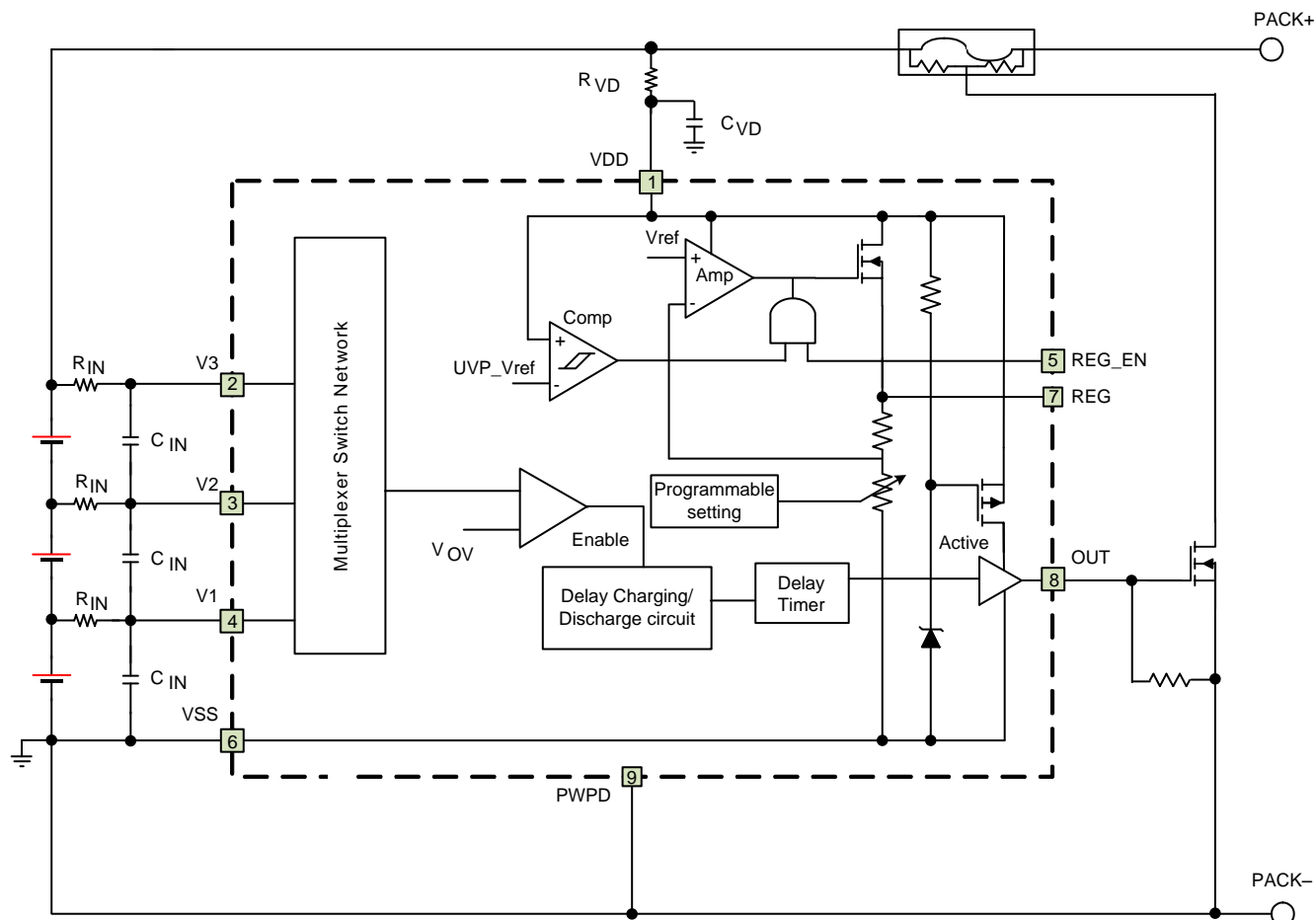
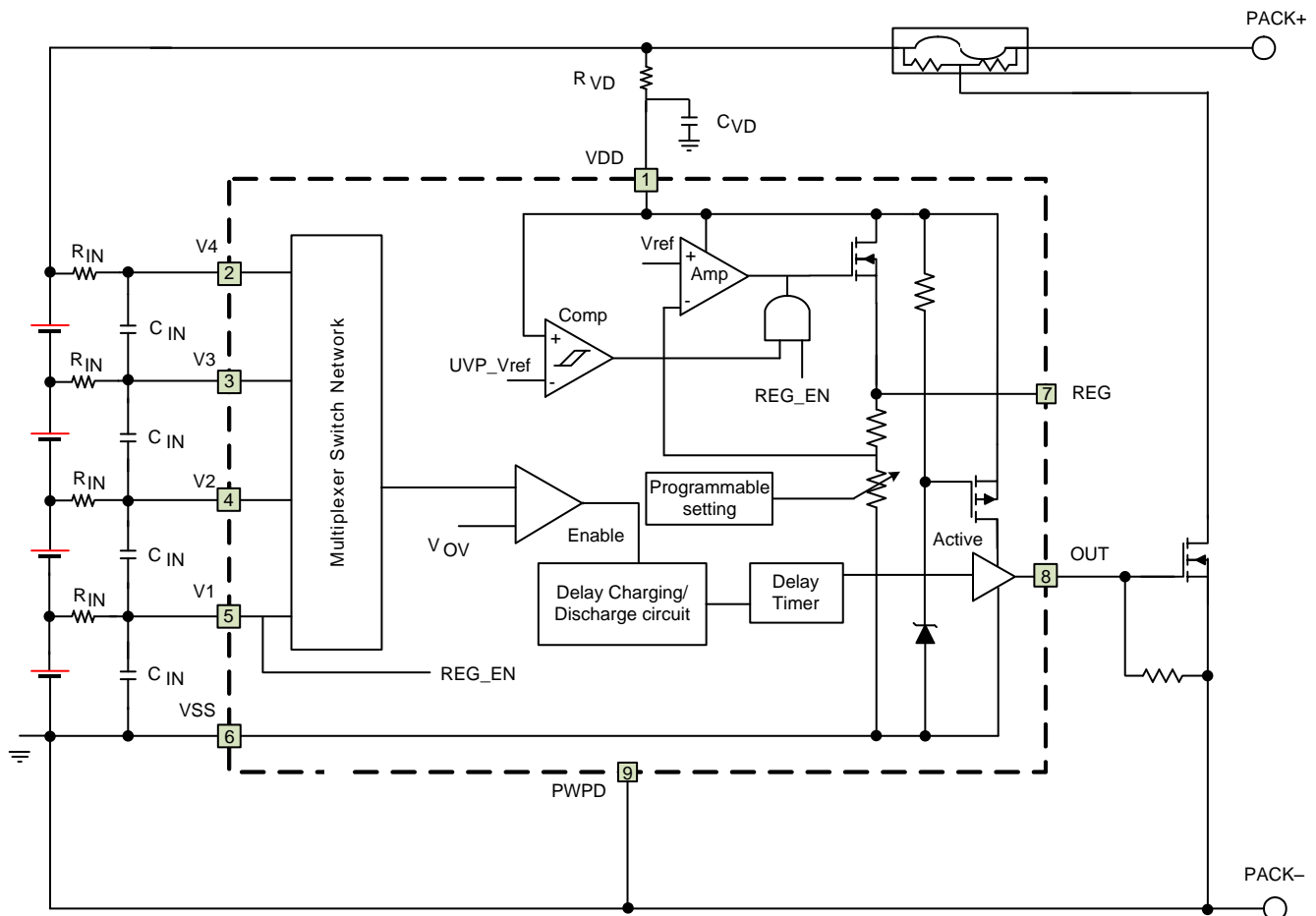

Figure 9. BQ2960 Block Diagram

Functional Block Diagram (continued)

Figure 10. BQ2961 and BQ2962 Block Diagram

8.3 Feature Description

8.3.1 Pin Details

8.3.1.1 Input Sense Voltage, V_x

These inputs sense each battery cell voltage. A series resistor and a capacitor across the cell for each input is required for noise filtering and stable voltage monitoring.

8.3.1.2 Output Drive, *OUT*

This terminal serves as the fault signal output in active high.

8.3.1.3 Supply Input, *VDD*

This terminal is the unregulated input power source for the device. A series resistor is connected to limit the current, and a capacitor is connected to ground for noise filtering.

8.3.1.4 Regulated Supply Output, *REG*

This terminal is connected to an external capacitor and provides a regulated supply to power a circuit such as a real-time clock integrated circuit, or functions requiring a well-regulated supply. Maximum current load on this pin cannot exceed I_{REG} mA.

Feature Description (continued)

The REG output has protection for overcurrent, using a current limit protection circuit, and also detects and protects for excessive power dissipation due to short circuit of the external load. This pin requires a ceramic 1- μ F capacitor connection to VSS for improved stability, noise immunity, and ESD performance of the supply output. This capacitor must be placed close to the REG and VSS pins for connection.

8.3.1.5 Regulated Supply Output Enable, REG_EN (BQ2960 Only)

This terminal is a high-voltage input drain to enable and disable the regulated supply output, REG terminal. When the VREG_EN > V_{IH} , the REG terminal output is enabled including the cell undervoltage detection function to self-disable the regulated supply. When the VREG_EN < V_{IL} , the REG terminal output, the cell undervoltage detection and the regulated supply self-disable functions are disabled.

To keep the REG output enabled at all times, the recommendation is to connect the REG_EN to the V1 termination. There is a 6-V clamp to protect the REG_EN terminal from a high voltage input. By connecting REG_EN to V1, the clamp circuit is not active.

When the REG output is enabled, VREG_EN > V_{IH} , the REG output can be self-disabled if any of the cell voltages are < V_{UVREG} . The self-disable function is used to reduce power consumption when the battery pack is deeply depleted.

8.3.2 Overvoltage Sensing for OUT

In the BQ296xxx device, each cell is monitored independently. Overvoltage is detected by comparing the actual cell voltage to a protection voltage reference, V_{OV} . If any cell voltage exceeds the programmed OV value, an internal timer circuit is activated. This timer circuit causes a factory pre-programmed fixed delay before the OUT terminal goes from inactive to active state.

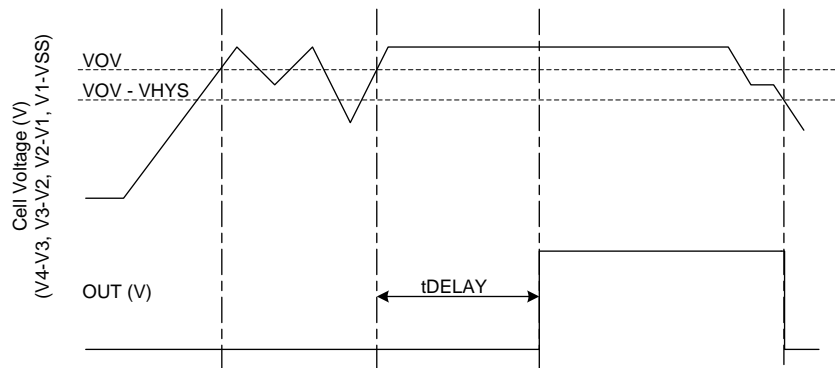

Figure 11. Timing for Overvoltage Sensing for OUT

8.3.3 Regulated Output Voltage and REG_EN Pin

For BQ2960 and BQ2961, there are three factory-preprogrammed options for the regulated output voltage, 3.3 V, 2.5 V, and 1.8 V. For BQ2962, the regulated output voltage options are 3.3 V, 3.15 V, and 3.0 V. Potentially, the BQ2962xy device can provide other regulated voltage output between 3.3 V to 3.0 V. Contact Texas Instruments for details.

At power up, the regulated output is on by default. If any cell voltage is below V_{UVREG} at device power up, the regulated output will remain on until the t_{UV_DELAY} time has passed, the regulated output turns off after the delay time.

During discharge, if any cell voltage falls below the V_{UVREG} threshold for t_{UV_DELAY} time, the regulated output is self-disabled. The regulated output turns on again when all the cell voltages are above $V_{UVREG} + V_{UVHYS}$.

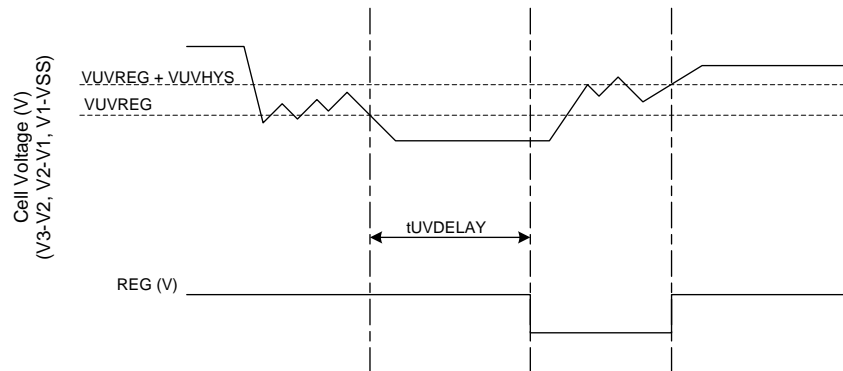
Feature Description (continued)

Figure 12. REG Output Timing

For the BQ2960 family, an external REG_EN pin is available to enable and disable the regulated output function. To enable both the regulated output and the undervoltage self-disable features, the REG_EN pin must be above V_{IH} . A microcontroller can be used to control the REG_EN pin. Alternatively, connecting the REG_EN pin to the bottom cell is another option to enable the regulated output function always.

Feature Description (continued)

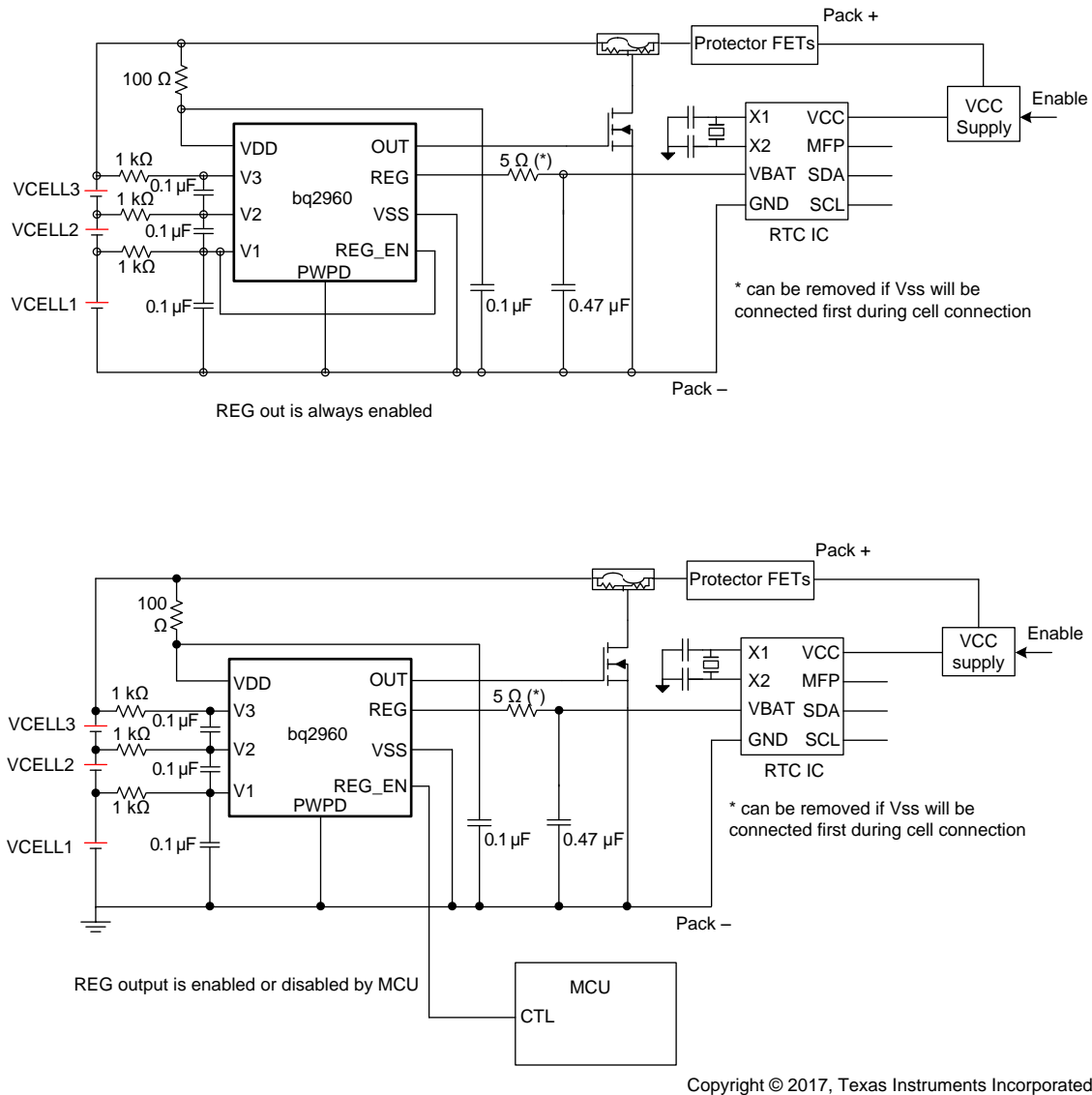

Figure 13. BQ2960 Application Schematic

8.4 Device Functional Modes

8.4.1 NORMAL Mode

When all of the cell voltages are below the V_{OV} threshold AND above V_{UVREG} threshold, the device operates in NORMAL mode. The device monitors the differential cell voltages connected across (V1–VSS), (V2–V1), (V3–V2), and (V4–V3). The OUT pin is inactive in this mode. The regulated output is always enabled for BQ2961. For BQ2960, the regulated output is on only if the voltage on the REG_EN pin is above V_{IH} .

Device Functional Modes (continued)

8.4.2 OVERVOLTAGE Mode

OVERVOLTAGE mode is detected if any of the cell voltages exceed the overvoltage threshold, V_{OV} , for a configured OV delay time. The OUT pin is activated after a delay time preprogrammed at the factory. The OUT pin will pull high internally. Then an external FET is turned on, shorting the fuse to ground, which allows the battery and/or charger power to blow the fuse. When all of the cell voltages fall below $(V_{OV} - V_{HYS})$, the device returns to NORMAL mode. The regulated output (if enabled) remains on in this mode.

8.4.3 UNDERVOLTAGE Mode

The UNDERVOLTAGE mode is detected if any of the cell voltage across $(V1-VSS)$, $(V2-V1)$, $(V3-V2)$, or $(V4-V3)$ is below the V_{UVREG} threshold for t_{UV_DELAY} time. In this mode, the regulated output is disabled. To return to the NORMAL mode, all the cell voltages must be above $(V_{UVREG} + V_{UVHYS})$.

For a low cell configuration, V_n pin can be shorted to the $(V_n - 1)$ pin. The device ignores any differential cell voltage below V_{UVQUAL} threshold for undervoltage detection.

8.4.4 CUSTOMER TEST MODE

The Customer Test Mode (CTM) helps to reduce test time for checking the overvoltage delay-timer parameter once the circuit is implemented into the battery pack. To enter CTM, the VDD pin should be set at least 10 V higher than V3 (see Figure 14). The delay timer is greater than 10 ms, but considerably shorter than the timer delay in normal operation. To exit CTM, remove the VDD to VC3 voltage differential of 10 V, so that the decrease in the value automatically causes an exit.

CAUTION

Avoid exceeding any Absolute Maximum Voltages on any pins when placing the device into CTM. Also avoid exceeding Absolute Maximum Voltages for the individual cell voltages $(V3-V2)$, $(V2-V1)$ and $(V1-VSS)$. Stressing the pins beyond the rated limits can cause permanent damage to the device.

Figure 14 shows the timing for the Customer Test Mode.

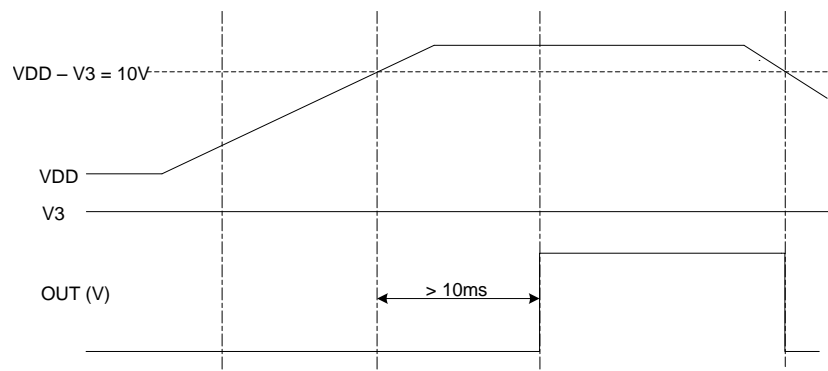

Figure 14. Timing for Customer Test Mode

Device Functional Modes (continued)

Figure 15 shows the measurement for current consumption of the product for both VDD and Vx.

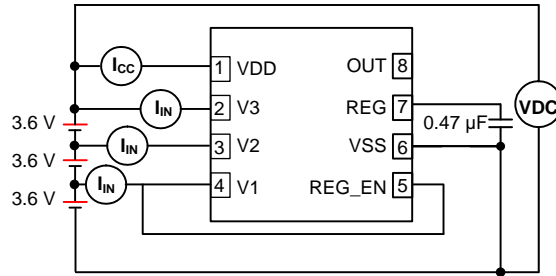

Figure 15. Configuration for Integrated Circuit Current Consumption Test

9 Application and Implementation

NOTE

Information in the following applications sections is not part of the TI component specification, and TI does not warrant its accuracy or completeness. TI's customers are responsible for determining suitability of components for their purposes. Customers should validate and test their design implementation to confirm system functionality.

9.1 Application Information

The BQ296xxx family of second-level protectors is used for overvoltage protection of the battery pack in the application. A regulated output is available to drive a small circuit with maximum I_{REG} loading. The device OUT pin is active high, which drives a NMOS FET that connects the fuse to ground in the event of a fault condition. This provides a shorted path to use the battery and/or charger power to blow the fuse and cut the power path.

9.2 Typical Application

Figure 13 shows the recommended reference design components.

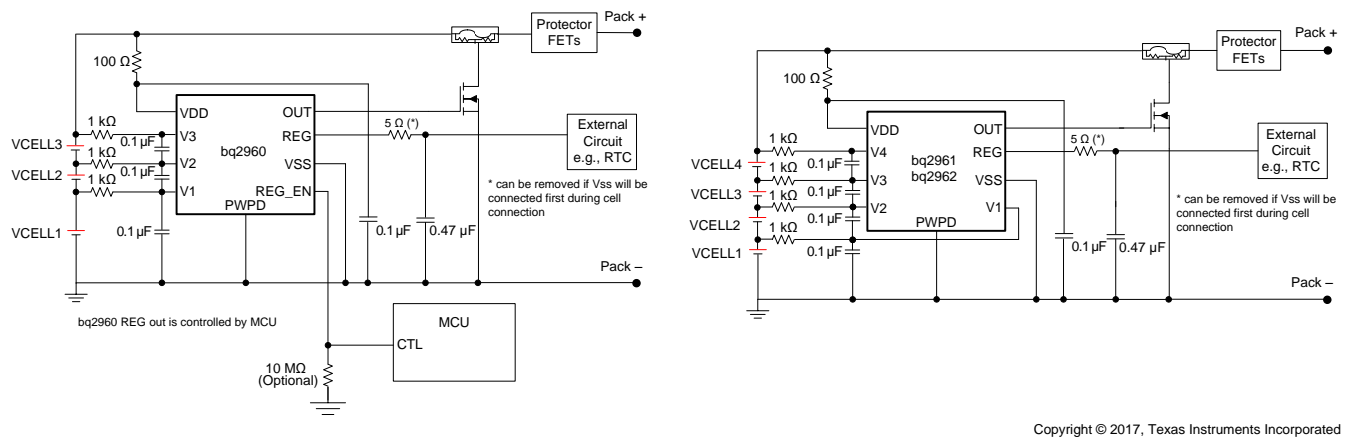

Copyright © 2017, Texas Instruments Incorporated

Figure 16. Application Schematic

9.2.1 Design Requirements

NOTE

Changes to the ranges shown in Table 4 will impact the accuracy of the cell measurements.

Table 4. Parameters

PARAMETER	EXTERNAL COMPONENT	MIN	NOM	MAX	UNIT
Voltage monitor filter resistance	R_{IN}	900	1000	4700	Ω
Voltage monitor filter capacitance	C_{IN}	0.01	0.1	1.0	μF
Supply voltage filter resistance	R_{VD}	0.1	—	1	$K\Omega$
Supply voltage filter capacitance	C_{VD}	—	0.1	1.0	μF
REG output capacitance	C_{REG}	0.47	1	—	μF

NOTE

The device is calibrated using an R_{IN} value = 1 k Ω . Using a value other than the recommended value changes the accuracy of the cell voltage measurements and V_{OV} trigger level.

9.2.2 Detailed Design Procedure

NOTE

The device VSS must be connected first during PCB test or cell attachment. Failure to do so can damage the REG pin.

1. If the VSS pin cannot be connected first, it is required to add a resistor of a minimum of 5 Ω to a maximum of 10 Ω (a 5-Ω resistor is used in the reference schematic, [Figure 17](#)) in series with the REG capacitor. When VSS is floating, the REG capacitor always charges up to the VDD voltage. When VSS is finally connected, the REG capacitor will be discharged. Adding a small resistor in series reduces the current strength and avoids any potential damage to the REG pin. The 5-Ω resistor can be placed in series with the REG connect circuit (as shown in [Figure 17](#)) or in series of the REG capacitor (as shown in [Figure 18](#)). Placing the resistor in series with the REG circuit results in a small drop of V_{REG} (for example: max loading of I_{REG} mA with a 5-Ω resistor will drop 5 mV on V_{REG}), but such a connection can protect against rush current discharge from a REG capacitor or an external filter capacitor connected to the REG pin. Placing the resistor in series with the REG capacitor is an alternative to avoiding an additional drop in V_{REG} if the filter capacitor used by the external circuit is much smaller than the REG capacitor.
2. After VSS is connected, the device allows a random cell connection to the Vx pin.
3. The cell should be connected to the lower V_n pin; the unused V_n pin should be shorted to the (V_{n-1}) pin. See [Figure 17](#) for details.

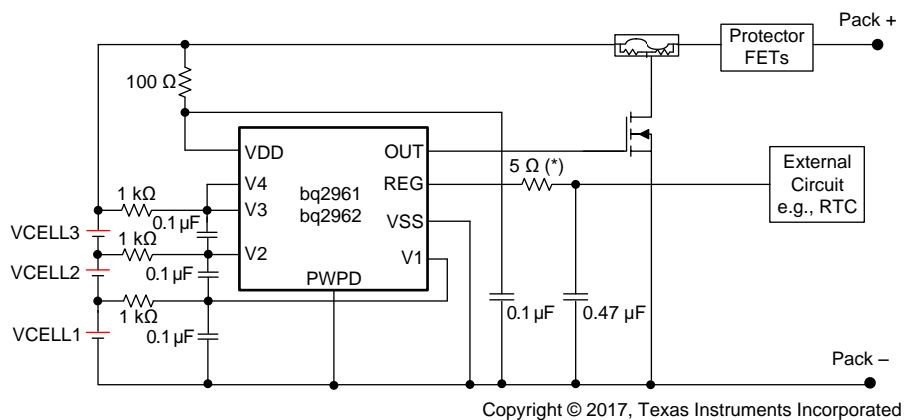

Figure 17. 3-Series BQ2961 and BQ2962 Schematic

4. A zener diode can be added to the REG pin to VSS, as shown in [Figure 18](#). This is recommended to protect the circuit connected to the REG pin if floating VSS in the field is a risk concern. When VSS is floating (during cell connection when VSS is not connected first or in a system fault with a broken BAT– wire), the REG voltage always pulls up to VDD. In a 4-series configuration, the REG voltage can reach approximately 16 V with VSS floating. Adding a zener diode clamps the REG voltage to a safe level for the external circuits connected to the REG pin. Having the zener diode can also protect the external circuits if the REG pin is shorted to the OUT pin or any other high-voltage output terminal. If a zener diode is used, TI recommends putting the diode on the battery side with the BQ296xxx device to allow protection on the REG pin, as well as the circuit connected to REG under the floating VSS condition. The resistor in series with the REG pin is not required in this case.

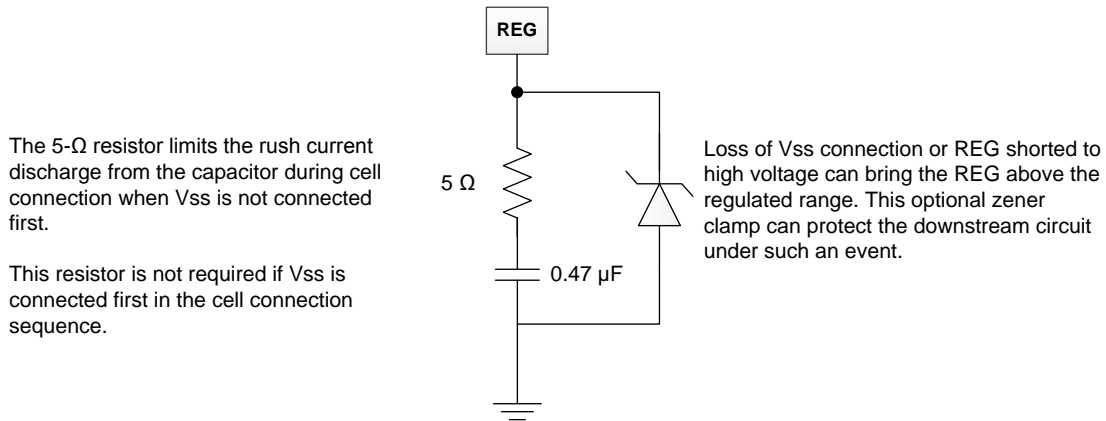

Figure 18. 5-V Zener Diode

- For 2-series to 3-series applications, if an external control for the regulated output is required, select the BQ2960xy family. Otherwise, select the BQ2961xy family.

9.2.3 Application Curves

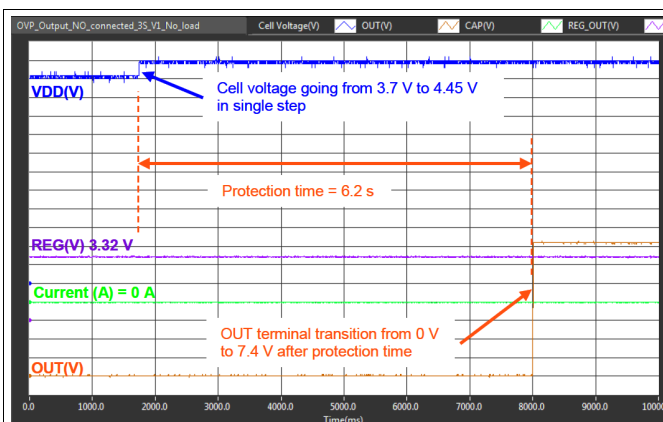

Figure 19. Overvoltage Protection

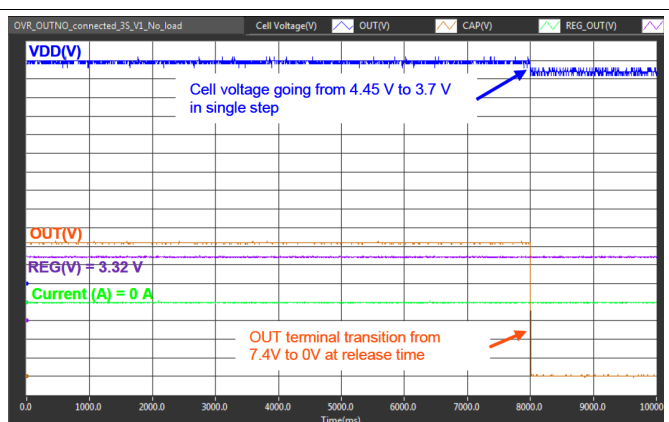

Figure 20. Overvoltage Protection Release

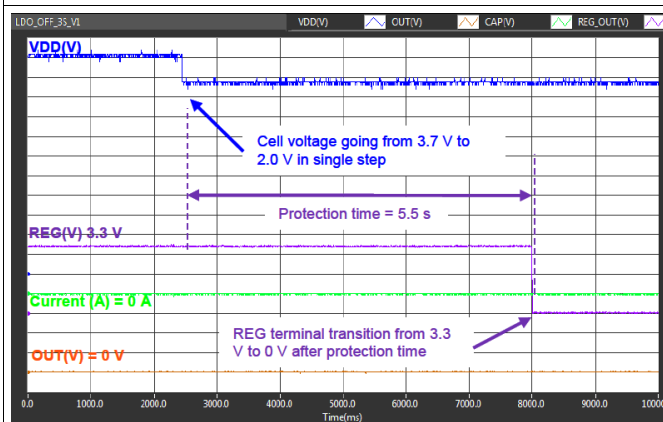

Figure 21. Undervoltage Detection to Turn Off the Regulator

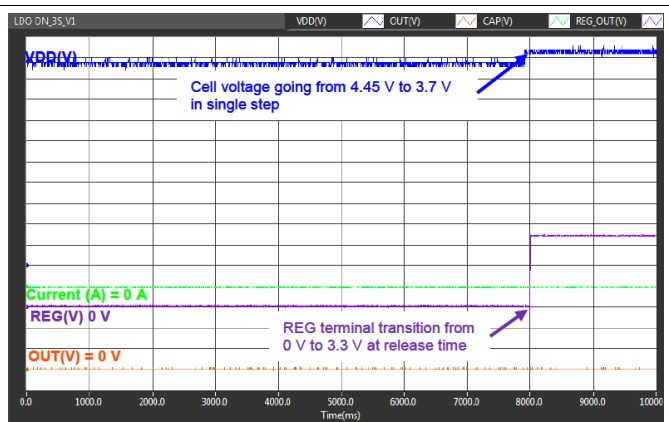
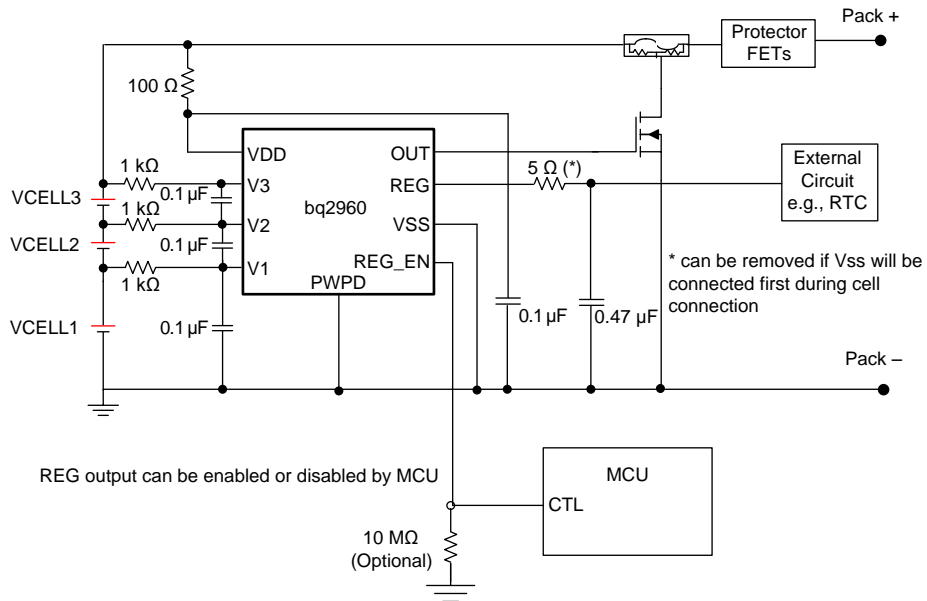
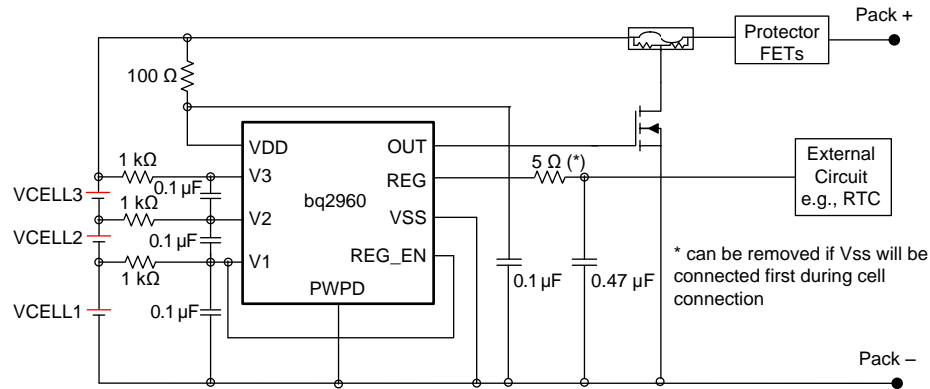

Figure 22. Undervoltage Release to Switch On the Regulator

9.2.4 Other Schematics



Copyright © 2017, Texas Instruments Incorporated

Figure 23. BQ2960 Schematic with REG Output Always Enabled

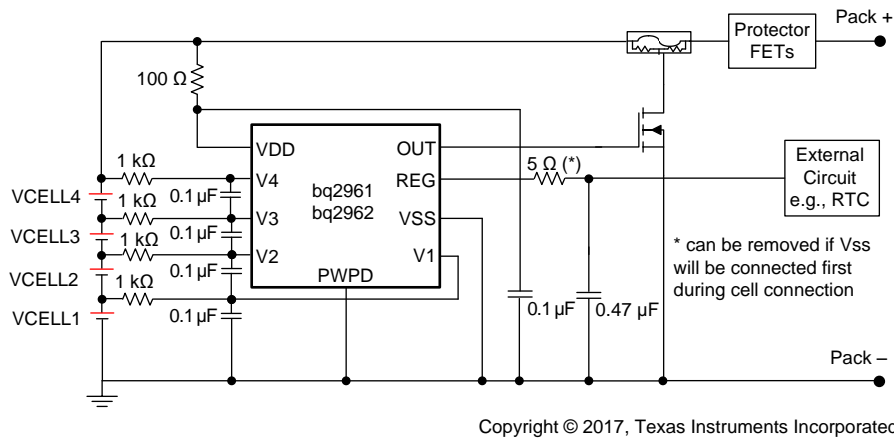

Figure 24. BQ2961 and BQ2962 Schematic

10 Power Supply Recommendations

The maximum power is 15 V for BQ2960 and 20 V for BQ2961 and BQ2962 on VDD.

NOTE

Connect VSS first during power up.

11 Layout

11.1 Layout Guidelines

Use the following layout guidelines:

1. Ensure the RC filters for the Vx pins and VDD pin are placed as close as possible to the target terminal, reducing the tracing loop area.
2. The capacitor for REG should be placed close to the device terminals.
3. Ensure the trace connecting the fuse to the gate, source of the NFET to the Pack- is sufficient to withstand the current during a fuse blown event.

11.2 Layout Example

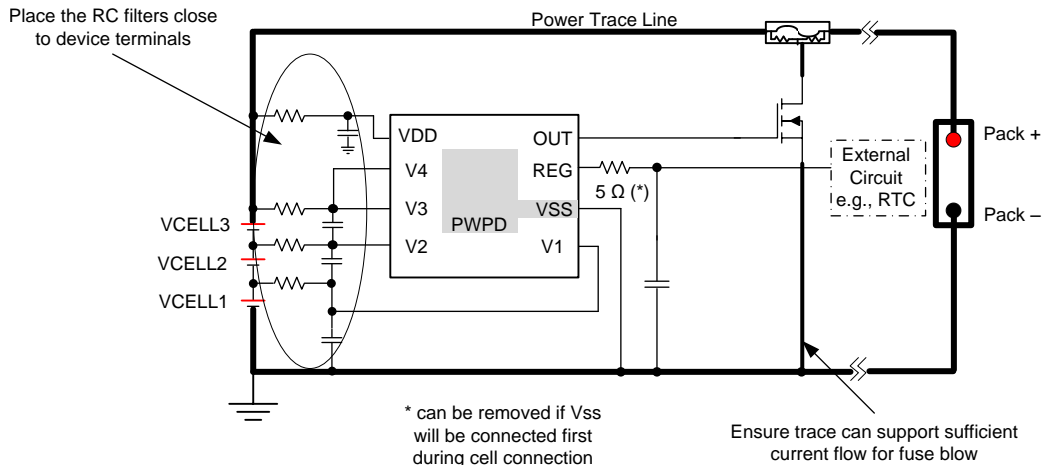

Figure 25. Layout Example

12 Device and Documentation Support

12.1 Receiving Notification of Documentation Updates

To receive notification of documentation updates, navigate to the device product folder on ti.com. In the upper right corner, click on *Alert me* to register and receive a weekly digest of any product information that has changed. For change details, review the revision history included in any revised document.

12.2 Community Resources

The following links connect to TI community resources. Linked contents are provided "AS IS" by the respective contributors. They do not constitute TI specifications and do not necessarily reflect TI's views; see TI's [Terms of Use](#).

TI E2E™ Online Community *TI's Engineer-to-Engineer (E2E) Community*. Created to foster collaboration among engineers. At e2e.ti.com, you can ask questions, share knowledge, explore ideas and help solve problems with fellow engineers.

Design Support *TI's Design Support* Quickly find helpful E2E forums along with design support tools and contact information for technical support.

12.3 Trademarks

E2E is a trademark of Texas Instruments.
All other trademarks are the property of their respective owners.

12.4 Electrostatic Discharge Caution



This integrated circuit can be damaged by ESD. Texas Instruments recommends that all integrated circuits be handled with appropriate precautions. Failure to observe proper handling and installation procedures can cause damage.

ESD damage can range from subtle performance degradation to complete device failure. Precision integrated circuits may be more susceptible to damage because very small parametric changes could cause the device not to meet its published specifications.

12.5 Glossary

[SLYZ022](#) — *TI Glossary*.

This glossary lists and explains terms, acronyms, and definitions.

13 Mechanical, Packaging, and Orderable Information

The following pages include mechanical, packaging, and orderable information. This information is the most current data available for the designated devices. This data is subject to change without notice and revision of this document. For browser-based versions of this data sheet, refer to the left-hand navigation.

PACKAGING INFORMATION

Orderable Device	Status (1)	Package Type	Package Drawing	Pins	Package Qty	Eco Plan (2)	Lead/Ball Finish (6)	MSL Peak Temp (3)	Op Temp (°C)	Device Marking (4/5)	Samples
BQ296100DSGR	ACTIVE	WSO	DSG	8	3000	Green (RoHS & no Sb/Br)	CU NIPDAU	Level-2-260C-1 YEAR	-40 to 110	6100	Samples
BQ296100DSGT	ACTIVE	WSO	DSG	8	250	Green (RoHS & no Sb/Br)	CU NIPDAU	Level-2-260C-1 YEAR	-40 to 110	6100	Samples
BQ296103DSGR	ACTIVE	WSO	DSG	8	3000	Green (RoHS & no Sb/Br)	CU NIPDAU	Level-2-260C-1 YEAR	-40 to 110	6103	Samples
BQ296103DSGT	ACTIVE	WSO	DSG	8	250	Green (RoHS & no Sb/Br)	CU NIPDAU	Level-2-260C-1 YEAR	-40 to 110	6103	Samples
BQ296106DSGR	ACTIVE	WSO	DSG	8	3000	Green (RoHS & no Sb/Br)	CU NIPDAU	Level-2-260C-1 YEAR	-40 to 110	6106	Samples
BQ296106DSGT	ACTIVE	WSO	DSG	8	250	Green (RoHS & no Sb/Br)	CU NIPDAU	Level-2-260C-1 YEAR	-40 to 110	6106	Samples
BQ296107DSGR	ACTIVE	WSO	DSG	8	3000	Green (RoHS & no Sb/Br)	CU NIPDAU	Level-2-260C-1 YEAR	-40 to 110	6107	Samples
BQ296107DSGT	ACTIVE	WSO	DSG	8	250	Green (RoHS & no Sb/Br)	CU NIPDAU	Level-2-260C-1 YEAR	-40 to 110	6107	Samples
BQ296111DSGR	ACTIVE	WSO	DSG	8	3000	Green (RoHS & no Sb/Br)	CU NIPDAU	Level-2-260C-1 YEAR	-40 to 110	6111	Samples
BQ296111DSGT	ACTIVE	WSO	DSG	8	250	Green (RoHS & no Sb/Br)	CU NIPDAU	Level-2-260C-1 YEAR	-40 to 110	6111	Samples
BQ296112DSGR	ACTIVE	WSO	DSG	8	3000	Green (RoHS & no Sb/Br)	CU NIPDAU	Level-2-260C-1 YEAR	-40 to 110	6112	Samples
BQ296112DSGT	ACTIVE	WSO	DSG	8	250	Green (RoHS & no Sb/Br)	CU NIPDAU	Level-2-260C-1 YEAR	-40 to 110	6112	Samples
BQ296113DSGR	ACTIVE	WSO	DSG	8	3000	Green (RoHS & no Sb/Br)	CU NIPDAU	Level-2-260C-1 YEAR	-40 to 110	6113	Samples
BQ296113DSGT	ACTIVE	WSO	DSG	8	250	Green (RoHS & no Sb/Br)	CU NIPDAU	Level-2-260C-1 YEAR	-40 to 110	6113	Samples
BQ296114DSGR	ACTIVE	WSO	DSG	8	3000	Green (RoHS & no Sb/Br)	CU NIPDAU	Level-2-260C-1 YEAR	-40 to 110	6114	Samples
BQ296114DSGT	ACTIVE	WSO	DSG	8	250	Green (RoHS & no Sb/Br)	CU NIPDAU	Level-2-260C-1 YEAR	-40 to 110	6114	Samples
BQ296202DSGR	ACTIVE	WSO	DSG	8	3000	Green (RoHS & no Sb/Br)	CU NIPDAU	Level-2-260C-1 YEAR	-40 to 110	6202	Samples

Orderable Device	Status (1)	Package Type	Package Drawing	Pins	Package Qty	Eco Plan (2)	Lead/Ball Finish (6)	MSL Peak Temp (3)	Op Temp (°C)	Device Marking (4/5)	Samples
BQ296202DSGT	ACTIVE	WSON	DSG	8	250	Green (RoHS & no Sb/Br)	CU NIPDAU	Level-2-260C-1 YEAR	-40 to 110	6202	Samples
BQ296203DSGR	ACTIVE	WSON	DSG	8	3000	Green (RoHS & no Sb/Br)	CU NIPDAU	Level-2-260C-1 YEAR	-40 to 110	6203	Samples
BQ296203DSGT	ACTIVE	WSON	DSG	8	250	Green (RoHS & no Sb/Br)	CU NIPDAU	Level-2-260C-1 YEAR	-40 to 110	6203	Samples
BQ296212DSGR	ACTIVE	WSON	DSG	8	3000	Green (RoHS & no Sb/Br)	CU NIPDAU	Level-2-260C-1 YEAR	-40 to 110	6212	Samples
BQ296212DSGT	ACTIVE	WSON	DSG	8	250	Green (RoHS & no Sb/Br)	CU NIPDAU	Level-2-260C-1 YEAR	-40 to 110	6212	Samples
BQ296213DSGR	ACTIVE	WSON	DSG	8	3000	Green (RoHS & no Sb/Br)	CU NIPDAU	Level-2-260C-1 YEAR	-40 to 110	6213	Samples
BQ296213DSGT	ACTIVE	WSON	DSG	8	250	Green (RoHS & no Sb/Br)	CU NIPDAU	Level-2-260C-1 YEAR	-40 to 110	6213	Samples
BQ296216DSGR	ACTIVE	WSON	DSG	8	3000	Green (RoHS & no Sb/Br)	CU NIPDAU	Level-2-260C-1 YEAR	-40 to 110	6216	Samples
BQ296216DSGT	ACTIVE	WSON	DSG	8	250	Green (RoHS & no Sb/Br)	CU NIPDAU	Level-2-260C-1 YEAR	-40 to 110	6216	Samples
BQ296217DSGR	ACTIVE	WSON	DSG	8	3000	Green (RoHS & no Sb/Br)	CU NIPDAU	Level-2-260C-1 YEAR	-40 to 110	6217	Samples
BQ296217DSGT	ACTIVE	WSON	DSG	8	250	Green (RoHS & no Sb/Br)	CU NIPDAU	Level-2-260C-1 YEAR	-40 to 110	6217	Samples
BQ296223DSGR	PREVIEW	WSON	DSG	8	3000	Green (RoHS & no Sb/Br)	CU NIPDAU	Level-2-260C-1 YEAR	-40 to 110	6223	
BQ296223DSGT	PREVIEW	WSON	DSG	8	250	Green (RoHS & no Sb/Br)	CU NIPDAU	Level-2-260C-1 YEAR	-40 to 110	6223	
BQ296224DSGR	PREVIEW	WSON	DSG	8	3000	Green (RoHS & no Sb/Br)	CU NIPDAU	Level-2-260C-1 YEAR	-40 to 110	6224	
BQ296224DSGT	PREVIEW	WSON	DSG	8	250	Green (RoHS & no Sb/Br)	CU NIPDAU	Level-2-260C-1 YEAR	-40 to 110	6224	

(1) The marketing status values are defined as follows:

ACTIVE: Product device recommended for new designs.

LIFEBUY: TI has announced that the device will be discontinued, and a lifetime-buy period is in effect.

NRND: Not recommended for new designs. Device is in production to support existing customers, but TI does not recommend using this part in a new design.

PREVIEW: Device has been announced but is not in production. Samples may or may not be available.

OBSOLETE: TI has discontinued the production of the device.

⁽²⁾ **RoHS:** TI defines "RoHS" to mean semiconductor products that are compliant with the current EU RoHS requirements for all 10 RoHS substances, including the requirement that RoHS substance do not exceed 0.1% by weight in homogeneous materials. Where designed to be soldered at high temperatures, "RoHS" products are suitable for use in specified lead-free processes. TI may reference these types of products as "Pb-Free".

RoHS Exempt: TI defines "RoHS Exempt" to mean products that contain lead but are compliant with EU RoHS pursuant to a specific EU RoHS exemption.

Green: TI defines "Green" to mean the content of Chlorine (Cl) and Bromine (Br) based flame retardants meet JS709B low halogen requirements of ≤ 1000 ppm threshold. Antimony trioxide based flame retardants must also meet the ≤ 1000 ppm threshold requirement.

⁽³⁾ **MSL, Peak Temp.** - The Moisture Sensitivity Level rating according to the JEDEC industry standard classifications, and peak solder temperature.

⁽⁴⁾ There may be additional marking, which relates to the logo, the lot trace code information, or the environmental category on the device.

⁽⁵⁾ Multiple Device Markings will be inside parentheses. Only one Device Marking contained in parentheses and separated by a "-" will appear on a device. If a line is indented then it is a continuation of the previous line and the two combined represent the entire Device Marking for that device.

⁽⁶⁾ **Lead/Ball Finish** - Orderable Devices may have multiple material finish options. Finish options are separated by a vertical ruled line. Lead/Ball Finish values may wrap to two lines if the finish value exceeds the maximum column width.

Important Information and Disclaimer: The information provided on this page represents TI's knowledge and belief as of the date that it is provided. TI bases its knowledge and belief on information provided by third parties, and makes no representation or warranty as to the accuracy of such information. Efforts are underway to better integrate information from third parties. TI has taken and continues to take reasonable steps to provide representative and accurate information but may not have conducted destructive testing or chemical analysis on incoming materials and chemicals. TI and TI suppliers consider certain information to be proprietary, and thus CAS numbers and other limited information may not be available for release.

In no event shall TI's liability arising out of such information exceed the total purchase price of the TI part(s) at issue in this document sold by TI to Customer on an annual basis.

TAPE AND REEL INFORMATION

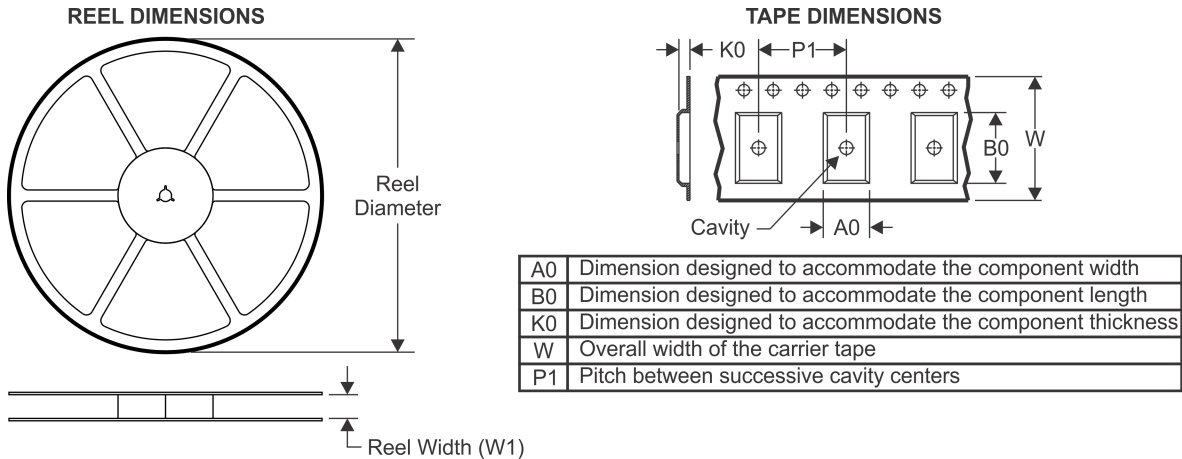

QUADRANT ASSIGNMENTS FOR PIN 1 ORIENTATION IN TAPE



*All dimensions are nominal

Device	Package Type	Package Drawing	Pins	SPQ	Reel Diameter (mm)	Reel Width W1 (mm)	A0 (mm)	B0 (mm)	K0 (mm)	P1 (mm)	W (mm)	Pin1 Quadrant
BQ296100DSGR	WSON	DSG	8	3000	180.0	8.4	2.3	2.3	1.15	4.0	8.0	Q2
BQ296100DSGT	WSON	DSG	8	250	180.0	8.4	2.3	2.3	1.15	4.0	8.0	Q2
BQ296103DSGR	WSON	DSG	8	3000	180.0	8.4	2.3	2.3	1.15	4.0	8.0	Q2
BQ296103DSGT	WSON	DSG	8	250	180.0	8.4	2.3	2.3	1.15	4.0	8.0	Q2
BQ296106DSGR	WSON	DSG	8	3000	180.0	8.4	2.3	2.3	1.15	4.0	8.0	Q2
BQ296106DSGT	WSON	DSG	8	250	180.0	8.4	2.3	2.3	1.15	4.0	8.0	Q2
BQ296111DSGR	WSON	DSG	8	3000	180.0	8.4	2.3	2.3	1.15	4.0	8.0	Q2
BQ296111DSGT	WSON	DSG	8	250	180.0	8.4	2.3	2.3	1.15	4.0	8.0	Q2
BQ296112DSGR	WSON	DSG	8	3000	180.0	8.4	2.3	2.3	1.15	4.0	8.0	Q2
BQ296112DSGT	WSON	DSG	8	250	180.0	8.4	2.3	2.3	1.15	4.0	8.0	Q2
BQ296113DSGR	WSON	DSG	8	3000	180.0	8.4	2.3	2.3	1.15	4.0	8.0	Q2
BQ296113DSGT	WSON	DSG	8	250	180.0	8.4	2.3	2.3	1.15	4.0	8.0	Q2
BQ296114DSGR	WSON	DSG	8	3000	180.0	8.4	2.3	2.3	1.15	4.0	8.0	Q2
BQ296114DSGT	WSON	DSG	8	250	180.0	8.4	2.3	2.3	1.15	4.0	8.0	Q2
BQ296202DSGR	WSON	DSG	8	3000	180.0	8.4	2.3	2.3	1.15	4.0	8.0	Q2
BQ296202DSGT	WSON	DSG	8	250	180.0	8.4	2.3	2.3	1.15	4.0	8.0	Q2
BQ296203DSGR	WSON	DSG	8	3000	180.0	8.4	2.3	2.3	1.15	4.0	8.0	Q2
BQ296203DSGT	WSON	DSG	8	250	180.0	8.4	2.3	2.3	1.15	4.0	8.0	Q2

Device	Package Type	Package Drawing	Pins	SPQ	Reel Diameter (mm)	Reel Width W1 (mm)	A0 (mm)	B0 (mm)	K0 (mm)	P1 (mm)	W (mm)	Pin1 Quadrant
BQ296212DSGR	WSON	DSG	8	3000	180.0	8.4	2.3	2.3	1.15	4.0	8.0	Q2
BQ296212DSGT	WSON	DSG	8	250	180.0	8.4	2.3	2.3	1.15	4.0	8.0	Q2
BQ296213DSGR	WSON	DSG	8	3000	180.0	8.4	2.3	2.3	1.15	4.0	8.0	Q2
BQ296213DSGT	WSON	DSG	8	250	180.0	8.4	2.3	2.3	1.15	4.0	8.0	Q2
BQ296216DSGR	WSON	DSG	8	3000	180.0	8.4	2.3	2.3	1.15	4.0	8.0	Q2
BQ296216DSGT	WSON	DSG	8	250	180.0	8.4	2.3	2.3	1.15	4.0	8.0	Q2
BQ296217DSGR	WSON	DSG	8	3000	180.0	8.4	2.3	2.3	1.15	4.0	8.0	Q2
BQ296217DSGT	WSON	DSG	8	250	180.0	8.4	2.3	2.3	1.15	4.0	8.0	Q2

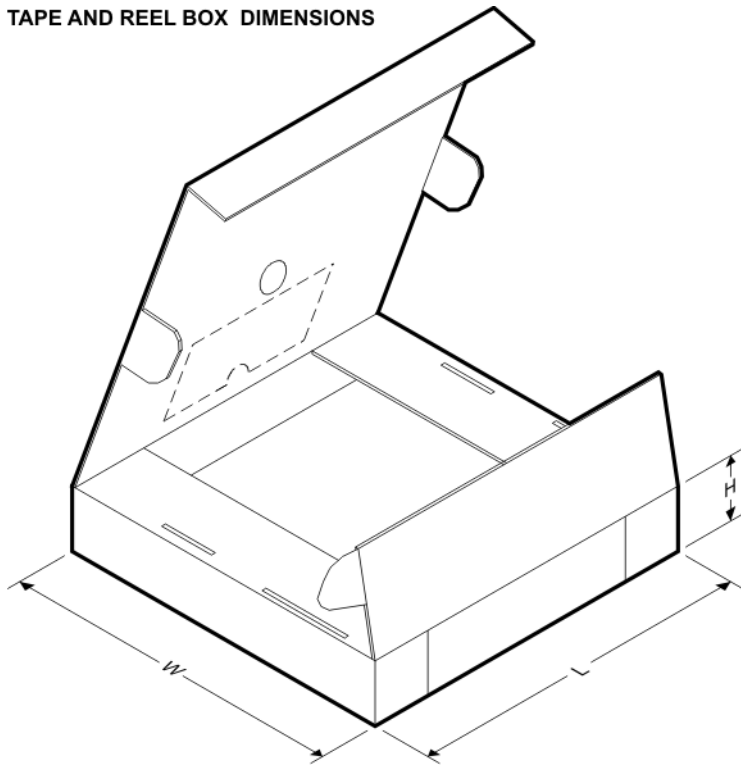
TAPE AND REEL BOX DIMENSIONS

*All dimensions are nominal

Device	Package Type	Package Drawing	Pins	SPQ	Length (mm)	Width (mm)	Height (mm)
BQ296100DSGR	WSON	DSG	8	3000	210.0	185.0	35.0
BQ296100DSGT	WSON	DSG	8	250	210.0	185.0	35.0
BQ296103DSGR	WSON	DSG	8	3000	210.0	185.0	35.0
BQ296103DSGT	WSON	DSG	8	250	210.0	185.0	35.0
BQ296106DSGR	WSON	DSG	8	3000	210.0	185.0	35.0
BQ296106DSGT	WSON	DSG	8	250	210.0	185.0	35.0
BQ296111DSGR	WSON	DSG	8	3000	210.0	185.0	35.0
BQ296111DSGT	WSON	DSG	8	250	210.0	185.0	35.0
BQ296112DSGR	WSON	DSG	8	3000	210.0	185.0	35.0

Device	Package Type	Package Drawing	Pins	SPQ	Length (mm)	Width (mm)	Height (mm)
BQ296112DSGT	WSON	DSG	8	250	210.0	185.0	35.0
BQ296113DSGR	WSON	DSG	8	3000	210.0	185.0	35.0
BQ296113DSGT	WSON	DSG	8	250	210.0	185.0	35.0
BQ296114DSGR	WSON	DSG	8	3000	210.0	185.0	35.0
BQ296114DSGT	WSON	DSG	8	250	210.0	185.0	35.0
BQ296202DSGR	WSON	DSG	8	3000	210.0	185.0	35.0
BQ296202DSGT	WSON	DSG	8	250	210.0	185.0	35.0
BQ296203DSGR	WSON	DSG	8	3000	210.0	185.0	35.0
BQ296203DSGT	WSON	DSG	8	250	210.0	185.0	35.0
BQ296212DSGR	WSON	DSG	8	3000	210.0	185.0	35.0
BQ296212DSGT	WSON	DSG	8	250	210.0	185.0	35.0
BQ296213DSGR	WSON	DSG	8	3000	210.0	185.0	35.0
BQ296213DSGT	WSON	DSG	8	250	210.0	185.0	35.0
BQ296216DSGR	WSON	DSG	8	3000	210.0	185.0	35.0
BQ296216DSGT	WSON	DSG	8	250	210.0	185.0	35.0
BQ296217DSGR	WSON	DSG	8	3000	210.0	185.0	35.0
BQ296217DSGT	WSON	DSG	8	250	210.0	185.0	35.0

GENERIC PACKAGE VIEW

DSG 8

WSON - 0.8 mm max height

2 x 2, 0.5 mm pitch

PLASTIC SMALL OUTLINE - NO LEAD

This image is a representation of the package family, actual package may vary.
Refer to the product data sheet for package details.

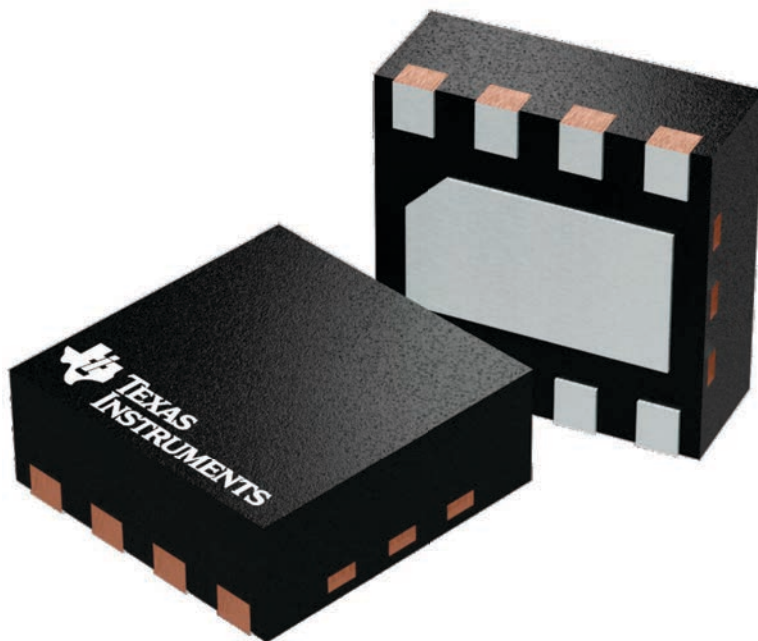

4224783/A

DSG0008A

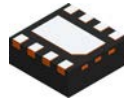

PACKAGE OUTLINE

WSON - 0.8 mm max height

PLASTIC SMALL OUTLINE - NO LEAD

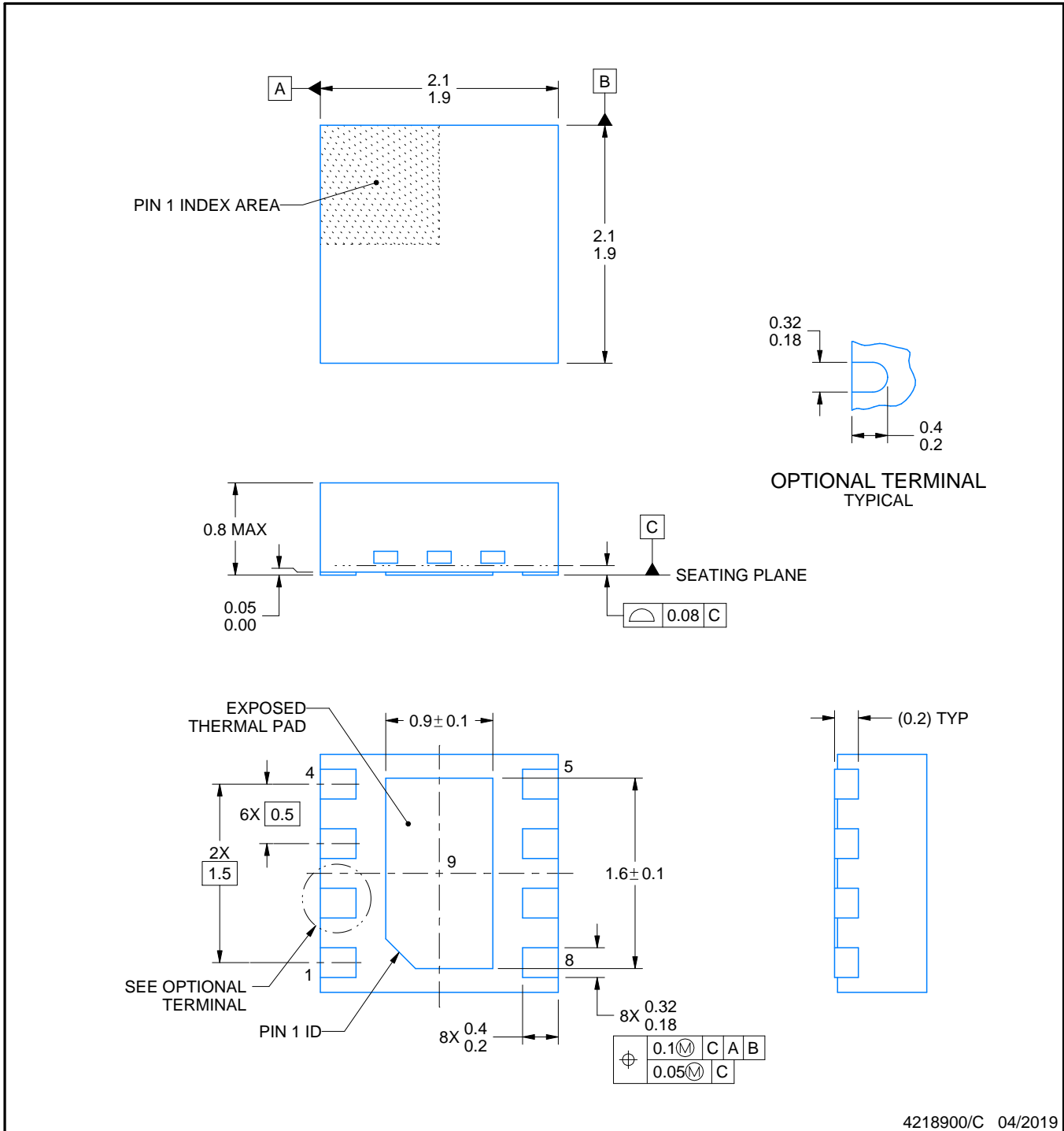

4218900/C 04/2019

NOTES:

1. All linear dimensions are in millimeters. Any dimensions in parenthesis are for reference only. Dimensioning and tolerancing per ASME Y14.5M.
2. This drawing is subject to change without notice.
3. The package thermal pad must be soldered to the printed circuit board for thermal and mechanical performance.

EXAMPLE BOARD LAYOUT

DSG0008A

WSON - 0.8 mm max height

PLASTIC SMALL OUTLINE - NO LEAD

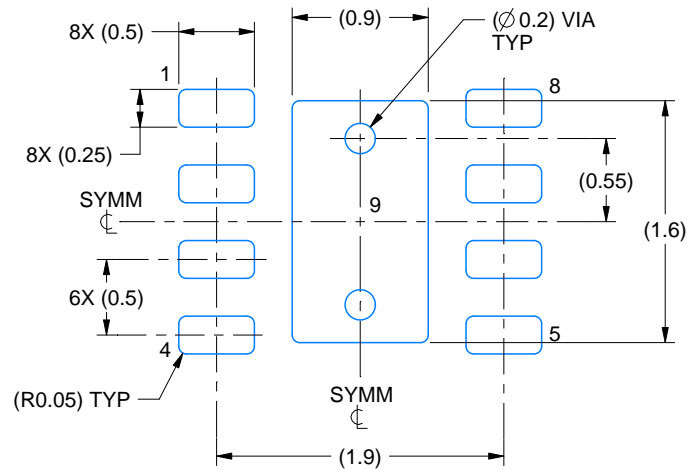

LAND PATTERN EXAMPLE
SCALE:20X

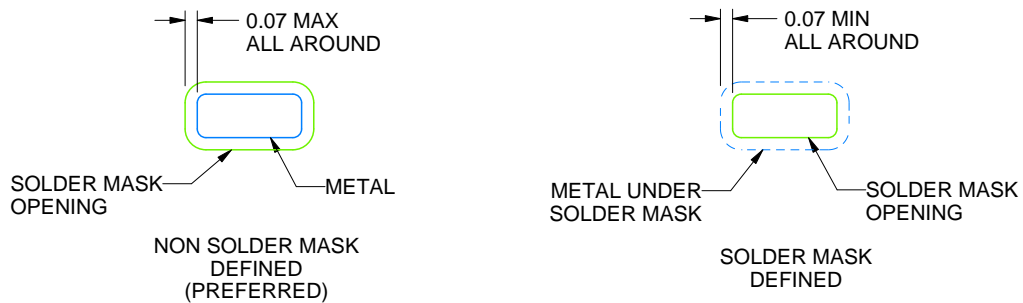

SOLDER MASK DETAILS

4218900/C 04/2019

NOTES: (continued)

4. This package is designed to be soldered to a thermal pad on the board. For more information, see Texas Instruments literature number SLUA271 (www.ti.com/lit/slua271).
5. Vias are optional depending on application, refer to device data sheet. If any vias are implemented, refer to their locations shown on this view. It is recommended that vias under paste be filled, plugged or tented.

EXAMPLE STENCIL DESIGN

DSG0008A

WSON - 0.8 mm max height

PLASTIC SMALL OUTLINE - NO LEAD

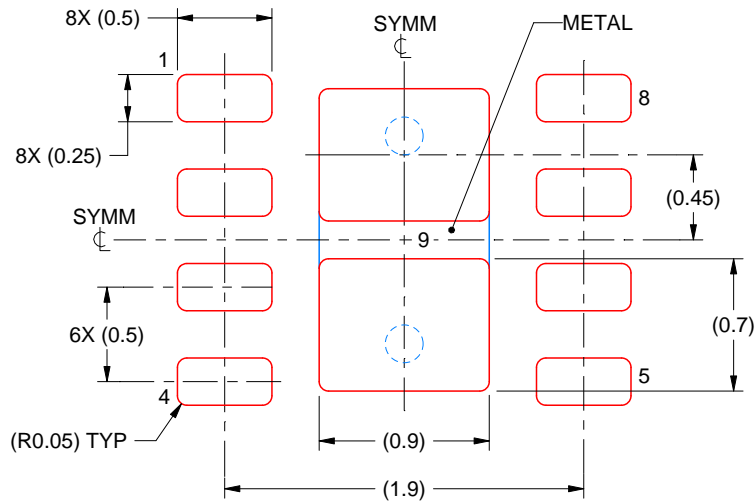

SOLDER PASTE EXAMPLE
BASED ON 0.125 mm THICK STENCIL

EXPOSED PAD 9:
87% PRINTED SOLDER COVERAGE BY AREA UNDER PACKAGE
SCALE:25X

4218900/C 04/2019

NOTES: (continued)

6. Laser cutting apertures with trapezoidal walls and rounded corners may offer better paste release. IPC-7525 may have alternate design recommendations.

IMPORTANT NOTICE AND DISCLAIMER

TI PROVIDES TECHNICAL AND RELIABILITY DATA (INCLUDING DATASHEETS), DESIGN RESOURCES (INCLUDING REFERENCE DESIGNS), APPLICATION OR OTHER DESIGN ADVICE, WEB TOOLS, SAFETY INFORMATION, AND OTHER RESOURCES "AS IS" AND WITH ALL FAULTS, AND DISCLAIMS ALL WARRANTIES, EXPRESS AND IMPLIED, INCLUDING WITHOUT LIMITATION ANY IMPLIED WARRANTIES OF MERCHANTABILITY, FITNESS FOR A PARTICULAR PURPOSE OR NON-INFRINGEMENT OF THIRD PARTY INTELLECTUAL PROPERTY RIGHTS.

These resources are intended for skilled developers designing with TI products. You are solely responsible for (1) selecting the appropriate TI products for your application, (2) designing, validating and testing your application, and (3) ensuring your application meets applicable standards, and any other safety, security, or other requirements. These resources are subject to change without notice. TI grants you permission to use these resources only for development of an application that uses the TI products described in the resource. Other reproduction and display of these resources is prohibited. No license is granted to any other TI intellectual property right or to any third party intellectual property right. TI disclaims responsibility for, and you will fully indemnify TI and its representatives against, any claims, damages, costs, losses, and liabilities arising out of your use of these resources.

TI's products are provided subject to TI's Terms of Sale (www.ti.com/legal/termsofsale.html) or other applicable terms available either on ti.com or provided in conjunction with such TI products. TI's provision of these resources does not expand or otherwise alter TI's applicable warranties or warranty disclaimers for TI products.

Mailing Address: Texas Instruments, Post Office Box 655303, Dallas, Texas 75265
Copyright © 2019, Texas Instruments Incorporated