

PART NAME: KNOB SCALE: 1:1 DATE: 2/1/07 DR. BY JAM

DAVIES MOLDING COMPANY
CAROL STREAM, ILLINOIS 60188

P/N	1506
MOLD #	1505/1506/2813
CAVITY	1506
CORE	1506
PIN	1506

THIS DRAWING IS THE PROPERTY OF DAVIES MOLDING COMPANY, IS SUBMITTED SOLELY AS A DESIGN OR ENGINEERING PROJECT. WE ACCEPT NO RESPONSIBILITY WHATSOEVER FOR THE PRACTICAL APPLICATION OF THE PIECES MADE TO THIS DESIGN.

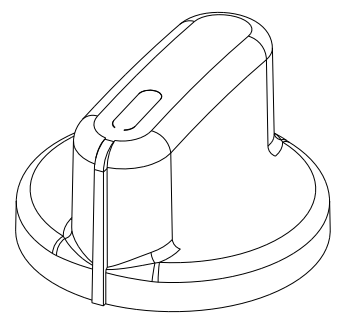
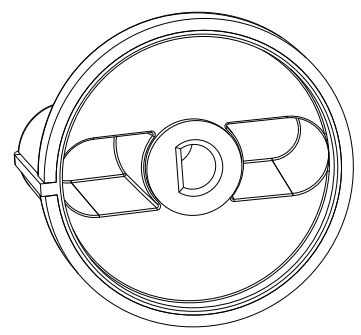
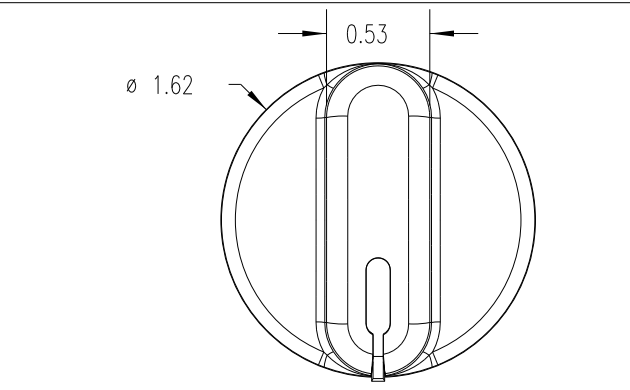

(B)

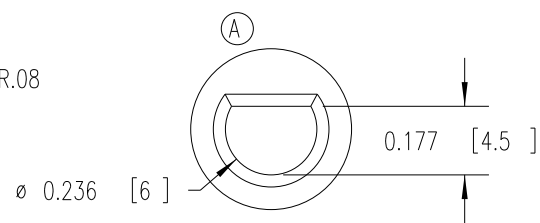
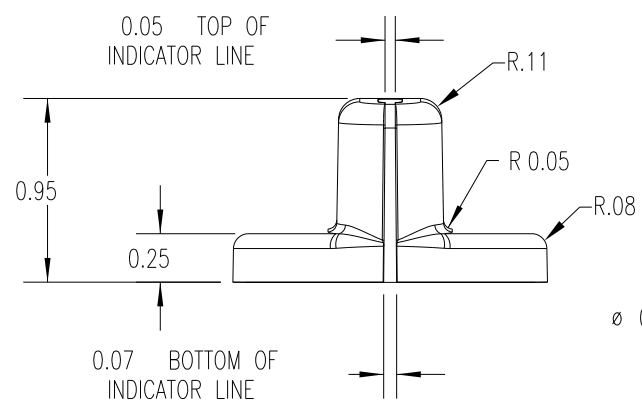

DETAIL D
SCALE 2 : 1

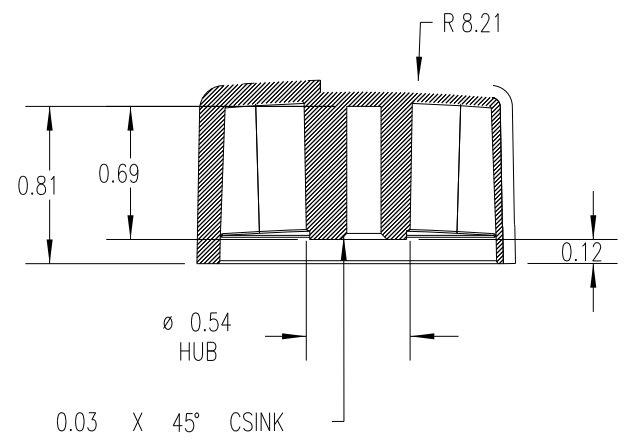

SECTION A-A

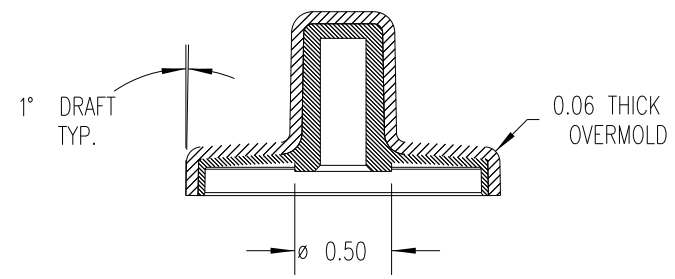
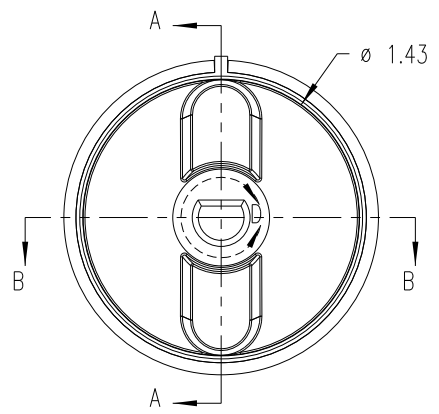

SECTION B-B

MATERIAL: SUBSTRATE: POLYPROPYLENE (CLD)
OVERMOLD : TPE (TPE3)

COLOR: SUBSTRATE: WHITE (PC23083)
OVERMOLD: BLACK

TOLERANCES: UNLESS OTHERWISE SPECIFIED	DO NOT SCALE DRAWING	B	MOLD # WAS 1506	JAM	12/14/09
DECIMALS: X.XXX ± .005 X.XX ± .015	MM: X.XX ± 0.15MM X.X ± 0.4MM	A	TURNED "D" HOLE 180	JAM	5/14/07
FRACTIONS ± 1/64	ANG. ± 1°	-	WAS SK1506-07	JAM	2/1/07
CHANGES					