

Protection Thyristor SP1200SA ~ SP2500SC

■ Features

- Low voltage overshoot
- Low on-state voltage
- Does not degrade with use
- HF ROHS Asymmetrical Discrete Series- DO-214

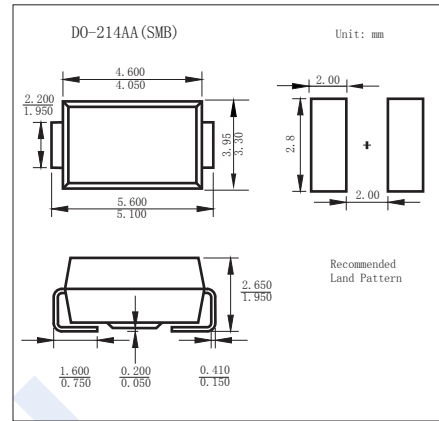

■ Absolute Maximum Ratings $T_a = 25^\circ\text{C}$

Parameter	Symbol	Rating	Unit
Thermal Resistance Junction to Ambient	R_{thJA}	90	$^\circ\text{C}/\text{W}$
Junction Temperature	T_J	-40 to 150	$^\circ\text{C}$
Storage Temperature Range	T_{stg}	-65 to 150	

■ Electrical Characteristics ($T_a = 25^\circ\text{C}$, unless otherwise noted.)

Part Number	Marking	V_{DRM} @ $I_{DRM} = 5\mu\text{A}$	V_S @100V/ μs	I_H	I_S	I_T	V_T @ $I_T = 2.2\text{A}$	Capacitance @1MHz, 2V bias	
		V min	V max	mA min	mA max	A max	V max	pF min	pF min
SP1200SA	P12A	100	130	120	800	2.2	4	30	45
SP2000SA	P20A	180	220	120	800	2.2	4	25	35
SP2500SA	P25A	230	290	120	800	2.2	4	20	35
SP1200SB	P12B	100	130	120	800	2.2	4	30	65
SP2000SB	P20B	180	220	120	800	2.2	4	25	95
SP2500SB	P25B	230	290	120	800	2.2	4	35	95
SP1200SC	P12C	100	130	120	800	2.2	4	20	35
SP2000SC	P20C	180	220	120	800	2.2	4	20	35
SP2500SC	P25C	230	290	120	800	2.2	4	30	85

■ Surge Ratings

Series	I_{PP}										I_{TSM} 50/60 Hz	di/dt	
	0.2x310 ¹ 0.5x700 ²	2x10 ¹ 2x10 ²	8x20 ¹ 1.2x50 ²	10x160 ¹ 10x160 ²	10x560 ¹ 10x560 ²	5x320 ¹ 9x720 ²	10x360 ¹ 10x360 ²	10x1000 ¹ 10x1000 ²	5x310 ¹ 10x700 ²	A min			A min
	A min	A min	A min	A min	A min	A min	A min	A min	A min	A min			Amps/ μs max
A	20	150	150	90	50	75	75	45	75	20	500		
B	25	250	250	150	100	100	125	80	100	25	500		
C	50	500	400	200	150	200	175	100	200	30	500		

Notes:

1 Current waveform in μs
2 Voltage waveform in μs

- Peak pulse current rating (I_{PP}) is repetitive and guaranteed for the life of the product.
- I_{PP} ratings applicable over temperature range of -40°C to $+85^\circ\text{C}$
- The device must initially be in thermal equilibrium with $-40^\circ\text{C} \leq T_J \leq +150^\circ\text{C}$

Protection Thyristor SP1200SA ~ SP2500SC

■ Typical Characteristics

V-I Characteristics

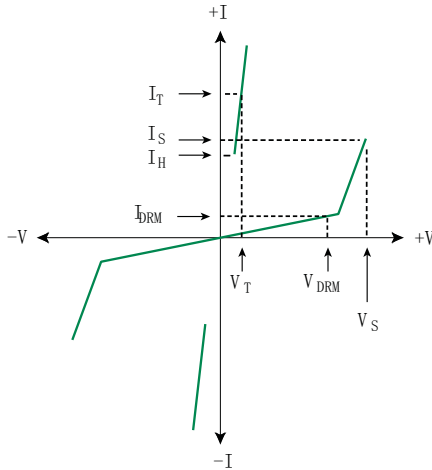

$t_r \times t_d$ Pulse Waveform

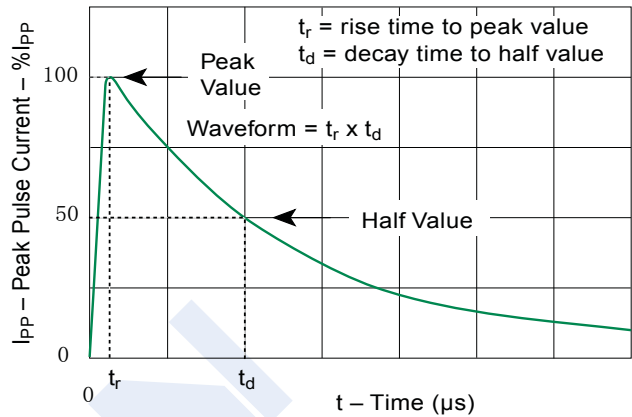

Normalized V_S Change vs. Junction Temperature

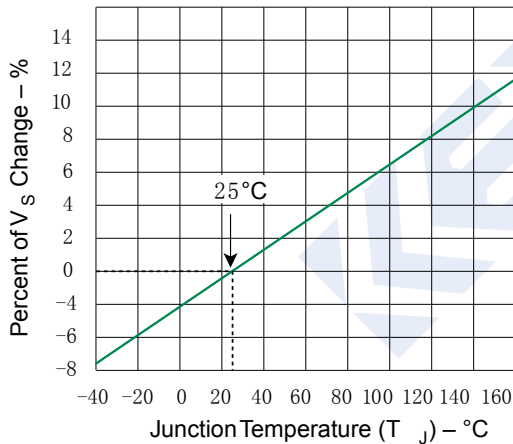

Normalized DC Holding Current vs. Case Temperature

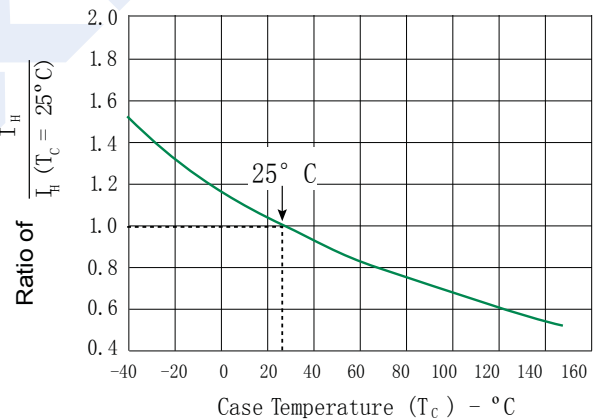

Reflow Condition		Pb-Free assembly (see Fig. 1)
Pre Heat	-Temperature Min ($T_{s(min)}$)	+150°C
	-Temperature Max ($T_{s(max)}$)	+200°C
	-Time (Min to Max) (t_s)	60-180 secs.
Average ramp up rate (Liquidus Temp (T_L) to peak)		3°C/sec. Max.
$T_{s(max)}$ to T_L - Ramp-up Rate		3°C/sec. Max.
Reflow	-Temperature (T_L) (Liquidus)	+217°C
	-Temperature (t_L)	60-150 secs.
Peak Temp (T_p)		+260(+0/-5)°C
Time within 5°C of actual Peak Temp (t_p)		30 secs. Max.
Ramp-down Rate		6°C/sec. Max.
Time 25°C to Peak Temp (T_p)		8 min. Max.
Do not exceed		+260°C

