

TOP VIEW

To be used with swivel lid sockets.
 Compression screw needs to be turned clockwise up to the point where the arrow on top of the compression screw aligns with laser mark on the compression screw bottom.

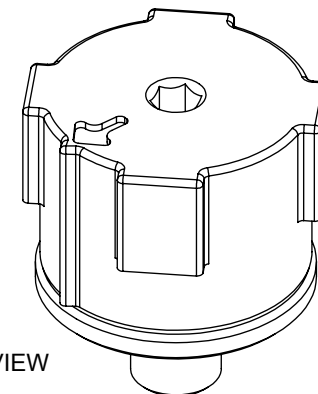

ISO VIEW

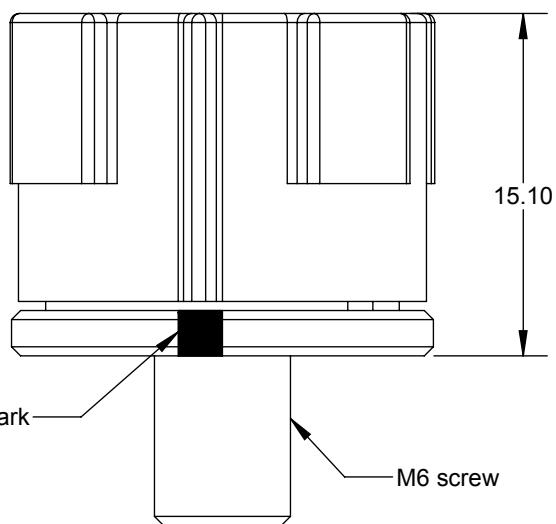

FRONT VIEW

Ordering Information

Part Number	Torque (in. lb)
TS-SG-03-03	0.3
TS-SG-03-0.4	0.4
TS-SG-03-0.5	0.5
TS-SG-03-0.75	0.75
TS-SG-03-1.0	1.0
TS-SG-03-1.25	1.25
TS-SG-03-1.5	1.5
TS-SG-03-1.75	1.75
TS-SG-03-2.0	2.0

Note: Torque indicating screw requires calibration at Ironwood to a specific torque value.

Order by part # to obtain the appropriate screw with the correct torque value for your application

Doc Rev	Date	Initials	Description
A	5/27/08	VP	Original
B	8/10/09	VP	Added table to include additional part numbers
C	9/21/12	ELS	VW to SW conversion
D	1/21/14	ELS	Added TS-SG-03-0.3 and TS-SG-03-0.4 to the table

Description: Torque indicating compression screw, M6 thread

Primary dimension units are millimeters, Secondary dimension units are [inches], Weight is in grams.
 Tolerances: Hole diameters $\pm 0.0254\text{mm}$ [$\pm 0.001"$], Pitches (from true position) $\pm 0.0254\text{mm}$ [$\pm 0.001"$], substrate thickness tolerance $\pm 10\%$, all other tolerances $\pm 0.127\text{mm}$ [$\pm 0.005"$] unless stated otherwise. Materials and specifications are subject to change without notice.

TS-SG-03-x.x Specification		STATUS: Released	SHEET: 1 OF 1	REV. D
 Ironwood Electronics, Inc. Tele: (800) 404-0204 www.ironwoodelectronics.com	Material: N/A	ENG: E. Smolentseva	DRAWN BY: E. Smolentseva	SCALE: 3:1
	Finish: N/A	FILE: TS-SG-03-x.x	DATE: 9/21/12	
	Weight: 8.36			