



-Preliminary-

AP1150ADSXX

14V Input / 200mA Output LDO Regulator

1. General Description

The AP1150ADSxx is a low dropout linear regulator with ON/OFF control, which can supply 200mA load current. The IC is an integrated circuit with a silicon monolithic bipolar structure. The output voltage, trimmed with high accuracy, is available from 1.3 to 9.5V in 0.1V steps.

The output capacitor is available to use a small 0.1uF ceramic capacitor ($1.8V \leq V_{out}$). The over current, thermal and reverse bias protections are integrated, and also the package is small and thin type. The IC is designed for space saving requirements.

2. Feature

- Available to use a small 0.1uF ceramic capacitor ($1.8V \leq V_{OUT}$)
- Dropout Voltage $V_{DROP}=120mV$ at 100mA
- High Precision output voltage $\pm 1.5\%$ or $\pm 50mV$
- High ripple rejection ratio 80dB at 1kHz
- Wide operating voltage range 2.1V to 14V
- Very low quiescent current $I_Q=63\mu A$ at $I_{OUT}=0mA$
- On/Off control (High active)
- Built-in Short circuit protection, thermal shutdown
- Built-in reverse bias over current protection
- Available very low noise application
- Very small surface mount package SOT23-5

3. Application

- Any Electronic Equipment
- Battery Powered Systems
- Mobile Communication

4. Table of Contents

1. General Description	1
2. Feature.....	1
3. Application.....	1
4. Table of Contents.....	2
5. Block Diagram	3
6. Ordering Information	4
7. Pin Configurations and Functions.....	5
■ Pin Configurations.....	5
■ Functions	5
8. Absolute Maximum Ratings	6
9. Recommended Operating Conditions	6
10. Electrical Characteristics.....	7
■ Electrical Characteristics of Ta=Tj=25°C	7
■ Electrical Characteristics of Ta=-40°C~85°C.....	9
11. Description	11
11.1 DC Characteristics.....	11
11.2 Input / output capacitors	11
11.3 Bias voltage and temperature characteristics of the ceramic capacitor	13
11.4 On/off control.....	13
11.5 Noise Bypass	13
11.6 Board Layout	14
12. Definition of term.....	16
13. Recommended External Circuits.....	17
■ External Circuit	17
■ Test Circuit	17
14. Package	18
■ Outline Dimensions	18
IMPORTANT NOTICE.....	19

5. Block Diagram



Figure 1. Block Diagram

6. Ordering Information

AP1150ADSXX Ta = -40 to 85°C SOT23-5

- Output Voltage Code

For product name, please check the below chart. Please contact your authorized ASAHI KASEI MICRODEVICES representative for voltage availability.

AP1150ADSXX

└─── Output voltage code

Table 1. Standard Voltage Version, Output Voltage & Voltage Code

XX	VOUT	XX	VOUT	XX	VOUT
15	1.5	33	3.3	50	5.0
18	1.8	40	4.0	54	5.4
30	3.0	45	4.5		

Table 2. Optional Voltage Version, Output Voltage & Voltage Code

XX	VOUT	XX	VOUT	XX	VOUT	XX	VOUT
13	1.3	27	2.7	42	4.2	65	6.5
14	1.4	28	2.8	43	4.3	70	7.0
16	1.6	29	2.9	44	4.4	75	7.5
17	1.7	31	3.1	46	4.6	80	8.0
19	1.9	32	3.2	47	4.7	85	8.5
20	2.0	34	3.4	48	4.8	90	9.0
21	2.1	35	3.5	49	4.9	95	9.5
22	2.2	36	3.6	51	5.1		
23	2.3	37	3.7	52	5.2		
24	2.4	38	3.8	53	5.3		
25	2.5	39	3.9	55	5.5		
26	2.6	41	4.1	60	6.0		

7. Pin Configurations and Functions

■ Pin Configurations

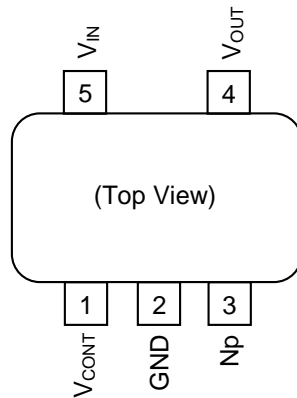

■ Functions

Pin No.	Pin Description	Internal Equivalent Circuit	Description
1	V _{CONT}		<p>On/Off Control Terminal</p> <p>The pull-down resistor (500kΩ) is built-in.</p>
2	GND		GND Terminal
3	Np		<p>Noise Bypass Terminal</p> <p>Connect a bypass capacitor between GND.</p>
4	V _{OUT}		Output Terminal
5	V _{IN}		Input Terminal

8. Absolute Maximum Ratings

Parameter	Symbol	min	max	Unit	Condition
Supply Voltage	$V_{CC_{MAX}}$	-0.4	16	V	
Reverse Bias	$V_{rev_{MAX}}$	-0.4	6	V	$V_{out} \leq 2.0V$
		-0.4	12	V	$2.1V \leq V_{out}$
Np pin Voltage	$V_{np_{MAX}}$	-0.4	5	V	
Control pin Voltage	$V_{cont_{MAX}}$	-0.4	16	V	
Junction temperature	T_j	-	150	°C	
Storage Temperature Range	T_{stg}	-55	150	°C	
Power Dissipation	P_D	-	500	mW	When mounted on PCB (Note 1)

Note 1. Please do derating with 4.0mW/°C at $P_D=500mW$ and 25°C or more. Thermal resistance (θ_{JA}) = 250°C/W.

WARNING: The maximum ratings are the absolute limitation values with the possibility of the IC breakage. When the operation exceeds this standard quality cannot be guaranteed.

9. Recommended Operating Conditions

Parameter	Symbol	min	typ	max	Unit	Condition
Operating Temperature Range	T_a	-40	-	85	°C	
Operating Voltage Range	V_{OP}	2.1	-	14	V	

10. Electrical Characteristics

■ Electrical Characteristics of Ta=Tj=25°C

The parameters with min or max values will be guaranteed at Ta=Tj=25°C.

(Vin=Vout_{TYP}+1V, Vcont=1.8V, Ta=Tj=25°C)

Parameter	Symbol	Condition	min	typ	max	Unit
Output Voltage	Vout	Iout = 5mA	(Table 3, Table 4)			V
Line Regulation	LinReg	ΔVin = 5V	-	0.0	5.0	mV
Load Regulation	LoaReg	Iout = 5mA ~ 100mA	(Table 3, Table 4)			mV
		Iout = 5mA ~ 200mA				mV
Dropout Voltage (Note 2)	Vdrop	Iout = 50mA	-	80	140	mV
		Iout = 100mA	-	120	210	mV
		Iout = 180mA (2.1V ≤ Vout ≤ 2.3V)	-	230	350	mV
		Iout = 200mA (2.4V ≤ Vout)	-	200	350	mV
Maximum Output Current (Note 3)	Iout _{MAX}	Vout=Vout _{TYP} ×0.9	240	320	-	mA
Short Circuit Current (Note 3)	I _{SHORT}		-	360	-	mA
Quiescent Current	Iq	Iout = 0mA	-	63	100	μA
Standby Current	Istandby	Vcont = 0V	-	0.0	0.1	μA
Ground Pin Current	Ignd	Iout = 50mA	-	1.0	1.8	mA
Control Terminal						
Control Current	Icont	Vcont = 1.8V	-	5.0	15.0	μA
Control Voltage	Vcont	Vout ON state	1.8	-	-	V
		Vout OFF state	-	-	0.35	V

Note 2. For Vout ≤ 2.0V, no regulations.

Note 3. The maximum output current is limited by power dissipation.

Table 3. Standard Voltage Version

Part Number	Output Voltage			Load Regulation			
				Iout = 100mA		Iout = 200mA	
	MIN	TYP	MAX	MIN	TYP	TYP	MIN
V	V	V	V	V	mV	V	
AP1150ADS15	1.450	1.500	1.550	10	23	21	49
AP1150ADS18	1.750	1.800	1.850	10	24	22	51
AP1150ADS30	2.950	3.000	3.050	11	27	26	61
AP1150ADS33	3.250	3.300	3.350	12	28	27	64
AP1150ADS40	3.940	4.000	4.060	13	30	29	69
AP1150ADS45	4.432	4.500	4.568	13	31	31	73
AP1150ADS50	4.925	5.000	5.075	14	32	33	78
AP1150ADS54	5.319	5.400	5.481	14	33	34	81

Table 4. Optional Voltage Version

Part Number	Output Voltage			Load Regulation			
				Iout = 100mA		Iout = 200mA	
	MIN	TYP	MAX	MIN	TYP	TYP	MIN
	V	V	V	V	V	mV	V
AP1150ADS13	1.250	1.300	1.350	10	22	20	47
AP1150ADS14	1.350	1.400	1.450	10	22	20	48
AP1150ADS16	1.550	1.600	1.650	10	23	21	50
AP1150ADS17	1.650	1.700	1.750	10	23	21	51
AP1150ADS19	1.850	1.900	1.950	10	24	22	52
AP1150ADS20	1.950	2.000	2.050	10	24	22	53
AP1150ADS21	2.050	2.100	2.150	10	24	23	54
AP1150ADS22	2.150	2.200	2.250	11	25	23	55
AP1150ADS23	2.250	2.300	2.350	11	25	23	55
AP1150ADS24	2.350	2.400	2.450	11	25	24	56
AP1150ADS25	2.450	2.500	2.550	11	25	24	57
AP1150ADS26	2.550	2.600	2.650	11	26	24	58
AP1150ADS27	2.650	2.700	2.750	11	26	25	59
AP1150ADS28	2.750	2.800	2.850	11	26	25	60
AP1150ADS29	2.850	2.900	2.950	11	27	25	60
AP1150ADS31	3.050	3.100	3.150	12	27	26	62
AP1150ADS32	3.150	3.200	3.250	12	27	26	63
AP1150ADS34	3.349	3.400	3.451	12	28	27	64
AP1150ADS35	3.447	3.500	3.553	12	28	27	65
AP1150ADS36	3.546	3.600	3.654	12	28	28	66
AP1150ADS37	3.644	3.700	3.756	12	29	28	67
AP1150ADS38	3.743	3.800	3.857	12	29	29	68
AP1150ADS39	3.841	3.900	3.959	12	29	29	69
AP1150ADS41	4.038	4.100	4.162	13	30	30	70
AP1150ADS42	4.137	4.200	4.263	13	30	30	71
AP1150ADS43	4.235	4.300	4.365	13	30	30	72
AP1150ADS44	4.334	4.400	4.466	13	31	31	73
AP1150ADS46	4.531	4.600	4.669	13	31	31	74
AP1150ADS47	4.629	4.700	4.771	13	31	32	75
AP1150ADS48	4.728	4.800	4.872	14	32	32	76
AP1150ADS49	4.826	4.900	4.974	14	32	32	77
AP1150ADS51	5.023	5.100	5.177	14	33	33	78
AP1150ADS52	5.122	5.200	5.278	14	33	33	79
AP1150ADS53	5.220	5.300	5.380	14	33	34	80
AP1150ADS55	5.319	5.400	5.481	14	33	34	81
AP1150ADS60	5.910	6.000	6.090	15	35	36	86
AP1150ADS65	6.402	6.500	6.598	15	36	38	90
AP1150ADS70	6.895	7.000	7.105	16	38	39	94
AP1150ADS75	7.387	7.500	7.613	17	39	41	98
AP1150ADS80	7.880	8.000	8.120	17	40	43	102
AP1150ADS85	8.372	8.500	8.628	18	42	44	106
AP1150ADS90	8.865	9.000	9.136	18	43	46	110
AP1150ADS95	9.357	9.500	9.643	19	45	48	114

■ Electrical Characteristics of Ta=-40°C~85°C

The parameters with min or max values will be guaranteed at Ta=-40 ~ 85°C.

(Vin=Vout_{TYP}+1V, Vcont=1.8V, Ta=-40~85°C)

Parameter	Symbol	Condition	min	typ	Max	Unit
Output Voltage	Vout	Iout = 5mA	(Table 5, Table 6)			V
Line Regulation	LinReg	ΔVin = 5V	-	0.0	8.0	mV
Load Regulation	LoaReg	Iout = 5mA ~ 100mA	(Table 5, Table 6)			mV
		Iout = 5mA ~ 200mA				mV
Dropout Voltage (Note 4)	Vdrop	Iout = 50mA	-	80	180	mV
		Iout = 100mA	-	120	270	mV
		Iout = 180mA (2.2V ≤ Vout ≤ 2.3V)	-	230	390	mV
		Iout = 200mA (2.4V ≤ Vout)	-	200	390	mV
Maximum Output Current (Note 5)	Iout _{MAX}	Vout=Vout,typ × 0.9	220	320	-	mA
Short Circuit Current (Note 5)	ISHORT		-	360	-	mA
Quiescent Current	Iq	Iout = 0mA	-	63	120	μA
Standby Current	Istandby	Vcont = 0V	-	0.0	0.5	μA
Ground Pin Current	Ignd	Iout = 50mA	-	1.0	2.2	mA
Control Terminal						
Control Current	Icont	Vcont = 1.8V	-	5.0	15.0	μA
Control Voltage	Vcont	Vout ON state	1.8	-	-	V
		Vout OFF state	-	-	0.35	V

Note 4. For Vout ≤ 2.1V, no regulations.

Note 5. The maximum output current is limited by power dissipation.

Table 5. Standard Voltage Version

Part Number	Output Voltage			Load Regulation			
				Iout = 100mA		Iout = 200mA	
	MIN	TYP	MAX	MIN	TYP	TYP	MIN
	V	V	V	V	V	mV	V
AP1150ADS15	1.420	1.500	1.580	10	27	21	63
AP1150ADS18	1.720	1.800	1.880	10	28	22	63
AP1150ADS30	2.920	3.000	3.080	11	32	26	83
AP1150ADS33	3.217	3.300	3.383	12	33	27	88
AP1150ADS40	3.900	4.000	4.100	13	36	29	100
AP1150ADS45	4.387	4.500	4.613	13	38	31	109
AP1150ADS50	4.875	5.000	5.125	14	40	33	117
AP1150ADS54	5.265	5.400	5.535	14	41	34	124

Table 6. Optional Voltage Version

Part Number	Output Voltage			Load Regulation			
				Iout = 100mA		Iout = 200mA	
	MIN	TYP	MAX	MIN	TYP	TYP	MIN
	V	V	V	V	V	mV	V
AP1150ADS13	1.220	1.300	1.380	10	26	20	60
AP1150ADS14	1.320	1.400	1.480	10	26	20	61
AP1150ADS16	1.520	1.600	1.680	10	27	21	65
AP1150ADS17	1.620	1.700	1.780	10	28	21	61
AP1150ADS19	1.820	1.900	1.980	10	28	22	65
AP1150ADS20	1.920	2.000	2.080	10	29	22	66
AP1150ADS21	2.020	2.100	2.180	10	29	23	68
AP1150ADS22	2.120	2.200	2.280	11	29	23	70
AP1150ADS23	2.220	2.300	2.380	11	30	23	72
AP1150ADS24	2.320	2.400	2.480	11	30	24	73
AP1150ADS25	2.420	2.500	2.580	11	30	24	75
AP1150ADS26	2.520	2.600	2.680	11	31	24	77
AP1150ADS27	2.620	2.700	2.780	11	31	25	78
AP1150ADS28	2.720	2.800	2.880	11	32	25	80
AP1150ADS29	2.820	2.900	2.980	11	32	25	82
AP1150ADS31	3.020	3.100	3.180	12	33	26	85
AP1150ADS32	3.120	3.200	3.280	12	33	26	87
AP1150ADS34	3.315	3.400	3.485	12	34	27	90
AP1150ADS35	3.412	3.500	3.588	12	34	27	92
AP1150ADS36	3.510	3.600	3.690	12	34	28	93
AP1150ADS37	3.607	3.700	3.793	12	35	28	95
AP1150ADS38	3.705	3.800	3.895	12	35	29	97
AP1150ADS39	3.802	3.900	3.998	12	36	29	99
AP1150ADS41	3.997	4.100	4.203	13	36	30	102
AP1150ADS42	4.095	4.200	4.305	13	37	30	104
AP1150ADS43	4.192	4.300	4.408	13	37	30	105
AP1150ADS44	4.290	4.400	4.510	13	37	31	107
AP1150ADS46	4.485	4.600	4.715	13	38	31	110
AP1150ADS47	4.582	4.700	4.818	13	38	32	112
AP1150ADS48	4.680	4.800	4.920	14	39	32	114
AP1150ADS49	4.777	4.900	5.023	14	39	32	115
AP1150ADS51	4.972	5.100	5.228	14	40	33	119
AP1150ADS52	5.070	5.200	5.330	14	40	33	120
AP1150ADS53	5.167	5.300	5.433	14	41	34	122
AP1150ADS55	5.265	5.400	5.535	14	41	34	124
AP1150ADS60	5.850	6.000	6.150	15	43	36	134
AP1150ADS65	6.337	6.500	6.663	15	45	38	142
AP1150ADS70	6.825	7.000	7.175	16	47	39	151
AP1150ADS75	7.312	7.500	7.688	17	49	41	159
AP1150ADS80	7.800	8.000	8.200	17	50	43	168
AP1150ADS85	8.287	8.500	8.713	18	52	44	176
AP1150ADS90	8.775	9.000	9.225	18	54	46	185
AP1150ADS95	9.262	9.500	9.738	19	56	48	193

11. Description

11.1 DC Characteristics

■ Line Regulation

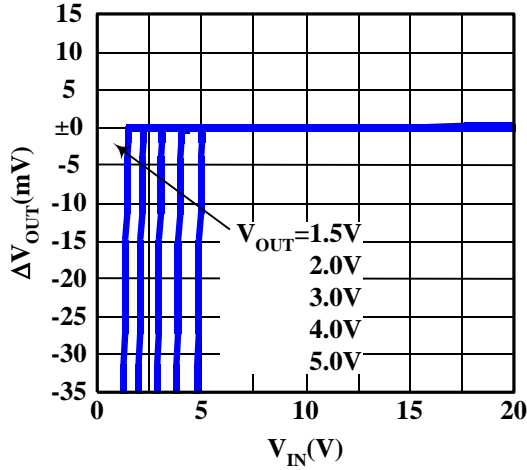

■ Load Regulation

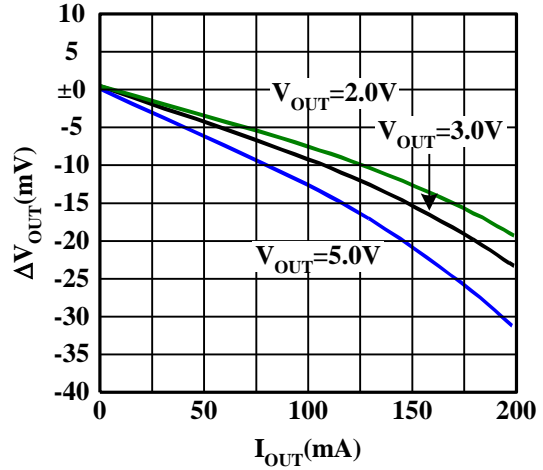

■ Stability Point

$I_{OUT}=0$ to 200mA

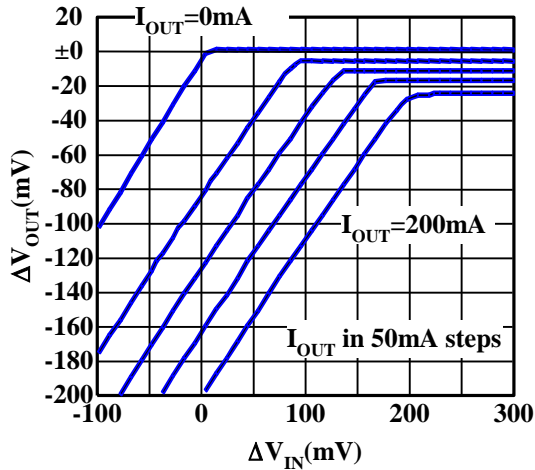

■ Dropout Voltage versus Output Current

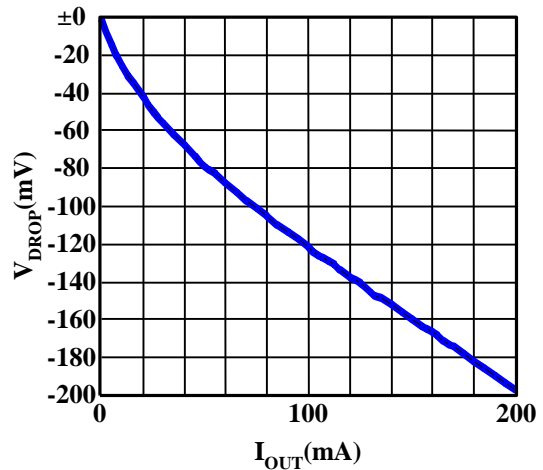

11.2 Input / output capacitors

Linear regulators require input and output capacitors in order to maintain the regulator's loop stability. The equivalent series resistance (ESR) of the output capacitor must be in the stable operation area. However, it is recommended to use as large a value of capacitance as is practical. The output noise and the ripple noise decrease as the capacitance value increases. ESR values vary widely between ceramic and tantalum capacitors. However, tantalum capacitors are assumed to provide more ESR damping resistance, which provides greater circuit stability. This implies that a higher level of circuit stability can be obtained by using tantalum capacitors when compared to ceramic capacitors with similar values.

For output voltage device $\geq 2.0V$ applications, the recommended value of $CL \geq 0.10\mu F$.

For output voltage device $\geq 1.5V$ applications, the recommended value of $CL \geq 0.22\mu F$

The input capacitor is necessary when the battery is discharged, the power supply impedance increases, or the line distance to the power supply is long. This capacitor might be necessary on each individual IC even if two or more regulator ICs are used. It is not possible to determine this indiscriminately. Please confirm the stability while mounted. The IC provides stable operation with an output side capacitor of 0.1μF (V_{OUT}≥2.0V). If it is 0.1μF or more over the full range of temperature, either a ceramic capacitor or tantalum capacitor can be used without considering ESR.

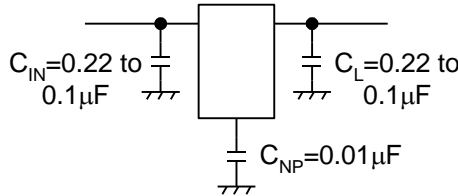
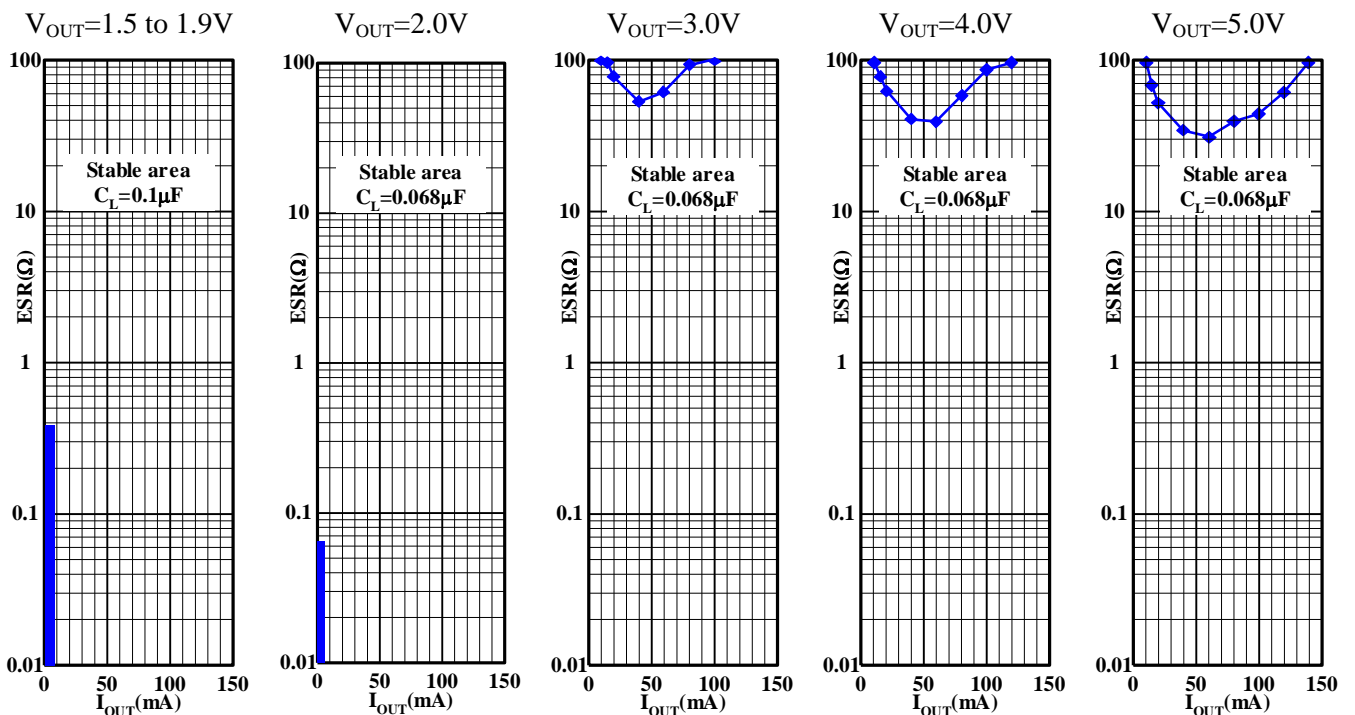

Figure 2. Recommended components values



All stable: C_L ≥ 0.22 μF All stable: C_L ≥ 0.1 μF

Figure 3. Stable operation area vs. voltage, current, and ESR

Note 6. Please increase the output capacitor value when the load current is 0.5 mA or less. The stability of the regulator improves if a big output side capacitor is used (the stable operation area extends.)

11.3 Bias voltage and temperature characteristics of the ceramic capacitor

Generally, a ceramic capacitor has both a temperature characteristic and a voltage characteristic. Please consider both characteristics when selecting the part. The B curves are the recommend characteristics.

■ Capacitance versus Voltage

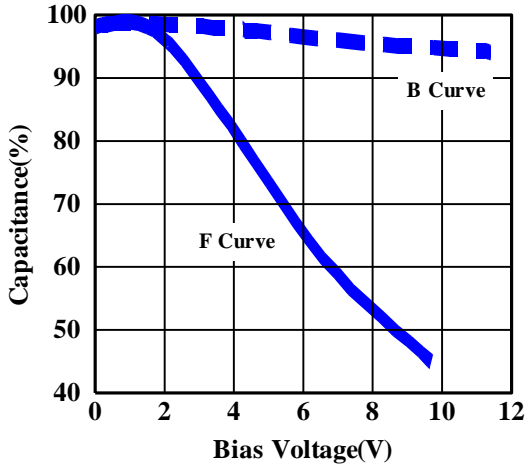

■ Capacitance versus Ambient Temperature

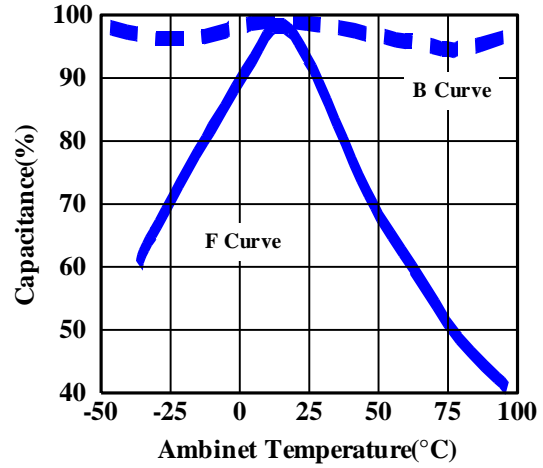

11.4 On/off control

It is recommended to turn the regulator off when the circuit following the regulator is non-operating. A design with little electric power loss can be implemented. We recommend the use of the on/off control of the regulator without using a high side switch to provide an output from the regulator. A highly accurate output voltage with low voltage drop is obtained.

Because the control current is small, it is possible to control it directly by CMOS logic.

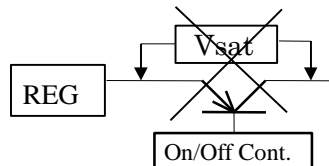

Figure 4. Equivalent circuit of output

11.5 Noise Bypass

The noise and the ripple rejection characteristics depend on the capacitance on the Np terminal. The ripple rejection characteristic of the low frequency region improves by increasing the capacitance of Cnp. A standard value is Cnp=0.001μF. Increase Cnp in a design with important output noise and ripple rejection requirements. The IC will not be damaged if the capacitor value is increased. The on/off switching speed changes depending on the Np terminal capacitance. The switching speed slows when the capacitance is large.

11.6 Board Layout

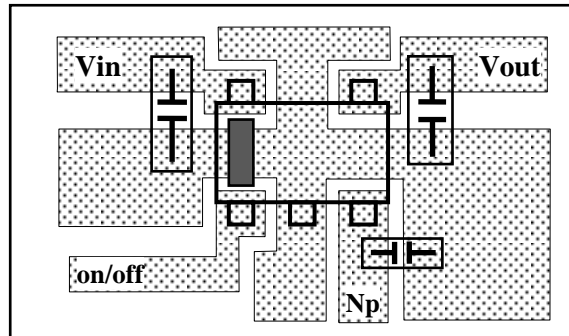

Figure 5. Layout (PCB Material: Glass epoxy (t=0.8mm))

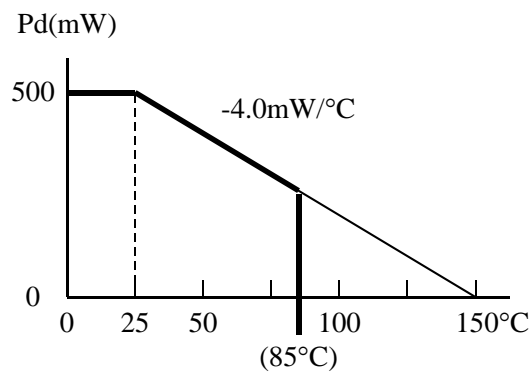

Figure 6. Derating curve

Please do derating with 4.0mW/°C at Pd=500mW and 25°C or more. Thermal resistance (θ_{ja}) is=250°C/W. The package loss is limited at the temperature that the internal temperature sensor works (about 150°C). Therefore, the package loss is assumed to be an internal limitation. There is no heat radiation characteristic of the package unit assumed because of the small size. The device being mounted on the PCB carries heat away. This value changes by the material and the copper pattern etc. of the PCB. The losses are approximately 500mW. Enduring these losses becomes possible in a lot of applications operating at 25°C. The overheating protection circuit operates when there are a lot of losses with the regulator (When outside temperature is high or heat radiation is bad). The output current cannot be pulled enough and the output voltage will drop when the protection circuit operates. When the junction temperature reaches 150°C, the IC is shut down. However, operation begins at once when the IC stops operation and the temperature of the chip decreases.

• How to determine the thermal resistance when mounted on PCB

The thermal resistance when mounted is expressed as follows:

$$T_j = \theta_{ja} \times P_d + T_a$$

T_j of IC is set around 150°C. P_d is the value when the thermal sensor is activated.

If the ambient temperature is 25°C, then:

$$150 = \theta_{ja} \times P_d + 25$$

$$\theta_{ja} = 125 / P_d \text{ (}^\circ\text{C / mW)}$$

• **The simple method to calculate Pd**

Mount the IC on the print circuit board. Short between the output pin and ground. after that, raise input voltage from 0V to evaluated voltage gradually. At shorted the output pin, the power dissipation P_D can be expressed as $P_d = V_{in} \times I_{in}$. The input current decreases gradually as the temperature of the chip becomes high. After a while, it reaches the thermal equilibrium. Use this current value at the thermal equilibrium. In almost all the cases, it shows 500mW or more. In the case that the power, $V_{in} \times \text{Short Circuit Current}$, becomes more than twice of the maximum rating of its power dissipation in a moment, there is a possibility that the IC is destroyed before internal thermal protection works.

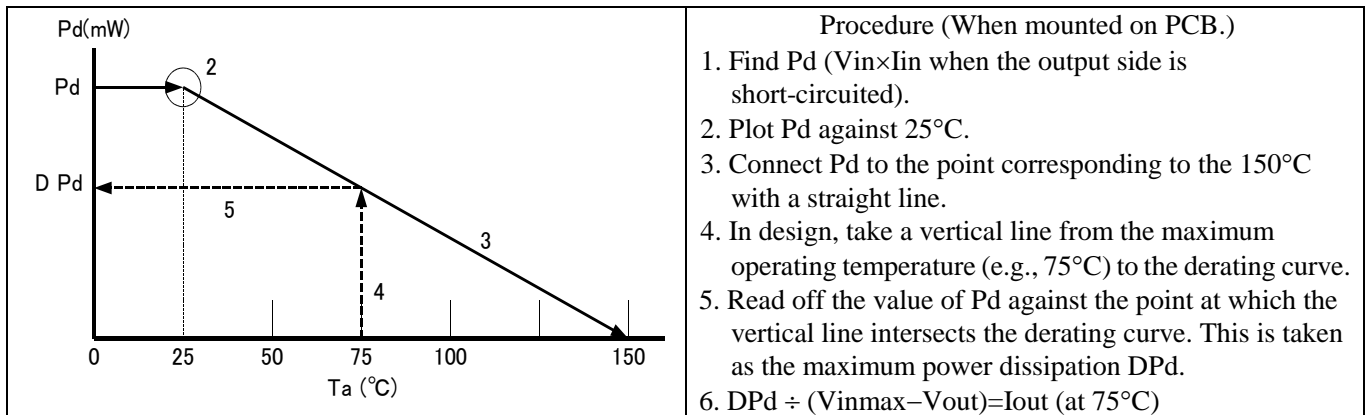

Figure 7. Determine Pd

The maximum output current at the highest operating temperature will be $I_{out} \cong D P_d \div (V_{inMax} - V_{out})$. Please use the device at low temperature with better radiation. The lower temperature provides better quality.

12. Definition of term

- **Output Voltage (Vout)**

The output voltage is specified with $V_{in}=(V_{out_TYP}+1V)$ and $I_{out}=5mA$.

- **Maximum Output Current (Iout MAX)**

The rated output current is specified under the condition where the output voltage drops 0.3V the value specified with $I_{out}=5mA$. The input voltage is set to $V_{out_TYP}+1V$ and the current is pulsed to minimize temperature effect.

- **Dropout Voltage (Vdrop)**

The dropout voltage is the difference between the input voltage and the output voltage at which point the regulator starts to fall out of regulation. Below this value, the output voltage will fall as the input voltage is reduced. It is dependent upon the load current and the junction temperature.

- **Line Regulation (LinReg)**

Line regulation is the ability of the regulator to maintain a constant output voltage as the input voltage changes. The line regulation is specified as the input voltage is changed from $V_{in}=V_{out_TYP}+1V$ to $V_{in}=V_{out_TYP}+6V$. It is a pulse measurement to minimize temperature effect.

- **Load Regulation (LoaReg)**

Load regulation is the ability of the regulator to maintain a constant output voltage as the load current changes. It is a pulsed measurement to minimize temperature effects with the input voltage set to $V_{in}=V_{out_TYP}+1V$. The load regulation is specified output current step conditions of 5mA to 100mA.

- **Ripple Rejection (R.R)**

Ripple rejection is the ability of the regulator to attenuate the ripple content of the input voltage at the output. It is specified with $200mV_{rms}$, 1kHz super-imposed on the input voltage, where $V_{in}=V_{out}+1.5V$. Ripple rejection is the ratio of the ripple content of the output vs. input and is expressed in dB.

- **Standby Current (Istandby)**

Standby current is the current, which flows into the regulator when the output is turned off by the control function ($V_{cont}=0V$).

- **Over Current Sensor**

The over current sensor protects the device when there is excessive output current. It also protects the device if the output is accidentally connected to ground.

- **Thermal Sensor**

The thermal sensor protects the device in case the junction temperature exceeds the safe value ($T_j=150^{\circ}C$). This temperature rise can be caused by external heat, excessive power dissipation caused by large input to output voltage drops, or excessive output current. The regulator will shut off when the temperature exceeds the safe value. As the junction temperatures decrease, the regulator will begin to operate again. Under sustained fault conditions, the regulator output will oscillate as the device turns off then resets. Damage may occur to the device under extreme fault.

Please reduce the loss of the regulator when this protection operate, by reducing the input voltage or make better heat efficiency. In the case that the power, $V_{in} \times I_{short}$ (Short Circuit Current), becomes more than twice of the maximum rating of its power dissipation in a moment, there is a possibility that the IC is destroyed before internal thermal protection works.

- **Reverse Voltage Protection**

Reverse voltage protection prevents damage due to the output voltage being higher than the input voltage. This fault condition can occur when the output capacitor remains charged and the input is reduced to zero, or when an external voltage higher than the input voltage is applied to the output side

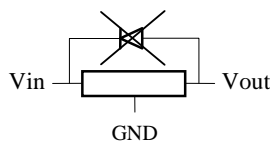

- **ESD**

MM: 200pF 0Ω 200V or more

HBM: 100pF 1.5kΩ 2000V or more

13. Recommended External Circuits

■ External Circuit

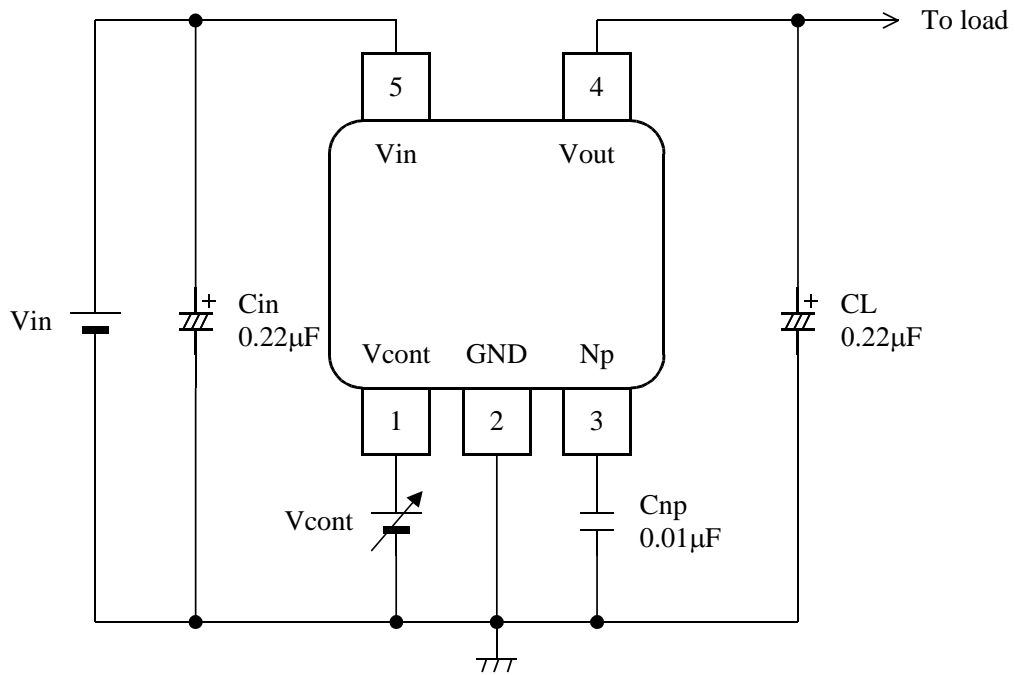

Figure 8. External Circuit

■ Test Circuit

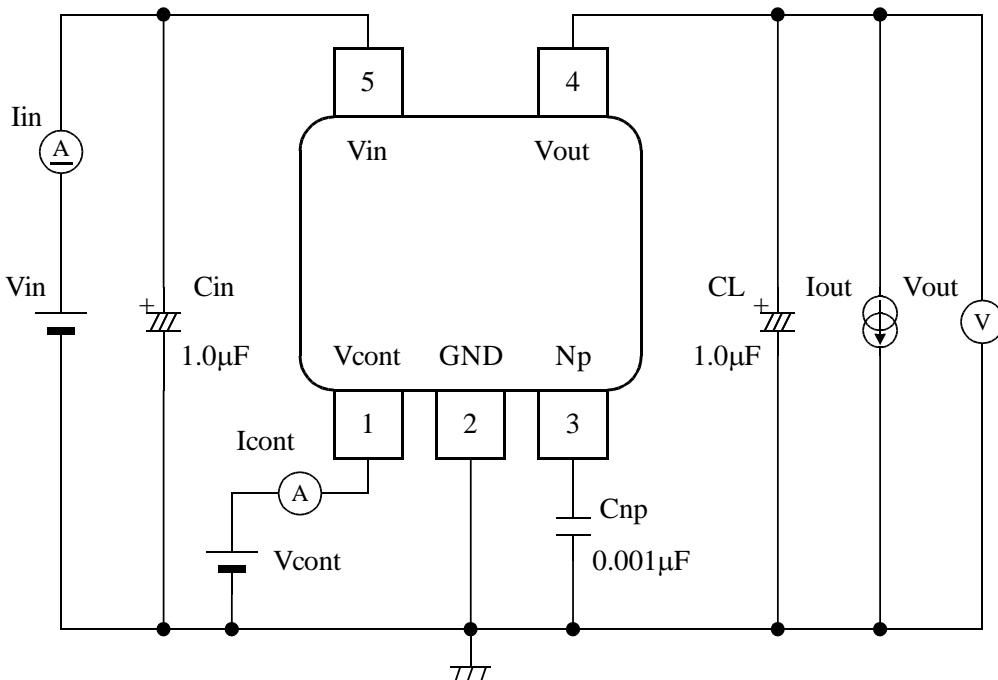

Figure 9. Test Circuit

Note 7. Electrical Characteristics are applied for the test circuit above.

($C_{in}=1.0\mu F$ (Tantalum) , $CL=1.0\mu F$ (Tantalum) , $C_{np}=0.001\mu F$ (Ceramic))In the application , both of ceramic capacitor and tantalum capacitor are available to use as C_{in} , CL and C_{np} at $I_{out} \geq 0.5mA$.

14. Package

■ **Outline Dimensions**

▪ Unit: mm

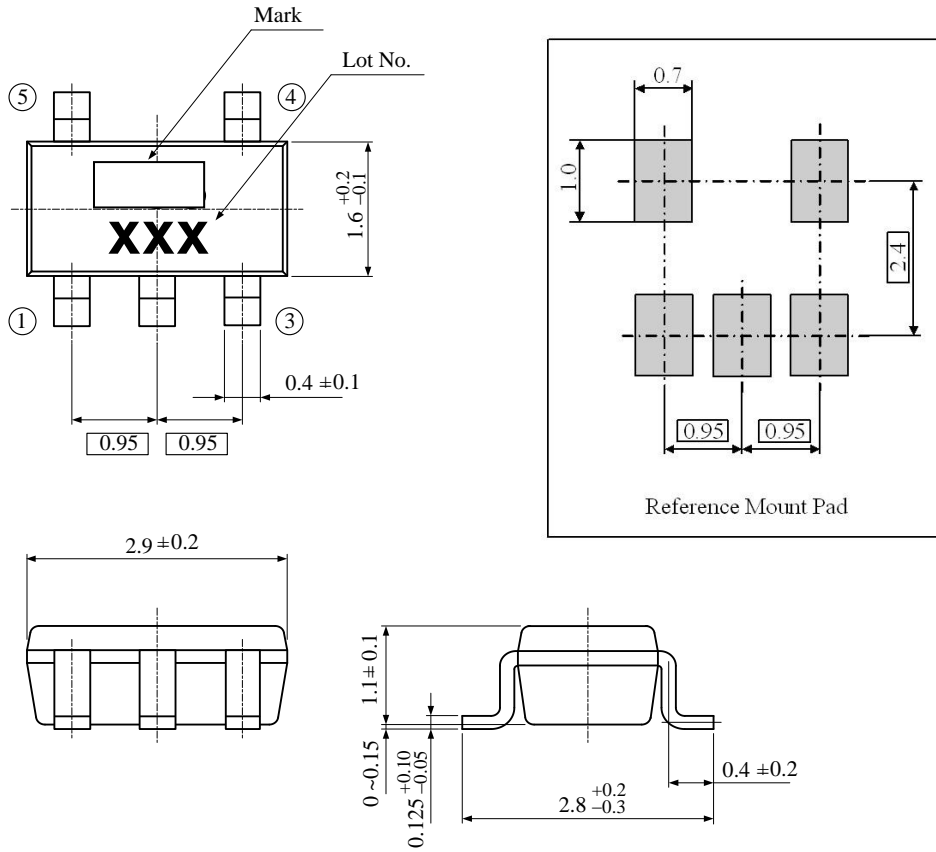

IMPORTANT NOTICE

0. Asahi Kasei Microdevices Corporation (“AKM”) reserves the right to make changes to the information contained in this document without notice. When you consider any use or application of AKM product stipulated in this document (“Product”), please make inquiries the sales office of AKM or authorized distributors as to current status of the Products.
1. All information included in this document are provided only to illustrate the operation and application examples of AKM Products. AKM neither makes warranties or representations with respect to the accuracy or completeness of the information contained in this document nor grants any license to any intellectual property rights or any other rights of AKM or any third party with respect to the information in this document. You are fully responsible for use of such information contained in this document in your product design or applications. **AKM ASSUMES NO LIABILITY FOR ANY LOSSES INCURRED BY YOU OR THIRD PARTIES ARISING FROM THE USE OF SUCH INFORMATION IN YOUR PRODUCT DESIGN OR APPLICATIONS.**
2. The Product is neither intended nor warranted for use in equipment or systems that require extraordinarily high levels of quality and/or reliability and/or a malfunction or failure of which may cause loss of human life, bodily injury, serious property damage or serious public impact, including but not limited to, equipment used in nuclear facilities, equipment used in the aerospace industry, medical equipment, equipment used for automobiles, trains, ships and other transportation, traffic signaling equipment, equipment used to control combustions or explosions, safety devices, elevators and escalators, devices related to electric power, and equipment used in finance-related fields. Do not use Product for the above use unless specifically agreed by AKM in writing.
3. Though AKM works continually to improve the Product’s quality and reliability, you are responsible for complying with safety standards and for providing adequate designs and safeguards for your hardware, software and systems which minimize risk and avoid situations in which a malfunction or failure of the Product could cause loss of human life, bodily injury or damage to property, including data loss or corruption.
4. Do not use or otherwise make available the Product or related technology or any information contained in this document for any military purposes, including without limitation, for the design, development, use, stockpiling or manufacturing of nuclear, chemical, or biological weapons or missile technology products (mass destruction weapons). When exporting the Products or related technology or any information contained in this document, you should comply with the applicable export control laws and regulations and follow the procedures required by such laws and regulations. The Products and related technology may not be used for or incorporated into any products or systems whose manufacture, use, or sale is prohibited under any applicable domestic or foreign laws or regulations.
5. Please contact AKM sales representative for details as to environmental matters such as the RoHS compatibility of the Product. Please use the Product in compliance with all applicable laws and regulations that regulate the inclusion or use of controlled substances, including without limitation, the EU RoHS Directive. AKM assumes no liability for damages or losses occurring as a result of noncompliance with applicable laws and regulations.
6. Resale of the Product with provisions different from the statement and/or technical features set forth in this document shall immediately void any warranty granted by AKM for the Product and shall not create or extend in any manner whatsoever, any liability of AKM.
7. This document may not be reproduced or duplicated, in any form, in whole or in part, without prior written consent of AKM.