

TPS50x01-xx 1.6- to 6.3-V Input, 3-A/6-A Synchronous Step-Down SWIFT™ Converter

1 Features

- Peak Efficiency: 95% ($V_O = 3.3\text{ V}$)
- Integrated 55-m Ω /50-m Ω MOSFETs
- Split Power Rail: 1.6 to 6.3 V on PVIN
- Power Rail: 3 to 6.3 V on VIN
- TPS50301-HT: 3 A
- TPS50601-SP: 6 A
- Flexible Switching Frequency Options:
 - 100-kHz to 1-MHz Adjustable Internal Oscillator
 - External Sync Capability: 100 kHz to 1 MHz
 - Sync Pin can be Configured as a 500-kHz Output for Master/Slave Applications
- 0.795-V \pm 1.258% Voltage Reference at 25°C
- Monotonic Start-Up into Prebiased Outputs
- Adjustable Slow Start and Power Sequencing
- Power Good Output Monitor for Undervoltage and Overvoltage
- Adjustable Input Undervoltage Lockout (UVLO)
- 20-Pin Thermally-Enhanced Ceramic Flatpack Package (HKH)
- See www.ti.com/swift for SWIFT™ Documentation
- 5962R10221:
 - Radiation Hardness Assurance (RHA) up to TID 100 krad (Si)
 - ELDRS Free 100 krad (Si) – 10 mRAD(Si)/s
 - Single Event Latchup (SEL) Immune to LET = 85 MeV-cm²/mg (See [Radiation Report](#))
 - SEB and SEGR Immune to 85 MeV-cm²/mg, SOA Curve Available (See [Radiation Report](#))
 - SET/SEFI Cross-Section Plot Available (See [Radiation Report](#))

2 Applications

- Point of Load Regulation
- TPS50601-SP: Rad Tolerant Applications
- TPS50301-HT: Down-Hole Drilling
- Supports Harsh Environment Applications
- TPS50301-HT Available in Extreme (–55°C to 210°C) Temperature Range
- TPS50601-SP Available in Military (–55°C to 125°C) Temperature Range ⁽¹⁾
- TPS50301-HT: TI's High Temperature Products use Highly-Optimized Silicon (Die) Solutions With Design and Process Enhancements to Maximize Performance over Extended Temperatures
- Engineering Evaluation (/EM) Samples are Available ⁽²⁾

3 Description

The TPS50301-HT is a 6.3-V, 3-A and the TPS50601-SP is a 6.3-V, 6-A synchronous step-down converter, which is optimized for small designs through high efficiency and integrating the high-side and low-side MOSFETs. Further space savings are achieved through current mode control, which reduces component count, and a high switching frequency, reducing the inductor's footprint. The devices are offered in a thermally enhanced 20-pin ceramic, dual in-line flatpack package.

Device Information⁽¹⁾

PART NUMBER	PACKAGE	BODY SIZE (NOM)
TPS50301-HT	CFP (20)	7.38 × 12.70 mm
TPS50601-SP	CFP (20)	7.38 × 12.70 mm
	KGD	N/A ⁽²⁾

(1) For all available packages, see the orderable addendum at the end of the data sheet.

(2) Bare die in wafer pack

Efficiency vs Load Current, Vin = 5 V

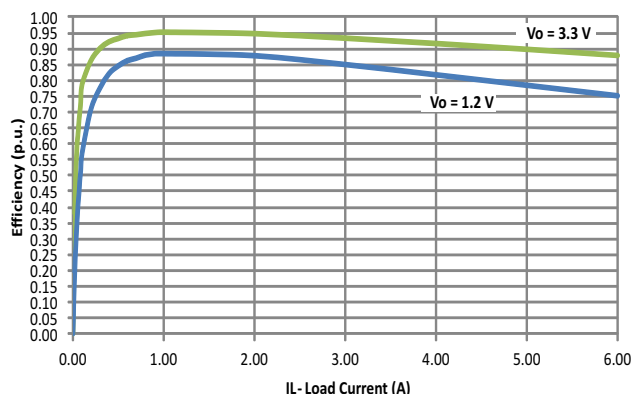

(1) Custom temperature ranges available

(2) These units are intended for engineering evaluation only. They are processed to a non-compliant flow (that is no burn-in, and so forth) and are tested to temperature rating of 25°C only. These units are not suitable for qualification, production, radiation testing or flight use. Parts are not warranted for performance on full MIL specified temperature range of –55°C to 125°C or operating life.



Table of Contents

1 Features	1	8.3 Feature Description.....	20
2 Applications	1	8.4 Device Functional Modes.....	31
3 Description	1	9 Application and Implementation	33
4 Revision History	2	9.1 Application Information.....	33
5 Description (continued)	3	9.2 Typical Application	33
6 Pin Configuration and Functions	4	10 Power Supply Recommendations	39
7 Specifications	8	11 Layout	39
7.1 Absolute Maximum Ratings	8	11.1 Layout Guidelines	39
7.2 ESD Ratings.....	8	11.2 Layout Example	40
7.3 Recommended Operating Conditions.....	8	12 Device and Documentation Support	41
7.4 Thermal Information	9	12.1 Documentation Support	41
7.5 Electrical Characteristics: TPS50301-HT.....	10	12.2 Related Links	41
7.6 Electrical Characteristics: TPS50601-SP.....	12	12.3 Community Resources.....	41
7.7 Dissipation Ratings	14	12.4 Trademarks	41
7.8 Typical Characteristics.....	16	12.5 Electrostatic Discharge Caution.....	41
8 Detailed Description	19	12.6 Glossary	41
8.1 Overview	19	13 Mechanical, Packaging, and Orderable Information	41
8.2 Functional Block Diagram	20		

4 Revision History

NOTE: Page numbers for previous revisions may differ from page numbers in the current version.

Changes from Revision G (December 2014) to Revision H	Page
• Updated backside potential to ground	5
• Updated bare die image	5
• Corrected test condition from "90% to 90%" to "10% to 90%"	11
• Added test conditions for 5962R1022102V9A part maximums	12
• Added information for the 5962R1022102V9A enable threshold, voltage reference, internally set frequency, minimum on time, and SS/TR to VSENSE matching	12
• Corrected test condition from "90% to 90%" to "10% to 90%"	13
• Updated hysteresis for VIN UVLO threshold to 50 mV typical	22
• Added parameter units to Equation 6	24
• Updated I _{ss} value to 2.5 μ A typical	36
• Updated Ontimemin for Equation 32 from "135" to "175" ns maximum	36

Changes from Revision F (November 2013) to Revision G	Page
• Added <i>ESD Ratings</i> table, <i>Feature Description</i> section, <i>Device Functional Modes</i> , <i>Application and Implementation</i> section, <i>Power Supply Recommendations</i> section, <i>Layout</i> section, <i>Device and Documentation Support</i> section, and <i>Mechanical, Packaging, and Orderable Information</i> section	1
• Added <i>Bare Die Information</i> and Bond Pad Coordinates in Microns table	5

Changes from Revision E (May 2013) to Revision F	Page
• Changed <i>Features</i> section	1

5 Description (continued)

The output voltage startup ramp is controlled by the SS/TR pin which allows operation as either a stand alone power supply or in tracking situations. Power sequencing is also possible by correctly configuring the enable and the open drain power good pins.

Cycle-by-cycle current limiting on the high-side FET protects the device in overload situations and is enhanced by a low-side sourcing current limit which prevents current runaway. There is also a low-side sinking current limit which turns off the low-side MOSFET to prevent excessive reverse current. Thermal shutdown disables the part when die temperature exceeds thermal shutdown temperature.

6 Pin Configuration and Functions

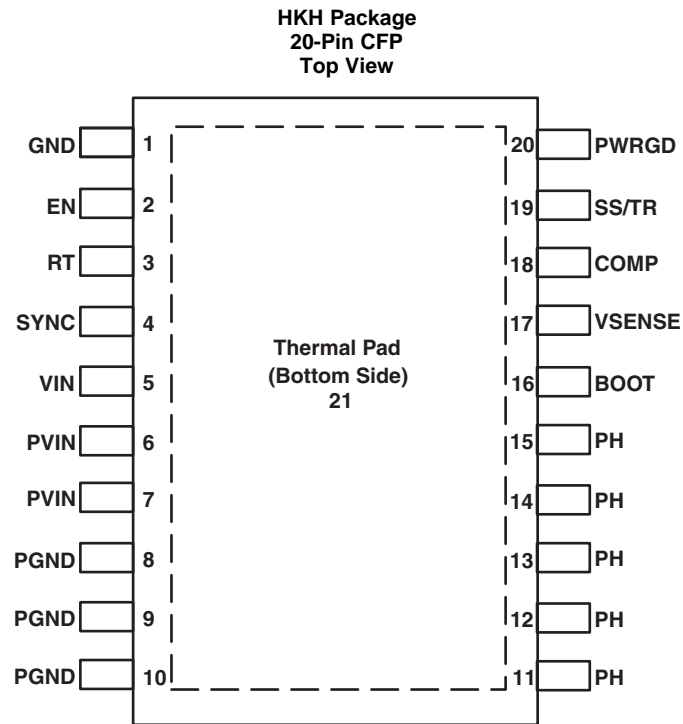

Pin Functions

PIN		DESCRIPTION
NO.	NAME	
1	GND	Return for control circuitry/thermal pad ⁽¹⁾
2	EN	Enable pin. Float to enable. Adjust the input undervoltage lockout (UVLO) with two resistors.
3	RT	In internal oscillation mode, a resistor is connected between the RT pin and GND to set the switching frequency.
4	SYNC	Optional 1-MHz external system clock input. The device operates with an internal oscillator if this pin is left open.
5	VIN	Supplies the power to the output FET controllers
6	PVIN	Power input. Supplies the power switches of the power converter
7		
8	PGND	Return for low-side power MOSFET
9		
10		
11	PH	Switch node
12		
13		
14		
15		
16	BOOT	A bootstrap capacitor is required between BOOT and PH. The voltage on this capacitor carries the gate drive voltage for the high-side MOSFET.
17	VSENSE	Inverting input of the gm error amplifier
18	COMP	Error amplifier output and input to the output switch current comparator. Connect frequency compensation to this pin.
19	SS/TR	Slow-start and tracking. An external capacitor connected to this pin sets the internal voltage reference rise time. The voltage on this pin overrides the internal reference. It can be used for tracking and sequencing.
20	PWRGD	Power Good fault pin. Asserts low if output voltage is low due to thermal shutdown, dropout, overvoltage, or EN shutdown, or during slow start.

(1) Thermal pad (analog ground) must be connected to PGND external to the package.

Bare Die Information

DIE THICKNESS	BACKSIDE FINISH	BACKSIDE POTENTIAL	BOND PAD METALLIZATION COMPOSITION	BOND PAD THICKNESS
15 mils.	Silicon with backgrind	Ground	Al5TiN	557.5 nm

TPS50301-HT, TPS50601-SP

SLVSA94H – DECEMBER 2012 – REVISED JULY 2015

www.ti.com

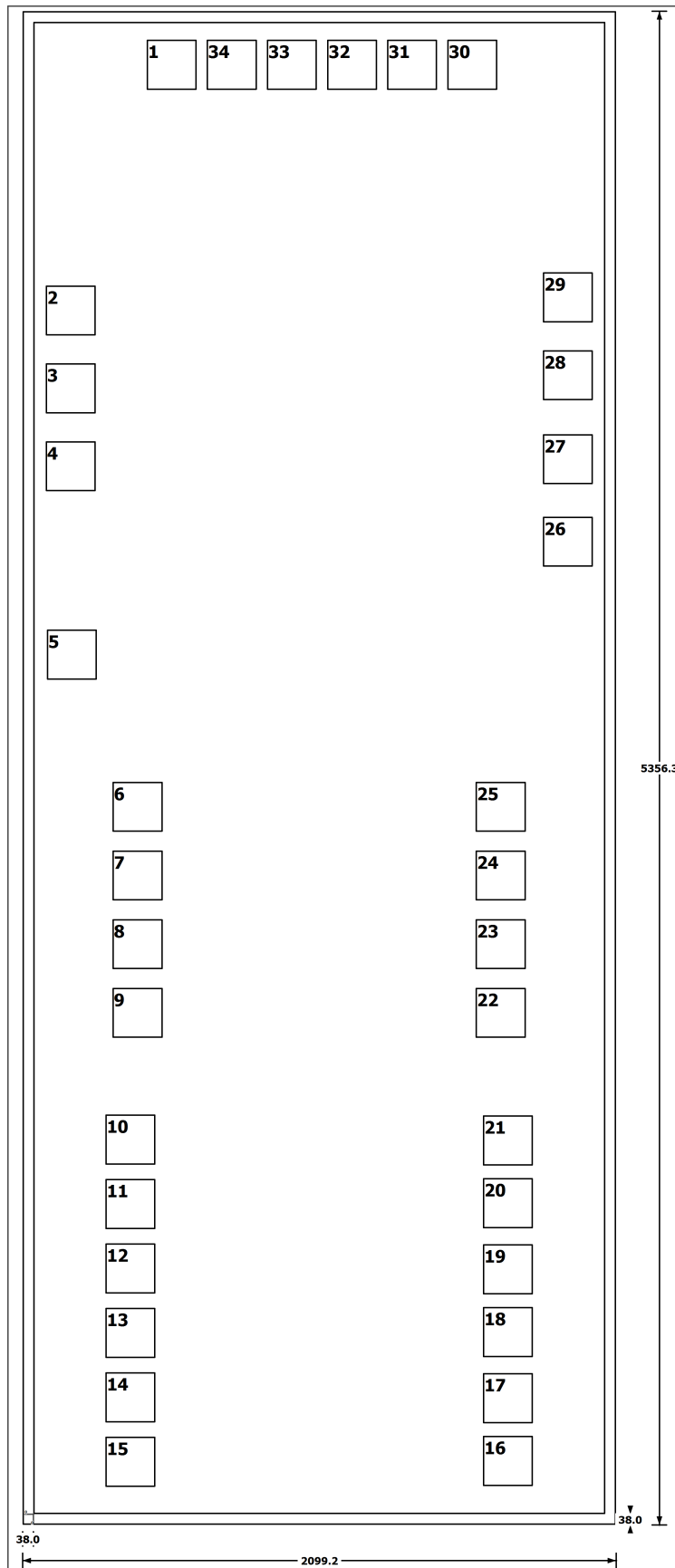

Bond Pad Coordinates in Microns

DESCRIPTION	PAD NUMBER	X MIN	Y MIN	X MAX	Y MAX
GND	1	400.77	5039.325	578.07	5216.625
EN	2	44.19	4169.79	221.49	4347.09
RT	3	44.19	3894.21	221.49	4071.51
SYNC	4	44.19	3618.63	221.49	3795.93
VIN	5	47.565	2952.27	224.865	3129.57
PVIN	6	280.215	2414.115	457.515	2591.415
PVIN	7	280.215	2170.665	457.515	2347.965
PVIN	8	280.215	1928.115	457.515	2105.415
PVIN	9	280.215	1684.665	457.515	1861.965
PGND	10	254.52	1236.285	431.82	1413.585
PGND	11	254.52	1008.315	431.82	1185.615
PGND	12	254.52	780.345	431.82	957.645
PGND	13	254.52	552.375	431.82	729.675
PGND	14	254.52	324.405	431.82	501.705
PGND	15	254.52	96.435	431.82	273.735
PH	16	1590.12	99.405	1767.42	276.705
PH	17	1590.12	321.435	1767.42	498.735
PH	18	1590.12	555.345	1767.42	732.645
PH	19	1590.12	777.375	1767.42	954.675
PH	20	1590.12	1011.285	1767.42	1188.585
PH	21	1590.12	1233.315	1767.42	1410.615
PH	22	1564.335	1684.665	1741.635	1861.965
PH	23	1564.335	1928.115	1741.635	2105.415
PH	24	1564.335	2170.665	1741.635	2347.965
PH	25	1564.335	2414.115	1741.635	2591.415
BOOT	26	1801.71	3352.14	1979.01	3529.44
VSENSE	27	1801.71	3644.145	1979.01	3821.445
COMP	28	1801.71	3940.92	1979.01	4118.22
SS/TR	29	1801.71	4216.5	1979.01	4393.8
PWRGD	30	1463.67	5039.325	1640.97	5216.625
GND	31	1251.09	5039.325	1428.39	5216.625
GND	32	1038.51	5039.325	1215.81	5216.625
GND	33	825.93	5039.325	1003.23	5216.625
GND	34	613.35	5039.325	790.65	5216.6

7 Specifications

7.1 Absolute Maximum Ratings

 over operating temperature (unless otherwise noted)⁽¹⁾

		MIN	MAX	UNIT	
Input voltage	VIN	-0.3	7	V	
	PVIN	-0.3	7		
	EN	-0.3	5.5		
	BOOT	-0.3	14		
	VSENSE	-0.3	3.3		
	COMP	-0.3	3.3		
	PWRGD	-0.3	5.5		
	SS/TR	-0.3	5.5		
	SYNC	-0.3	7		
Output voltage	BOOT-PH	0	7	V	
	PH	-1	7		
	PH 10-ns transient	-3	7		
Vdiff	(GND to exposed thermal pad)		-0.2	0.2	V
Output current	TPS50301-HT		3	A	
	TPS50601-SP		6		
Source current	PH	Current limit		A	
	RT	±100		µA	
Sink current	PH	Current limit		A	
	PVIN	Current limit		A	
	COMP	±200		µA	
	PWRGD	-0.1	5	mA	
Operating junction temperature	TPS50301-HT	-55	220	°C	
	TPS50601-SP	-55	150		
Storage temperature, T _{stg}	TPS50301-HT	-65	220	°C	
	TPS50601-SP	-65	150		

(1) Stresses beyond those listed under *Absolute Maximum Ratings* may cause permanent damage to the device. These are stress ratings only, which do not imply functional operation of the device at these or any other conditions beyond those indicated under *Recommended Operating Conditions*. Exposure to absolute-maximum-rated conditions for extended periods may affect device reliability.

7.2 ESD Ratings

			VALUE	UNIT
V _(ESD)	Electrostatic discharge	Human body model (HBM), per ANSI/ESDA/JEDEC JS-001, all pins ⁽¹⁾	±1000	V
		Charged device model (CDM), per JEDEC specification JESD22-C101, all pins ⁽²⁾	±1000	

(1) JEDEC document JEP155 states that 500-V HBM allows safe manufacturing with a standard ESD control process.

(2) JEDEC document JEP157 states that 250-V CDM allows safe manufacturing with a standard ESD control process.

7.3 Recommended Operating Conditions

over operating free-air temperature range (unless otherwise noted)

		MIN	NOM	MAX	UNIT	
T _J	junction operating temperature range	TPS50601-SP		-55	125	°C
		TPS50301-HT		-55	125	°C

7.4 Thermal Information

THERMAL METRIC ⁽¹⁾		TPS50x01-xx	UNIT
		HKH (CFP)	
		20 PINS	
R _{θJA}	Junction-to-ambient thermal resistance	39.929	°C/W
R _{θJB}	Junction-to-board thermal resistance	43.066	°C/W
ψ _{JT}	Junction-to-top characterization parameter	14.848	°C/W
ψ _{JB}	Junction-to-board characterization parameter	22.445	°C/W
R _{θJC(bot)}	Junction-to-case (bottom) thermal resistance	0.514	°C/W

(1) For more information about traditional and new thermal metrics, see the *Semiconductor and IC Package Thermal Metrics* application report, [SPRA953](#).

7.5 Electrical Characteristics: TPS50301-HT

 $T_J = -55^\circ\text{C}$ to 210°C , $V_{IN} = 3$ to 6.3 V, $PV_{IN} = 1.6$ to 6.3 V (unless otherwise noted)

PARAMETER	TEST CONDITIONS	MIN	TYP	MAX	UNIT	
SUPPLY VOLTAGE (VIN AND PVIN PINS)						
PVIN operating input voltage		1.6		6.3	V	
VIN operating input voltage		3		6.3	V	
VIN internal UVLO threshold	V_{IN} rising		2.75	3	V	
VIN internal UVLO hysteresis			50		mV	
VIN shutdown supply current	$EN = 0$ V		2.5	8	mA	
VIN operating – non-switching supply current	$V_{SENSE} = V_{BG}$		5	10	mA	
ENABLE AND UVLO (EN PIN)						
Enable threshold	Rising		1.13	1.19	V	
Enable threshold	Falling	0.97	1.03		V	
Input current	$V_{EN} = 1.1$ V		3.2		μA	
Hysteresis current	$V_{EN} = 1.3$ V		3		μA	
VOLTAGE REFERENCE						
Voltage reference	$0 \text{ A} \leq I_{out} \leq 3 \text{ A}$	-55°C	0.767	0.795	0.805	V
		25°C	0.785	0.795	0.805	
		210°C	0.785	0.795	0.830	
MOSFET						
High-side switch resistance	BOOT-PH = 2.2 V		55		m Ω	
High-side switch resistance ⁽¹⁾⁽²⁾	BOOT-PH = 6.3 V		50		m Ω	
Low-side switch resistance ⁽¹⁾⁽²⁾	$V_{IN} = 3$ V		50		m Ω	
ERROR AMPLIFIER						
Error amplifier transconductance (gm) ⁽²⁾	$-2 \mu\text{A} < I_{COMP} < 2 \mu\text{A}$, $V_{(COMP)} = 1$ V		1300		μS	
Error amplifier dc gain ⁽²⁾	$V_{SENSE} = 0.8$ V		39000		V/V	
Error amplifier source/sink ⁽²⁾	$V_{(COMP)} = 1$ V, 40 mV input overdrive		± 125		μA	
Start switching threshold ⁽²⁾			0.25		V	
COMP to Iswitch gm ⁽²⁾			18		A/V	
CURRENT LIMIT						
High-side switch current limit threshold	$V_{IN} = 6.3$ V	7.8	11		A	
Low-side switch sourcing current limit	$V_{IN} = 6.3$ V	6	10		A	
Low-side switch sinking current limit	$V_{IN} = 6.3$ V		3		A	
INTERNAL SWITCHING FREQUENCY						
Internally set frequency	RT = Open	395	500	585	kHz	
Externally set frequency	RT = 100 k Ω (1%)		480			
	RT = 485 k Ω (1%)		100			
	RT = 47 k Ω (1%)		1000			
EXTERNAL SYNCHRONIZATION						
SYNC out low-to-high rise time (10%/90%)	Clload = 25 pF		25	126	ns	
SYNC out high-to-low fall time (90%/10%)	Clload = 25 pF		3	15	ns	
Falling edge delay time ⁽³⁾			180		°	
SYNC out high-level threshold	$I_{OH} = 50 \mu\text{A}$	2			V	
SYNC out low-level threshold	$I_{OL} = 50 \mu\text{A}$			600	mV	
SYNC in low-level threshold		800			mV	
SYNC in high-level threshold				1.85	V	

(1) Measured at pins

(2) Ensured by design only. Not tested in production.

(3) Bench verified. Not tested in production.

Electrical Characteristics: TPS50301-HT (continued)
 $T_J = -55^{\circ}\text{C}$ to 210°C , $V_{IN} = 3$ to 6.3 V, $PV_{IN} = 1.6$ to 6.3 V (unless otherwise noted)

PARAMETER	TEST CONDITIONS	MIN	TYP	MAX	UNIT
SYNC in frequency range	Percent of program frequency	-5%		5%	
		100		1000	kHz
PH (PH PIN)					
Minimum on time	Measured at 10% to 90% of V_{IN} , 25°C , $I_{PH} = 2$ A		94	236	ns
Minimum off time	$BOOT-PH \geq 2.2$ V		500		ns
BOOT (BOOT PIN)					
BOOT-PH UVLO			2.2	3	V
SLOW START AND TRACKING (SS/TR PIN)					
SS charge current			2.5		μA
SS/TR to V_{SENSE} matching	$V_{(SS/TR)} = 0.4$ V		30	90	mV
POWER GOOD (PWRGD PIN)					
V_{SENSE} threshold	V_{SENSE} falling (fault)		91		% V_{ref}
	V_{SENSE} rising (good)		94		% V_{ref}
	V_{SENSE} rising (fault)		109		% V_{ref}
	V_{SENSE} falling (good)		106		% V_{ref}
Output high leakage	$V_{SENSE} = V_{ref}$, $V_{(PWRGD)} = 5$ V		0.03	2.9	μA
Output low	$I_{(PWRGD)} = 2$ mA			0.3	V
Minimum V_{IN} for valid output	$V_{(PWRGD)} < 0.5$ V at 100 μA		0.6	1	V
Minimum SS/TR voltage for PWRGD				1.4	V

7.6 Electrical Characteristics: TPS50601-SP

 $T_J = -55^\circ\text{C}$ to 125°C , $V_{IN} = 3\text{ V}$ to 6.3 V , $P_{VIN} = 1.6\text{ V}$ to 6.3 V (unless otherwise noted)

PARAMETER	TEST CONDITIONS		MIN	TYP	MAX	UNIT
SUPPLY VOLTAGE (VIN AND PVIN PINS)						
PVIN operating input voltage			1.6		6.3	V
VIN operating input voltage			3		6.3	V
VIN internal UVLO threshold	VIN rising			2.75	3	V
		5962R1022102V9A		2.75	3.01	
VIN internal UVLO hysteresis				50		mV
VIN shutdown supply current	VEN = 0 V			2.5	5.9	mA
VIN operating – non switching supply current	VSENSE = VBG			5	10	mA
ENABLE AND UVLO (EN PIN)						
Enable threshold	Rising			1.13	1.18	V
		5962R1022102V9A		1.13	1.19	
	Falling		1.05	1.09		
		5962R1022102V9A	1.03	1.09		
Input current	VEN = 1.1 V			3.2		μA
Hysteresis current	VEN = 1.3 V			3		μA
VOLTAGE REFERENCE						
Voltage reference	0 A ≤ Iout ≤ 6 A	-55°C	0.767	0.795	0.804	V
		25°C	0.785	0.795	0.804	
		125°C	0.785	0.795	0.815	
	5962R1022102V9A only 0 A ≤ Iout ≤ 6 A	-55°C	0.757	0.795	0.804	V
		25°C	0.782	0.795	0.808	
		125°C	0.785	0.795	0.816	
MOSFET						
High-side switch resistance	BOOT-PH = 2.2 V			55		mΩ
High-side switch resistance ⁽¹⁾	BOOT-PH = 6.3 V			50		mΩ
Low-side switch resistance ⁽¹⁾	VIN = 6.3 V			50		mΩ
ERROR AMPLIFIER						
Error amplifier transconductance (gm) ⁽²⁾	-2 μA < ICOMP < 2 μA, V(COMP) = 1 V			1300		μS
Error amplifier dc gain ⁽²⁾	VSENSE = 0.792 V			39000		V/V
Error amplifier source/sink ⁽²⁾	V(COMP) = 1 V, 40-mV input overdrive			±125		μA
Start switching threshold ⁽²⁾				0.25		V
COMP to Iswitch gm ⁽²⁾				18		A/V
CURRENT LIMIT						
High-side switch current limit threshold ⁽³⁾	VIN = 6.3 V		8	11		A
Low-side switch sourcing current limit ⁽³⁾	VIN = 6.3 V		7	10		A
Low-side switch sinking current limit	VIN = 6.3 V			3		A
THERMAL SHUTDOWN						
Thermal shutdown				175		°C
Thermal shutdown hysteresis				10		°C
INTERNAL SWITCHING FREQUENCY						
Internally set frequency	RT = Open		395	500	585	kHz
		5962R1022102V9A	368	500	585	

(1) Measured at pins

(2) Ensured by design only. Not tested in production.

(3) Parameter is specified by characterization for KGD and is not tested in production.

Electrical Characteristics: TPS50601-SP (continued)
 $T_J = -55^\circ\text{C}$ to 125°C , $V_{IN} = 3\text{ V}$ to 6.3 V , $P_{VIN} = 1.6\text{ V}$ to 6.3 V (unless otherwise noted)

PARAMETER	TEST CONDITIONS	MIN	TYP	MAX	UNIT
Externally set frequency	RT = 100 k Ω (1%)		480		kHz
	RT = 485 k Ω (1%)		100		
	RT = 47 k Ω (1%)		1000		
EXTERNAL SYNCHRONIZATION					
SYNC out low-to-high rise time (10%/90%)	Load = 25 pF		25	111	ns
SYNC out high-to-low fall time (90%/10%)	Load = 25 pF		3	15	ns
		5962R1022102V9A	3	21	
Falling edge delay time ⁽⁴⁾			180		°
SYNC out high level threshold	I _{OH} = 50 μ A	2			V
SYNC out low level threshold	I _{OL} = 50 μ A			600	mV
SYNC in low level threshold		800			mV
SYNC in high level threshold				1.85	V
SYNC in frequency range ⁽⁵⁾	Percent of program frequency		-5%	5%	
			100	1000	kHz
PH (PH PIN)					
Minimum on time	Measured at 10% to 90% of V _{IN} , 25°C, I _{PH} = 2 A		94	175	ns
		5962R1022102V9A	94	190	
Minimum off time	BOOT-PH \geq 3 V		500		ns
BOOT (BOOT PIN)					
BOOT-PH UVLO			2.2	3	V
SLOW START AND TRACKING (SS/TR PIN)					
SS charge current			2.5		μ A
SS/TR to VSENSE matching	V _(SS/TR) = 0.4 V		30	90	mV
		5962R1022102V9A	30	105	
POWER GOOD (PWRGD PIN)					
VSENSE threshold	V _{SENSE} falling (fault)		91		% V _{ref}
	V _{SENSE} rising (good)		94		% V _{ref}
	V _{SENSE} rising (fault)		109		% V _{ref}
	V _{SENSE} falling (good)		106		% V _{ref}
Output high leakage	V _{SENSE} = V _{ref} , V(PWRGD) = 5 V		30	181	nA
Output low	I _(PWRGD) = 2 mA			0.3	V
Minimum V _{IN} for valid output	V _(PWRGD) < 0.5 V at 100 μ A		0.6	1	V
Minimum SS/TR voltage for PWRGD				1.4	V

(4) Bench verified. Not tested in production.

(5) Parameter is specified by characterization for KGD and production tested at nominal voltage with $V_{IN} = P_{VIN} = 5\text{V}$.

7.7 Dissipation Ratings

See (1)(2)(3)(4)(5)

PACKAGE	$R_{\theta JA}$ THERMAL IMPEDANCE, JUNCTION TO AMBIENT	$R_{\theta JC}$ THERMAL IMPEDANCE, JUNCTION TO CASE (THERMAL PAD)	$R_{\theta JB}$ THERMAL IMPEDANCE, JUNCTION TO BOARD
HKH	39.9°C/W	0.52°C/W	43.1°C/W

- (1) Maximum power dissipation may be limited by overcurrent protection
- (2) Power rating at a specific ambient temperature, T_A , should be determined with a junction temperature of 150°C. This is the point where distortion starts to substantially increase. Thermal management of the PCB should strive to keep the junction temperature at or below 150°C for best performance and long-term reliability. See power dissipation estimate in [Application and Implementation](#) for more information.
- (3) Test board conditions:
 - (a) 2.5 inches x 2.5 inches, 4 layers, thickness: 0.062 inch
 - (b) 2-oz. copper traces located on the top of the PCB
 - (c) 2-oz. copper ground planes on the 2 internal layers and bottom layer
 - (d) 40.010-inch thermal vias located under the device package
- (4) For information on thermal characteristics, see [SPRA953](#).
- (5) For TPS50301-HT, use polyimide PCB and thermal management to ensure operation below maximum T_J operation.

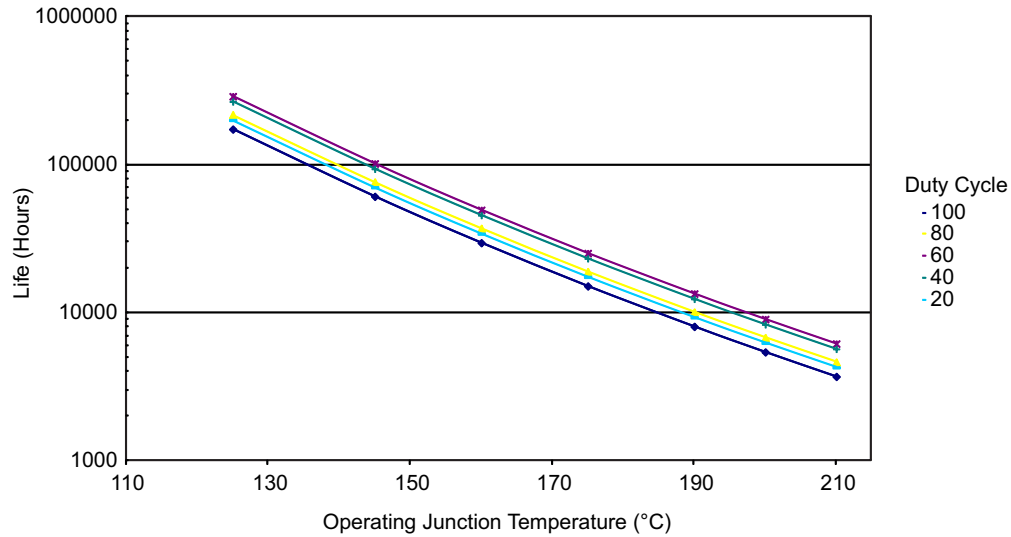

- A. See data sheet for absolute maximum and minimum recommended operating conditions.
- B. Silicon operating life design goal is 10 years at 125°C junction temperature (does not include package interconnect life).
- C. The predicted operating lifetime versus junction temperature is based on reliability modeling using electromigration as the dominant failure mechanism affecting device wearout for the specific device process and design characteristics.
- D. This device is rated for 1000 hours of continuous operation at maximum rated temperature at 210°C.

Figure 1. TPS50301-HT 3-A Continuous Current Estimated Device Life

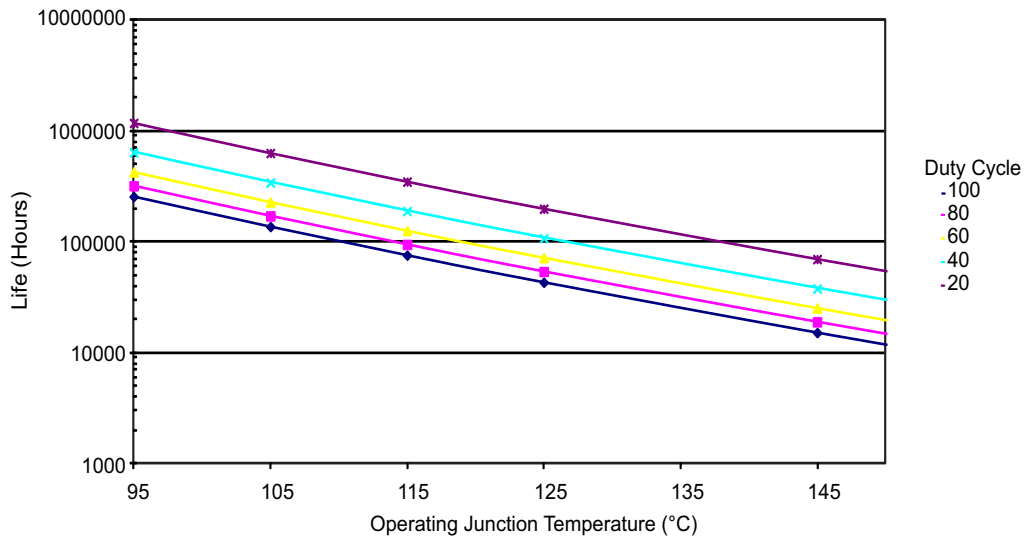

- A. See data sheet for absolute maximum and minimum recommended operating conditions.
- B. Product operating life design goal is >15 years for 65°C ≤ T_J ≤ 95°C based on silicon technology characterization per MIL-PRF-38535.
- C. The predicted operating lifetime versus junction temperature is based on reliability modeling using electromigration as the dominant failure mechanism affecting device wearout for the specific device process and design characteristics.

Figure 2. TPS50601-SP 6-A Continuous Current Estimated Device Life

7.8 Typical Characteristics

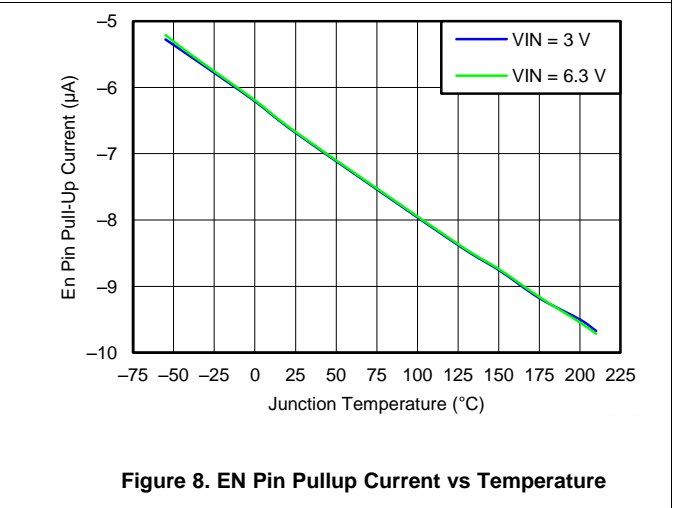
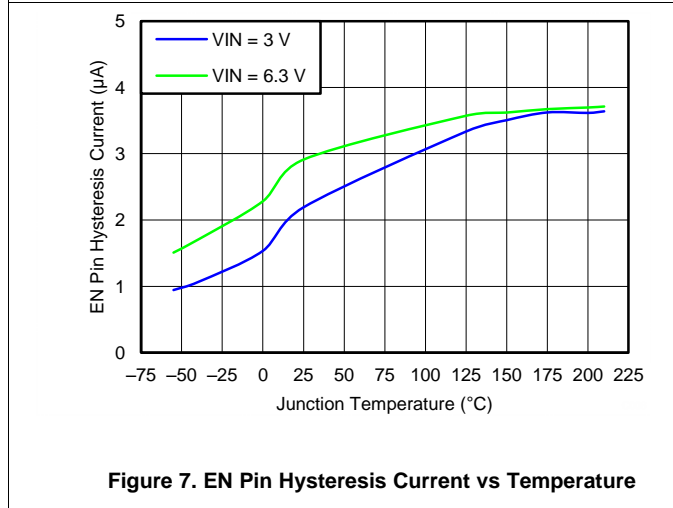
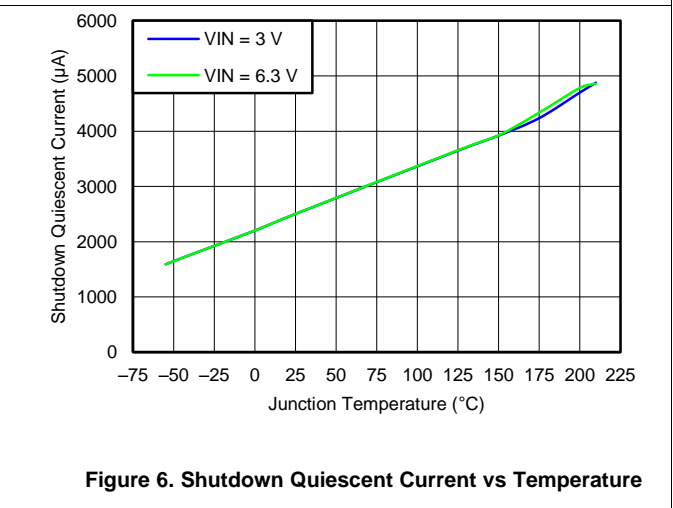
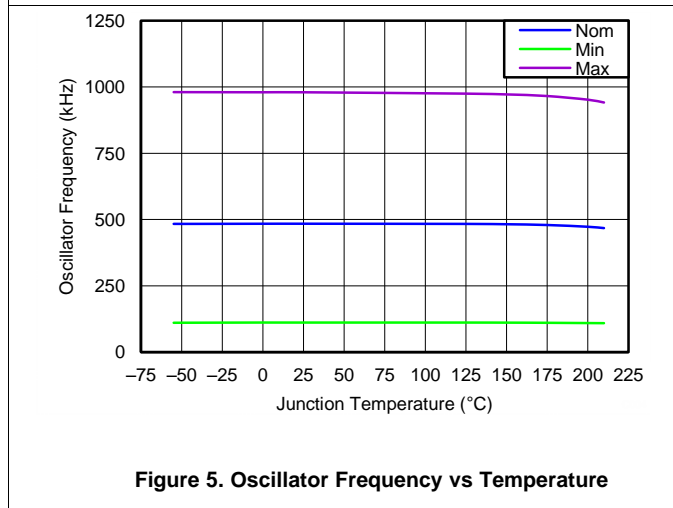
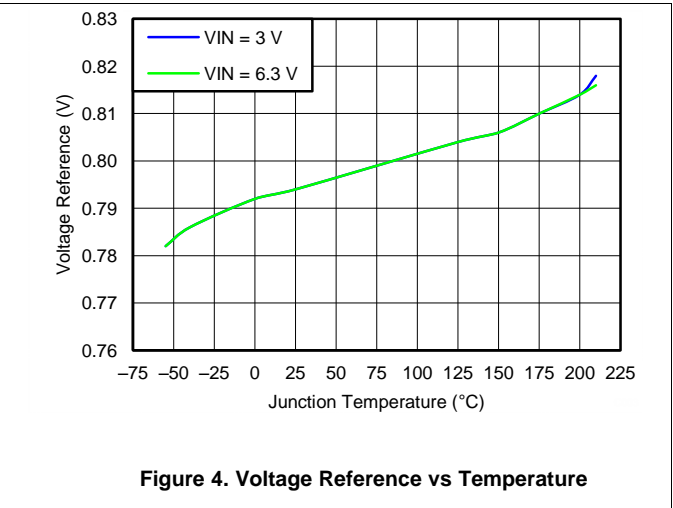
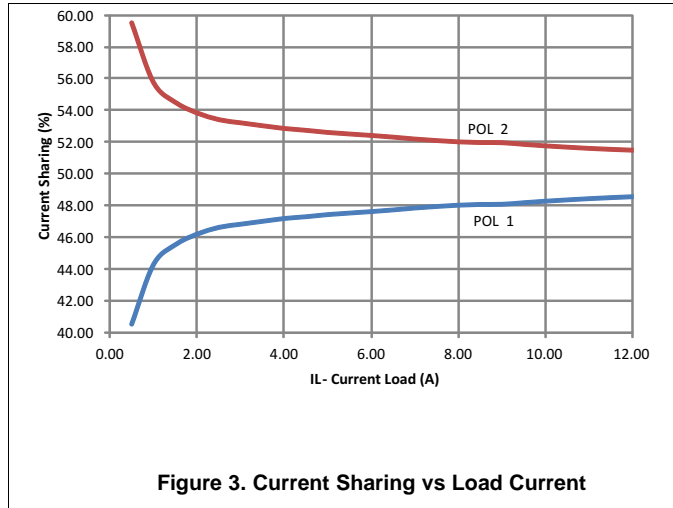

Typical Characteristics (continued)

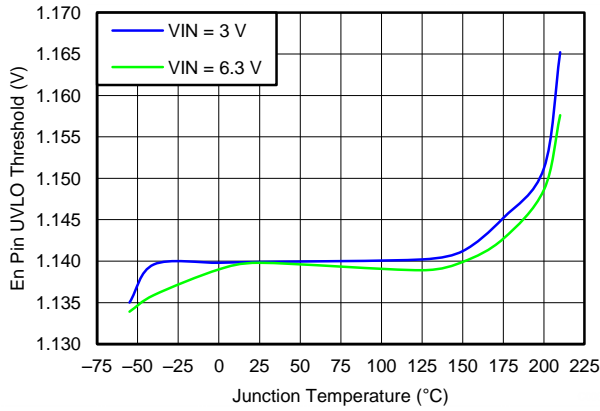

Figure 9. EN Pin UVLO Threshold vs Temperature

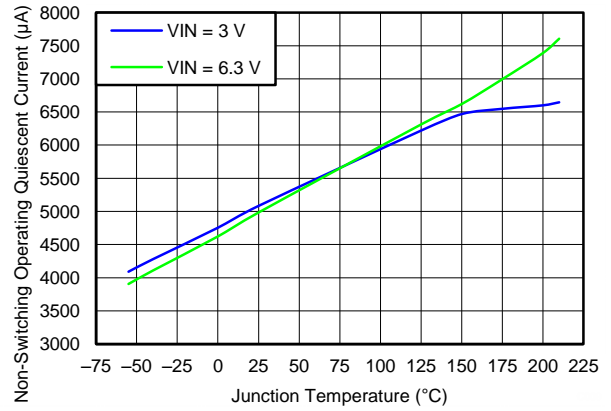

Figure 10. Non-Switching Operating Quiescent Current (VIN) vs Temperature

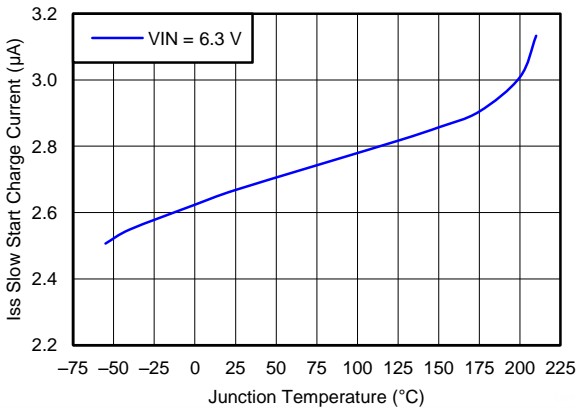

Figure 11. Slow Start Charge Current vs Temperature

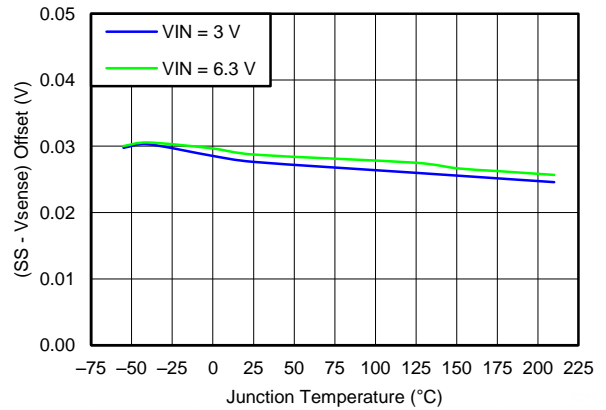

Figure 12. (SS - V_{SENSE}) Offset vs Temperature

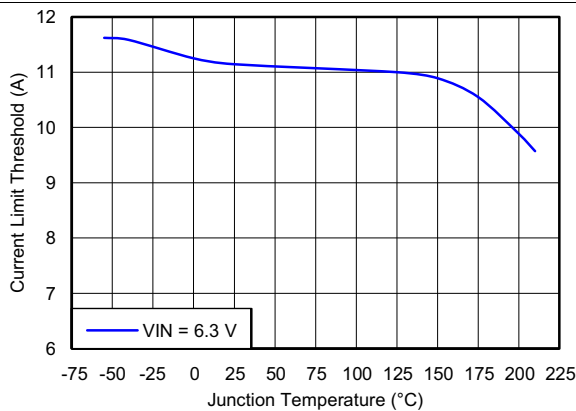

Figure 13. High-Side Current Limit Threshold vs Temperature

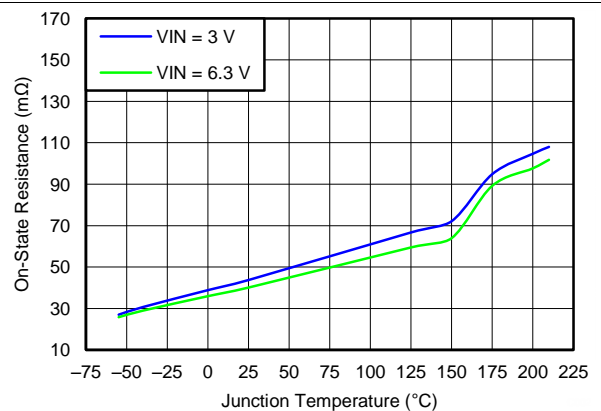

Figure 14. Low-Side R_{DS(on)} vs Temperature

Typical Characteristics (continued)

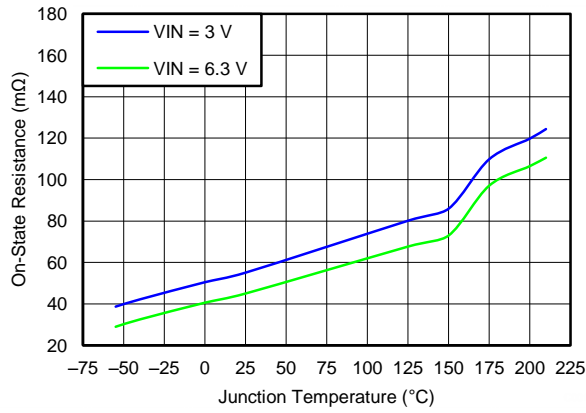

Figure 15. High-Side $R_{DS(on)}$ vs Temperature

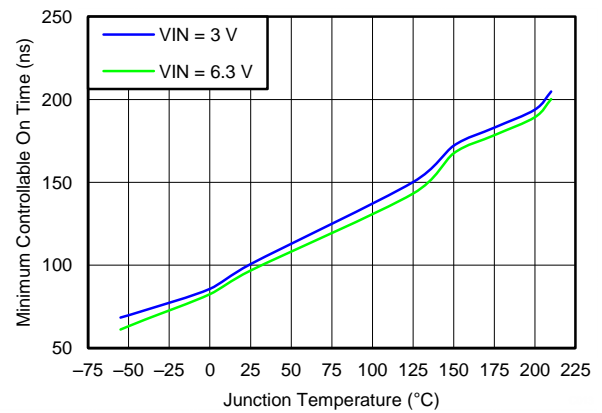

Figure 16. Minimum Controllable On-Time vs Temperature

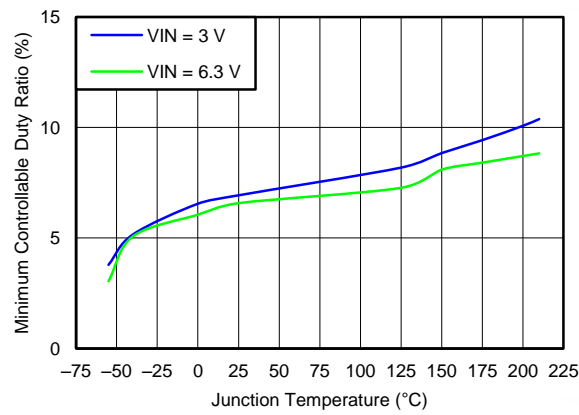

Figure 17. Minimum Controllable Duty Ratio vs Temperature

8 Detailed Description

8.1 Overview

The device is a 6.3-V, 3-A or 6-A, synchronous step-down (buck) converter with two integrated N-channel MOSFETs. To improve performance during line and load transients, the device implements a constant frequency, peak current mode control, which also simplifies external frequency compensation. The wide switching frequency, 100 kHz to 1 MHz, allows for efficiency and size optimization when selecting the output filter components.

The device is designed for safe monotonic startup into prebiased loads. The default start up is when VIN is typically 3 V. The EN pin has an internal pullup current source that can be used to adjust the input voltage UVLO with two external resistors. In addition, the EN pin can be floating for the device to operate with the internal pullup current. The total operating current for the device is approximately 5 mA when not switching and under no load. When the device is disabled, the supply current is typically less than 2.5 mA.

The integrated MOSFETs allow for high-efficiency power supply designs with continuous output currents up to 6 A. The MOSFETs have been sized to optimize efficiency for lower duty cycle applications.

The device reduces the external component count by integrating the boot recharge circuit. The bias voltage for the integrated high-side MOSFET is supplied by a capacitor between the BOOT and PH pins. The boot capacitor voltage is monitored by a BOOT to PH UVLO (BOOT-PH UVLO) circuit allowing the PH pin to be pulled low to recharge the boot capacitor. The device can operate over duty cycle range per [Equation 2](#) and [Equation 3](#) as long as the boot capacitor voltage is higher than the preset BOOT-PH UVLO threshold, which is typically 2.2 V. The output voltage can be stepped down to as low as the 0.795-V voltage reference (Vref).

The device has a power good comparator (PWRGD) with hysteresis which monitors the output voltage through the VSENSE pin. The PWRGD pin is an open-drain MOSFET which is pulled low when the VSENSE pin voltage is less than 91% or greater than 109% of the reference voltage Vref and asserts high when the VSENSE pin voltage is 94% to 106% of the Vref.

The SS/TR (slow start/tracking) pin is used to minimize inrush currents or provide power-supply sequencing during power-up. A small-value capacitor or resistor divider should be coupled to the pin for slow start or critical power-supply sequencing requirements.

The device is protected from output overvoltage, overload, and thermal fault conditions. The device minimizes excessive output overvoltage transients by taking advantage of the overvoltage circuit power good comparator. When the overvoltage comparator is activated, the high-side MOSFET is turned off and prevented from turning on until the VSENSE pin voltage is lower than 106% of the Vref. The device implements both high-side MOSFET overload protection and bidirectional low-side MOSFET overload protections, which help control the inductor current and avoid current runaway. The device also shuts down if the junction temperature is higher than thermal shutdown trip point. The device is restarted under control of the slow-start circuit automatically when the junction temperature drops 10°C typical below the thermal shutdown trip point.

8.2 Functional Block Diagram

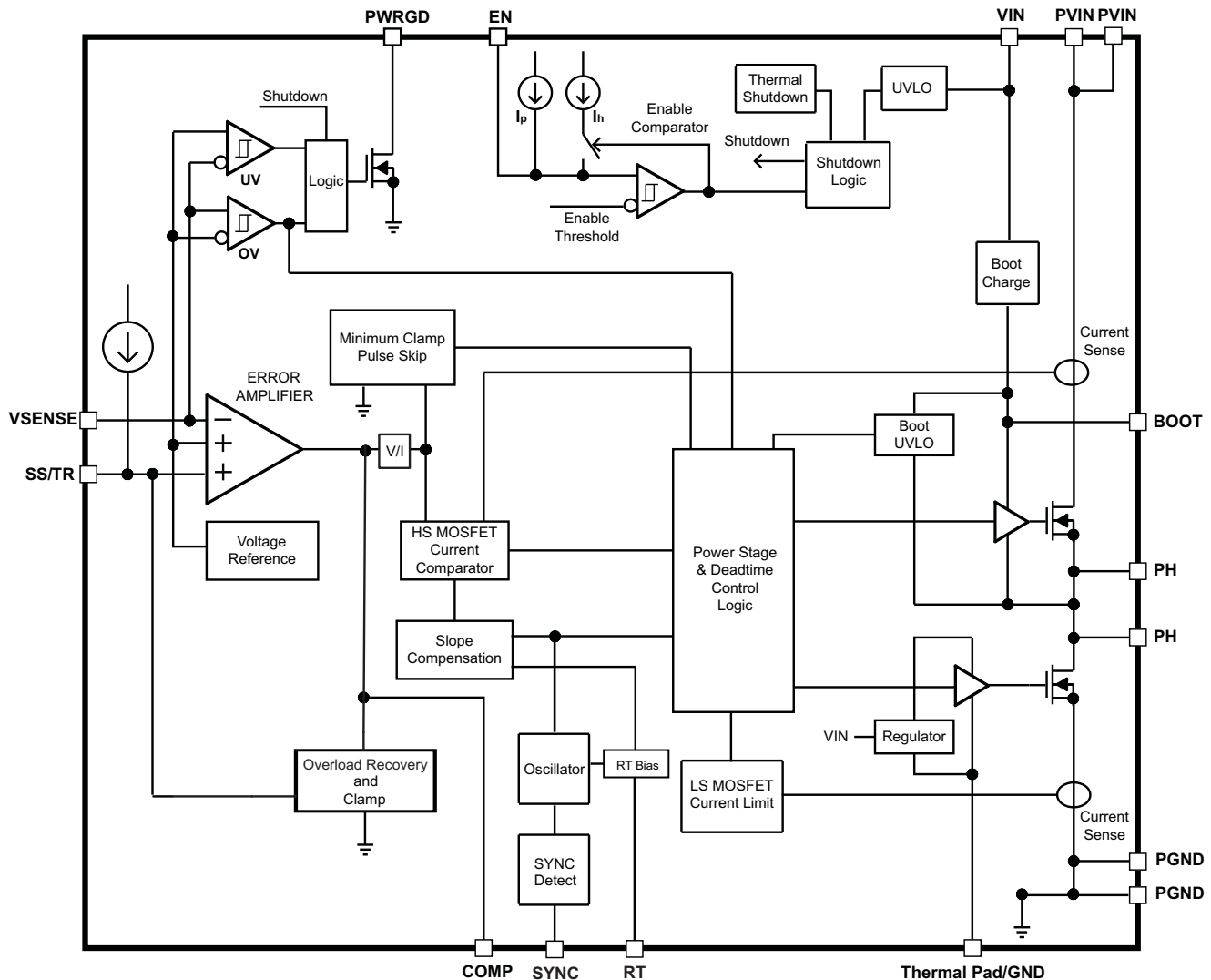

8.3 Feature Description

8.3.1 VIN and Power VIN Pins (VIN and PVIN)

The device allows for a variety of applications by using the VIN and PVIN pins together or separately. The VIN pin voltage supplies the internal control circuits of the device. The PVIN pin voltage provides the input voltage to the power converter system.

If tied together, the input voltage for VIN and PVIN can range from 3 to 6.3 V. If using the VIN separately from PVIN, the VIN pin must be between 3 and 6.3 V, and the PVIN pin can range from as low as 1.6 to 6.3 V. A voltage divider connected to the EN pin can adjust the input voltage UVLO appropriately. Adjusting the input voltage UVLO on the PVIN pin helps to provide consistent power-up behavior.

8.3.2 PVIN vs Frequency

With VIN tied to PVIN, minimum off-time determines what output voltage is achievable over frequency range.

8.3.3 Voltage Reference

The voltage reference system produces a precise voltage reference as indicated in [Electrical Characteristics: TPS50301-HT](#) and [Electrical Characteristics: TPS50601-SP](#).

Feature Description (continued)

8.3.4 Adjusting the Output Voltage

The output voltage is set with a resistor divider from the output (VOUT) to the VSENSE pin. TI recommends to use 1% tolerance or better divider resistors. Start with a 10 kΩ for R15 (top resistor) and use [Equation 1](#) to calculate R38 (bottom resistor divider). To improve efficiency at light loads, consider using larger-value resistors. If the values are too high, the regulator is more susceptible to noise and voltage errors from the VSENSE input current are noticeable.

$$R38 = \frac{V_{ref}}{V_o - V_{ref}} R15$$

where

- $V_{ref} = 0.795 \text{ V}$ (1)

The minimum output voltage and maximum output voltage can be limited by the minimum on-time of the high-side MOSFET and bootstrap voltage (BOOT-PH voltage) respectively. For more information, see [Bootstrap Voltage \(BOOT\) and Low Dropout Operation](#).

8.3.5 Maximum Duty Cycle Limit

The TPS50601-SP can operate at duty cycle per [Equation 2](#) and [Equation 3](#) as long as the boot capacitor voltage is higher than the preset BOOT-PH UVLO threshold, which is typically 2.2 V.

Duty cycle can be calculated based on [Equation 2](#).

$$D(V_{IN}) = \frac{V_{OUT} + I_{OUT_max} \cdot R_{Tesr} + I_{OUT_max} \cdot R_{ds_low}}{V_{IN} - I_{OUT_max} \cdot R_{ds_high} + I_{OUT_max} \cdot R_{ds_low}}$$

where

- $R_{Tesr} = R_{dcr} + R_{trace}$
- R_{dcr} is the dc resistance of the inductor.
- R_{trace} is the dc trace resistance (miscellaneous drop).
- R_{ds_high} is the maximum R_{DS} of the high-side MOSFET.
- R_{ds_low} is the maximum R_{DS} of the low-side MOSFET. (2)

8.3.6 PVIN vs Frequency

With V_{IN} tied to PV_{IN} , minimum off-time determines the output voltage that is achievable over frequency range. For $V_{IN} = PV_{IN}$ must be $\geq 3 \text{ V}$. For $V_{IN} = 3 \text{ V}$, PV_{IN} can vary from 1.6 to 6.3 V as highlighted in [Electrical Characteristics: TPS50301-HT](#).

This is given by [Equation 3](#).

$$PV_{in_min}(f_{SW}) = \frac{V_o + I_o(R_{ds_onLS} + R_{misc})}{1 - T_{off_min} \cdot f_{SW}}$$

where

- R_{ds_onLS} = Low-side R_{ds-on}
- R_{misc} = Miscellaneous trace drops
- T_{off_min} = Minimum off time (3)

Using this approach, the designer can calculate minimum PV_{IN} required for specific V_{OUT} as indicated in the example in [Figure 18](#).

Feature Description (continued)

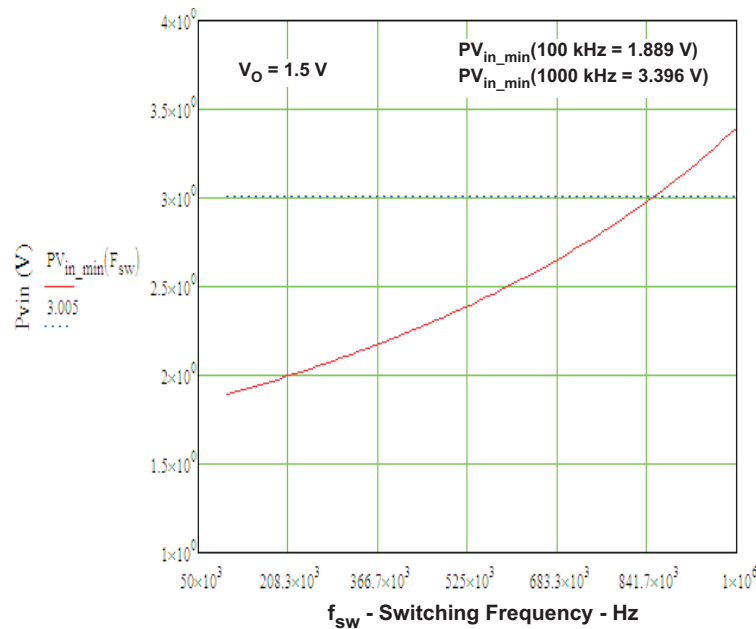

Figure 18. PV_{IN} vs Frequency

8.3.7 Safe Start-Up into Prebiased Outputs

The device is designed to prevent the low-side MOSFET from discharging a prebiased output. During monotonic prebiased startup, the low-side MOSFET is not allowed to sink current until the SS/TR pin voltage is higher than 1.4 V.

8.3.8 Error Amplifier

The device uses a transconductance error amplifier. The error amplifier compares the VSENSE pin voltage to the lower of the SS/TR pin voltage or the internal 0.795-V voltage reference. The transconductance of the error amplifier is 1300 $\mu\text{A/V}$ during normal operation. The frequency compensation network is connected between the COMP pin and ground. Error amplifier dc gain is typically 39000 V/V with minimum value of 22000 V/V per design.

8.3.9 Slope Compensation

The device adds a compensating ramp to the switch current signal. This slope compensation prevents subharmonic oscillations. The available peak inductor current remains constant over the full duty cycle range. Minimum peak-to-peak inductor current should be greater than 1 A.

8.3.10 Enable and Adjust UVLO

The EN pin provides electrical on and off control of the device. When the EN pin voltage exceeds the threshold voltage, the device starts operation. If the EN pin voltage is pulled below the threshold voltage, the regulator stops switching and enters low I_q state. If an external Schottky diode is used from V_{IN} to boot, then a bleeder may be required <1 mA to ensure output is low when the unit is disabled by EN pin.

The EN pin has an internal pullup current source, allowing the user to float the EN pin for enabling the device. If an application requires controlling the EN pin, use open-drain or open-collector output logic to interface with the pin.

The device implements internal UVLO circuitry on the VIN pin. The device is disabled when the VIN pin voltage falls below the internal VIN UVLO threshold. The internal VIN UVLO threshold has a hysteresis of 50 mV typical.

Feature Description (continued)

If an application requires either a higher UVLO threshold on the VIN pin or a secondary UVLO on the PVIN in split-rail applications, then the EN pin can be configured as shown in Figure 19, Figure 20, and Figure 21. When using the external UVLO function, TI recommends to set the hysteresis to be >500 mV.

The EN pin has a small pullup current, I_p , which sets the default state of the pin to enable when no external components are connected. The pullup current is also used to control the voltage hysteresis for the UVLO function because it increases by I_h after the EN pin crosses the enable threshold. Calculate the UVLO thresholds with Equation 4 and Equation 5.

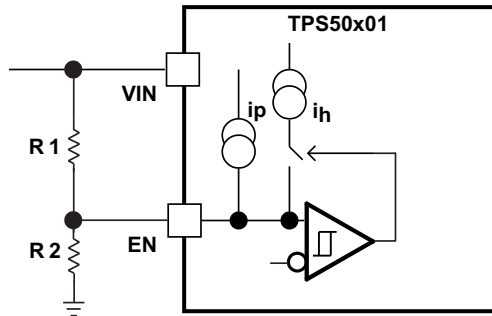

Figure 19. Adjustable VIN UVLO

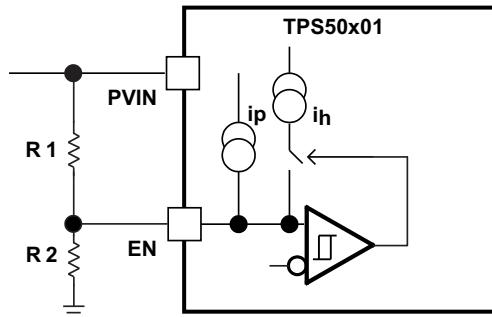

Figure 20. Adjustable PVIN UVLO, VIN ≥ 3 V

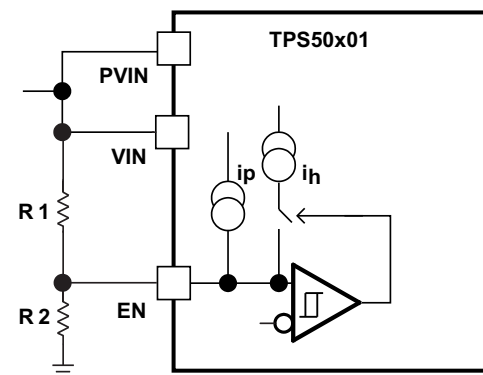

Figure 21. Adjustable VIN and PVIN UVLO

$$R1 = \frac{V_{START} \left(\frac{V_{ENFALLING}}{V_{ENRISING}} \right) - V_{STOP}}{I_p \left(1 - \frac{V_{ENFALLING}}{V_{ENRISING}} \right) + I_h}$$

(4)

Feature Description (continued)

$$R2 = \frac{R1 \times V_{ENFALLING}}{V_{STOP} - V_{ENFALLING} + R1(I_p + I_h)}$$

where

- $I_h = 3 \mu\text{A}$
- $I_p = 3.2 \mu\text{A}$
- $V_{ENRISING} = 1.131 \text{ V}$
- $V_{ENFALLING} = 1.09 \text{ V}$

(5)

8.3.11 Adjustable Switching Frequency and Synchronization (SYNC)

The switching frequency of the device supports three modes of operations. The modes of operation are set by the conditions on the RT and SYNC pins. At a high level, these modes can be described as master, internal oscillator, and external synchronization modes.

In master mode, the RT pin should be left floating; the internal oscillator is set to 500 kHz, and the SYNC pin is set as an output clock. The SYNC output is in phase with respect to the internal oscillator. SYNC out signal level is the same as V_{IN} level with 50% duty cycle. SYNC signal feeding the slave module—which is in phase with the master clock—gets internally inverted (180° out of phase with the master clock) internally in the slave module.

In internal oscillator mode, a resistor is connected between the RT pin and GND. The SYNC pin requires a 10-k Ω resistor to GND for this mode to be effective. The switching frequency of the device is adjustable from 100 kHz to 1 MHz by placing a maximum of 510 k Ω and a minimum of 47 k Ω respectively. To determine the RT resistance for a given switching frequency, use Equation 6 or the curve in Figure 22. To reduce the solution size, the designer should set switching frequency as high as possible, but consider the tradeoffs of supply efficiency and minimum controllable on-time.

$$RT(F_{sw}) = 67009 \times F_{sw}^{-1.0549}$$

where

- RT in k Ω
- F_{sw} in kHz

(6)

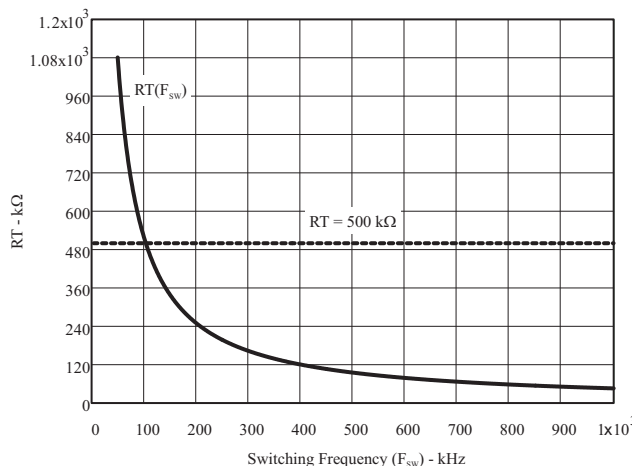

Figure 22. RT vs Switching Frequency

When operating the converter in internal oscillator mode (internal oscillator determines the switching frequency (500 kHz) default), the synchronous pin becomes the output and there is a phase inversion. When trying to parallel with another converter, the RT pin of the second (slave) converter must have its RT pin populated such that the converter frequency of the slave converter must be within $\pm 5\%$ of the master converter. This is required because the RT pin also sets the proper operation of slope compensation.

Feature Description (continued)

In external synchronization mode, a resistor is connected between the RT pin and GND. The Sync pin requires a toggling signal for this mode to be effective. The switching frequency of the device goes 1:1 with that of Sync pin. External system clock-user supplied sync clock signal determines the switching frequency. If no external clock signal is detected for 20 μ s, then TPS50601-SP transitions to its internal clock, which is typically 500 kHz. An external synchronization using an inverter to obtain phase inversion is necessary. RT values of the master and slave converter must be within $\pm 5\%$ of the external synchronization frequency. This is necessary for proper slope compensation. A resistance in the RT pin is required for proper operation of the slope compensation circuit. To determine the RT resistance for a given switching frequency, use [Equation 6](#) or the curve in [Figure 22](#). To reduce the solution size, the designer should set switching frequency as high as possible, but consider the tradeoffs of supply efficiency and minimum controllable on-time.

These modes are described in [Table 1](#).

Table 1. Switching Frequency, SYNC and RT Pin Usage Table

RT Pin	SYNC Pin	Switching Frequency	Description and Notes
Float	Generates an output signal	500 kHz	SYNC pin behaves as an output. SYNC output signal is 180° out of phase to the internal 500-kHz switching frequency.
47- to 485-k Ω resistor to AGND	10-k Ω resistor to AGND	100 kHz to 1 MHz	Internally generated switching frequency is based upon the resistor value present at the RT pin.
	User-supplied sync clock or TPS50601-SP master device sync output	Internally synchronized to external clock	Set value of RT that corresponds to the externally supplied sync frequency.

8.3.12 Slow Start (SS/TR)

The device uses the lower voltage of the internal voltage reference or the SS/TR pin voltage as the reference voltage and regulates the output accordingly. A capacitor on the SS/TR pin to ground implements a slow-start time. The device has an internal pullup current source of 5 mA that charges the external slow-start capacitor. [Equation 7](#) shows the calculations for the slow-start time (T_{SS} , 10% to 90%) and slow-start capacitor (C_{SS}). The voltage reference (V_{ref}) is 0.795 V and the slow-start charge current (I_{SS}) is 2.5 μ A.

$$t_{SS} \text{ (ms)} = \frac{C_{SS} \text{ (nF)} \times V_{ref} \text{ (V)}}{I_{SS} \text{ (\mu A)}} \quad (7)$$

When the input UVLO is triggered, the EN pin is pulled below 1.032 V, or a thermal shutdown event occurs the device stops switching and enters low current operation. At the subsequent power-up, when the shutdown condition is removed, the device does not start switching until it has discharged its SS/TR pin to ground ensuring proper soft-start behavior.

8.3.13 Power Good (PWRGD)

The PWRGD pin is an open-drain output. When the VSENSE pin is between 94% and 106% of the internal voltage reference, the PWRGD pin pull-down is deasserted and the pin floats. TI recommends to use a pullup resistor between 10 to 100 k Ω to a voltage source that is 5.5 V or less. The PWRGD is in a defined state when the VIN input voltage is greater than 1 V but has reduced current sinking capability. The PWRGD achieves full current sinking capability when the VIN input voltage is above 3 V.

The PWRGD pin is pulled low when VSENSE is lower than 91% or greater than 109% of the nominal internal reference voltage. Also, the PWRGD is pulled low, if the input UVLO or thermal shutdown are asserted, the EN pin is pulled low or the SS/TR pin is below 1.4 V.

8.3.14 Bootstrap Voltage (BOOT) and Low Dropout Operation

The device has an integrated boot regulator, and requires a small ceramic capacitor between the BOOT and PH pins to provide the gate drive voltage for the high-side MOSFET. The boot capacitor is charged when the BOOT pin voltage is less than VIN and BOOT-PH voltage is below regulation. The value of this ceramic capacitor should be 0.1 μ F. TI recommends a ceramic capacitor with an X7R- or X5R-grade dielectric with a voltage rating of 10 V or higher because of the stable characteristics over temperature and voltage.

To improve dropout, the device is designed to operate at a high duty cycle as long as the BOOT to PH pin voltage is greater than the BOOT-PH UVLO threshold, which is typically 2.1 V. When the voltage between BOOT and PH drops below the BOOT-PH UVLO threshold, the high-side MOSFET is turned off and the low-side MOSFET is turned on allowing the boot capacitor to be recharged. In applications with split-input voltage rails, high duty cycle operation can be achieved as long as $(V_{IN} - PV_{IN}) > 4 \text{ V}$.

Maximum switching frequency is also limited by minimum on-time (specified in [Electrical Characteristics: TPS50301-HT](#)) as indicated by [Equation 8](#). Switching frequency will be worst case at no load conditions.

$$F_{SW} = \frac{1}{T} = \frac{V_O + R_{ds_on} \cdot (I_O)}{V_{IN} \cdot (T_{on_max})} \quad (8)$$

8.3.15 Sequencing (SS/TR)

Many of the common power-supply sequencing methods can be implemented using the SS/TR, EN, and PWRGD pins.

The sequential method is shown in [Figure 23](#) using two TPS50601-SP devices. The power good of the first device is coupled to the EN pin of the second device, which enables the second power supply after the primary supply reaches regulation.

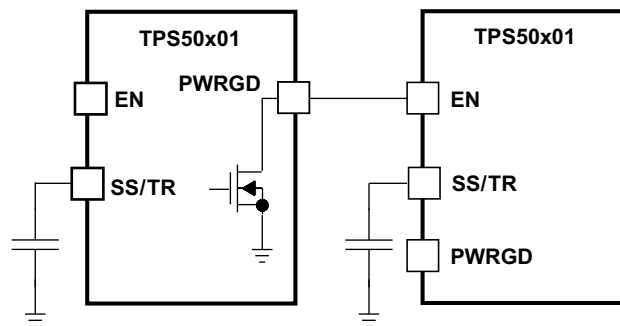

Figure 23. Sequential Start-Up Sequence

[Figure 24](#) shows the method implementing ratiometric sequencing by connecting the SS/TR pins of two devices together. The regulator outputs ramp up and reach regulation at the same time. When calculating the slow-start time, the pullup current source must be doubled in [Equation 7](#).

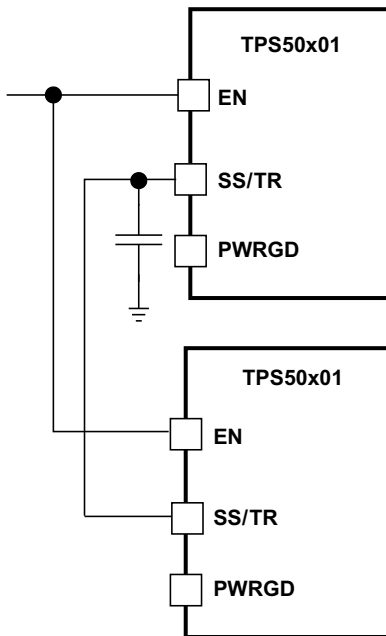

Figure 24. Ratiometric Start-Up Sequence

Ratiometric and simultaneous power-supply sequencing can be implemented by connecting the resistor network of R1 and R2 (shown in [Figure 25](#)) to the output of the power supply that needs to be tracked or another voltage reference source. Using [Equation 9](#) and [Equation 10](#), the tracking resistors can be calculated to initiate the Vout2 slightly before, after, or at the same time as Vout1. [Equation 11](#) is the voltage difference between Vout1 and Vout2.

To design a ratiometric start-up in which the Vout2 voltage is slightly greater than the Vout1 voltage when Vout2 reaches regulation, use a negative number in [Equation 9](#) and [Equation 10](#) for ΔV . [Equation 11](#) results in a positive number for applications where the Vout2 is slightly lower than Vout1 when Vout2 regulation is achieved.

The ΔV variable is 0 V for simultaneous sequencing. To minimize the effect of the inherent SS/TR to VSENSE offset ($V_{ssoffset}$, 29 mV) in the slow-start circuit and the offset created by the pullup current source (I_{ss} , 2 μA) and tracking resistors, the $V_{ssoffset}$ and I_{ss} are included as variables in the equations.

To ensure proper operation of the device, the calculated R1 value from [Equation 9](#) must be greater than the value calculated in [Equation 12](#).

$$R1 = \frac{V_{out2} + \Delta V}{V_{ref}} \times \frac{V_{ssoffset}}{I_{ss}} \quad (9)$$

$$R2 = \frac{V_{ref} \times R1}{V_{out2} + \Delta V - V_{ref}} \quad (10)$$

$$\Delta V = V_{out1} - V_{out2} \quad (11)$$

$$R1 > 2800 \times V_{out1} - 180 \times \Delta V \quad (12)$$

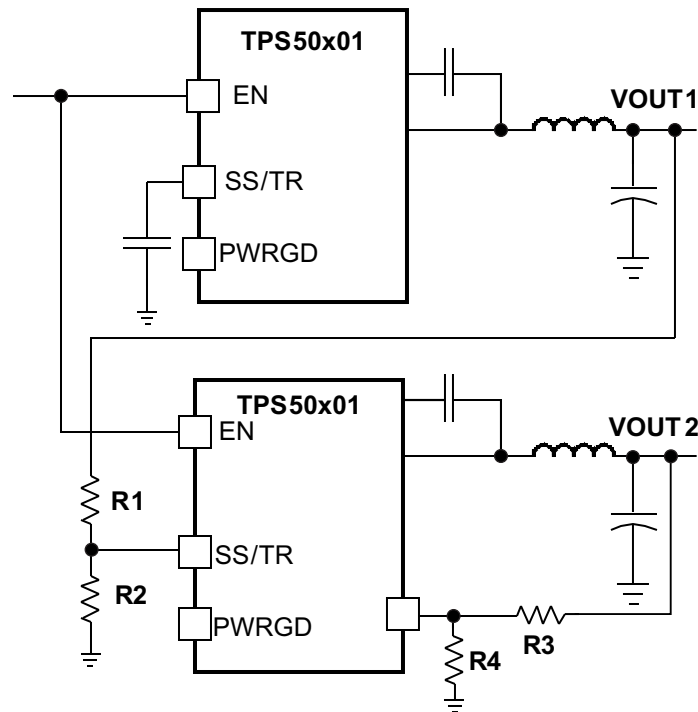

Figure 25. Ratiometric and Simultaneous Start-Up Sequence

8.3.16 Output Overvoltage Protection (OVP)

The device incorporates an output OVP circuit to minimize output voltage overshoot. For example, when the power supply output is overloaded, the error amplifier compares the actual output voltage to the internal reference voltage. If the VSENSE pin voltage is lower than the internal reference voltage for a considerable time, the output of the error amplifier demands maximum output current. After the condition is removed, the regulator output rises and the error amplifier output transitions to the steady-state voltage. In some applications with small output capacitance, the power supply output voltage can respond faster than the error amplifier. This leads to the possibility of an output overshoot. The OVP feature minimizes the overshoot by comparing the VSENSE pin voltage to the OVP threshold. If the VSENSE pin voltage is greater than the OVP threshold, the high-side MOSFET is turned off, preventing current from flowing to the output and minimizing output overshoot. When the VSENSE voltage drops lower than the OVP threshold, the high-side MOSFET is allowed to turn on at the next clock cycle.

8.3.17 Overcurrent Protection

The device is protected from overcurrent conditions by cycle-by-cycle current limiting on both the high-side and low-side MOSFET.

8.3.17.1 High-Side MOSFET Overcurrent Protection

The device implements current mode control which uses the COMP pin voltage to control the turn off of the high-side MOSFET and the turn on of the low-side MOSFET on a cycle-by-cycle basis. Each cycle the switch current and the current reference generated by the COMP pin voltage are compared, when the peak switch current intersects the current reference, the high-side switch is turned off.

8.3.17.2 Low-Side MOSFET Overcurrent Protection

While the low-side MOSFET is turned on its conduction current is monitored by the internal circuitry. During normal operation the low-side MOSFET sources current to the load. At the end of every clock cycle, the low-side MOSFET sourcing current is compared to the internally set low-side sourcing current limit. If the low-side sourcing current is exceeded, the high-side MOSFET is not turned on and the low-side MOSFET stays on for the next cycle. The high-side MOSFET is turned on again when the low-side current is below the low-side sourcing current limit at the start of a cycle.

The low-side MOSFET may also sink current from the load. If the low-side sinking current limit is exceeded, the low-side MOSFET is turned off immediately for the rest of that clock cycle. In this scenario, both MOSFETs are off until the start of the next cycle.

When the low-side MOSFET turns off, the switch node increases and forward biases the high-side MOSFET parallel diode (the high-side MOSFET is still off at this stage).

8.3.18 TPS50601-SP Thermal Shutdown

The internal thermal shutdown circuitry forces the device to stop switching if the junction temperature exceeds 175°C typically. The device reinitiates the power-up sequence when the junction temperature drops below 165°C typically.

8.3.19 Turn-On Behavior

Minimum on-time specification determines the maximum operating frequency of the design. As the unit starts up and goes through its soft-start process, the required duty-cycle is less than the minimum controllable on-time. This can cause the converter to skip pulses. Thus, instantaneous output pulses can be higher or lower than the desired voltage. This behavior is only evident when operating at high frequency with high bandwidth. When the minimum on-pulse is greater than the minimum controllable on-time, the turn-on behavior is normal. When operating at low frequencies (100 kHz or less), the turn-on behavior does not exhibit any ringing at initial startup.

8.3.20 Small Signal Model for Loop Response

Figure 26 shows an equivalent model for the device control loop, which can be modeled in a circuit simulation program to check frequency response and transient responses. The error amplifier is a transconductance amplifier with a g_m of 1300 $\mu\text{A/V}$. The error amplifier can be modeled using an ideal voltage-controlled current source. The resistor, R_{oea} (30 M Ω), and capacitor, C_{oea} (20.7 pF), model the open-loop gain and frequency response of the error amplifier. The 1-mV ac voltage source between the nodes a and b effectively breaks the control loop for the frequency response measurements. Plotting a/c and c/b show the small signal responses of the power stage and frequency compensation respectively. Plotting a/b shows the small signal response of the overall loop. The dynamic loop response can be checked by replacing the R_L with a current source with the appropriate load-step amplitude and step rate in a time domain analysis.

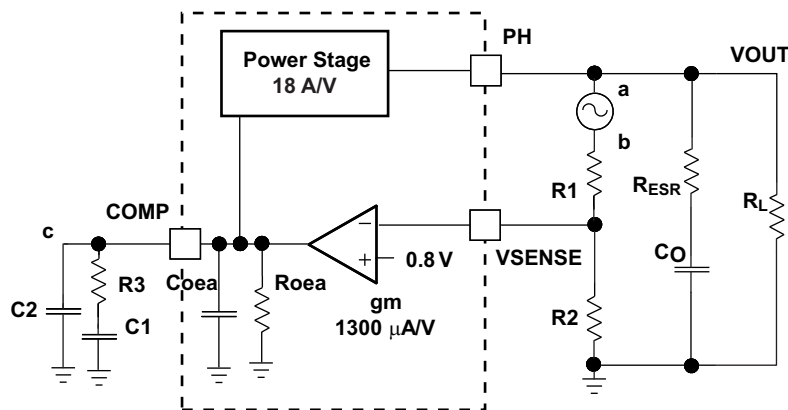

Figure 26. Small Signal Model For Loop Response

8.3.21 Simple Small Signal Model for Peak Current Mode Control

Figure 27 is a simple small signal model that can be used to understand how to design the frequency compensation. The device power stage can be approximated to a voltage-controlled current source (duty cycle modulator) supplying current to the output capacitor and load resistor. Equation 13 shows the control to output transfer function, which consists of a dc gain, one dominant pole, and one ESR zero. The quotient of the change in switch current and the change in COMP pin voltage (node c in Figure 26) is the power stage transconductance ($g_{m_{ps}}$), which is 18 A/V for the device. The dc gain of the power stage is the product of $g_{m_{ps}}$ and the load

resistance (R_L) as shown in Equation 14 with resistive loads. As the load current increases, the dc gain decreases. This variation with load may seem problematic at first glance, but fortunately, the dominant pole moves with load current (see Equation 15). The combined effect is highlighted by the dashed line in Figure 28. As the load current decreases, the gain increases and the pole frequency lowers, keeping the 0-dB crossover frequency the same for the varying load conditions, which makes it easier to design the frequency compensation.

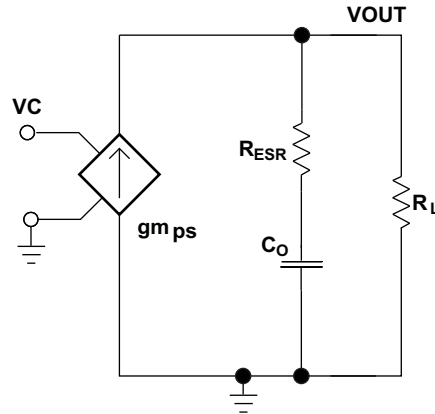

Figure 27. Simplified Small Signal Model for Peak Current Mode Control

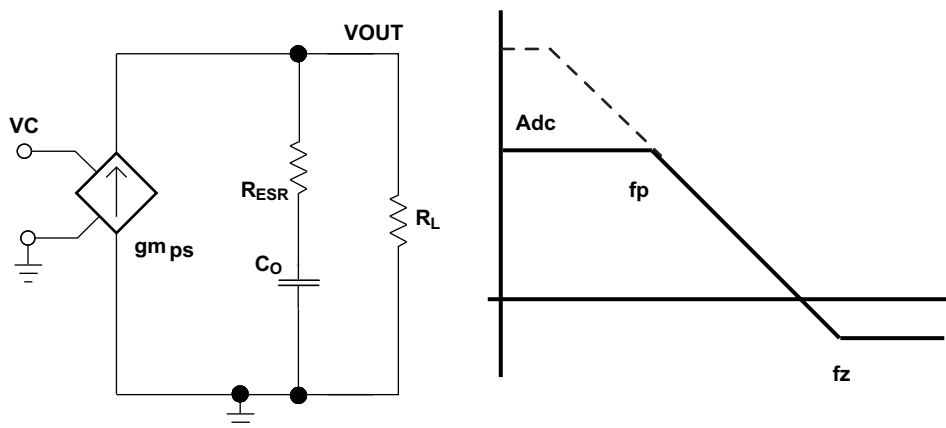

Figure 28. Simplified Frequency Response for Peak Current Mode Control

$$\frac{V_{OUT}}{VC} = A_{dc} \times \frac{\left(1 + \frac{s}{2\pi \times fz}\right)}{\left(1 + \frac{s}{2\pi \times fp}\right)} \tag{13}$$

$$A_{dc} = g_{m_{ps}} \times R_L \tag{14}$$

$$fp = \frac{1}{C_O \times R_L \times 2\pi} \tag{15}$$

$$fz = \frac{1}{C_O \times R_{ESR} \times 2\pi}$$

where

- $g_{m_{ea}}$ is the GM amplifier gain (1300 $\mu A/V$).
- $g_{m_{ps}}$ is the power stage gain (18 A/V).
- R_L is the load resistance.
- C_O is the output capacitance.

- R_{ESR} is the equivalent series resistance of the output capacitor. (16)

8.3.22 Small Signal Model for Frequency Compensation

The device uses a transconductance amplifier for the error amplifier and readily supports two of the commonly used frequency compensation circuits shown in Figure 29. In Type 2A, one additional high-frequency pole is added to attenuate high-frequency noise.

The following design guidelines are provided for advanced users who prefer to compensate using the general method. The step-by-step design procedure described in *Detailed Design Procedure* may also be used.

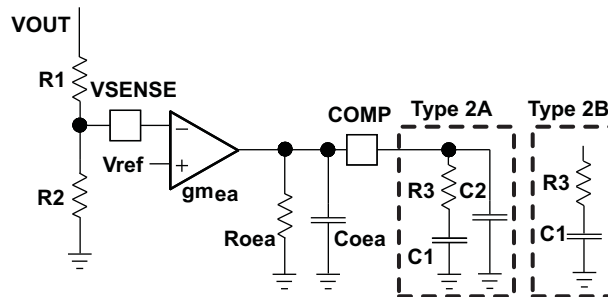

Figure 29. Types of Frequency Compensation

The general design guidelines for device loop compensation are as follows:

1. Determine the crossover frequency f_c . A good starting point is one-tenth of the switching frequency, f_{SW} .
2. R_3 can be determined by:

$$R_3 = \frac{2\pi \times f_c \times V_{OUT} \times C_o}{g_{m_{ea}} \times V_{ref} \times g_{m_{ps}}}$$

where

- $g_{m_{ea}}$ is the GM amplifier gain (1300 $\mu A/V$).
 - $g_{m_{ps}}$ is the power stage gain (18 A/V).
 - V_{ref} is the reference voltage (0.795 V).
- (17)

3. Place a compensation zero at the dominant pole $\left(f_p = \frac{1}{C_o \times R_L \times 2\pi} \right)$.

C_1 can be determined by

$$C_1 = \frac{R_L \times C_o}{R_3}$$

(18)

4. C_2 is optional. It can be used to cancel the zero from the equivalent series resistance (ESR) of the output capacitor C_o .

$$C_2 = \frac{R_{ESR} \times C_o}{R_3}$$

(19)

8.4 Device Functional Modes

8.4.1 Fixed-Frequency PWM Control

The device uses fixed frequency, peak current mode control. The output voltage is compared through external resistors on the VSENSE pin to an internal voltage reference by an error amplifier which drives the COMP pin. An internal oscillator initiates the turn on of the high-side power switch. The error amplifier output is converted into a current reference which compares to the high-side power switch current. When the power switch current reaches the current reference generated by the COMP voltage level, the high-side power switch is turned off and the low-side power switch is turned on.

Device Functional Modes (continued)

8.4.2 Continuous Current Mode (CCM) Operation

As a synchronous buck converter, the device normally works in CCM under all load conditions.

9 Application and Implementation

NOTE

Information in the following applications sections is not part of the TI component specification, and TI does not warrant its accuracy or completeness. TI's customers are responsible for determining suitability of components for their purposes. Customers should validate and test their design implementation to confirm system functionality.

9.1 Application Information

The TPS50x01 device is a highly-integrated synchronous step-down DC-DC converter. The device is used to convert a higher DC-DC input voltage to a lower DC output voltage with a maximum output current of 6 A.

The TPS50601-SP user's guide is available on the TI website, [SLVU499](#). The guide highlights standard EVM test results, schematic, and BOM for reference. (Basic design equations in following sections are provided for reference only)

9.2 Typical Application

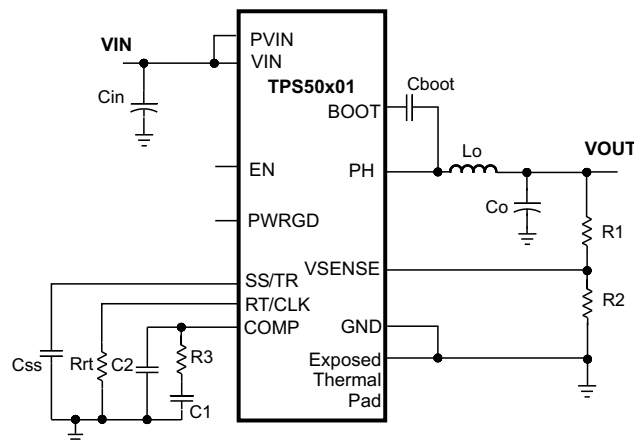

Figure 30. Typical Application Schematic

9.2.1 Design Requirements

This example details the design of a high frequency switching regulator design using ceramic output capacitors. A few parameters must be known in order to start the design process. These parameters are typically determined at the system level. For this example, we start with the following known parameters:

Table 2. Design Parameters

DESIGN PARAMETER	EXAMPLE VALUE
Output voltage	3.3 V
Output current	6 A
Transient response 1-A load step	$\Delta V_{out} = 5\%$
Input voltage	5 V nominal, 4.5 to 6.3 V
Output voltage ripple	33 mV p-p
Start input voltage (rising Vin)	4.425V
Stop input voltage (falling Vin)	4.234V
Switching frequency	480 kHz

9.2.2 Detailed Design Procedure

9.2.2.1 Operating Frequency

The first step is to decide on a switching frequency for the regulator. There is a trade off between higher and lower switching frequencies. Higher switching frequencies may produce smaller a solution size using lower valued inductors and smaller output capacitors compared to a power supply that switches at a lower frequency. However, the higher switching frequency causes extra switching losses, which hurt the converter's efficiency and thermal performance. In this design, a moderate switching frequency of 480 kHz is selected to achieve both a small solution size and a high efficiency operation.

9.2.2.2 Output Inductor Selection

To calculate the value of the output inductor, use [Equation 20](#). KIND is a coefficient that represents the amount of inductor ripple current relative to the maximum output current. The inductor ripple current is filtered by the output capacitor. Therefore, choosing high inductor ripple currents impact the selection of the output capacitor since the output capacitor must have a ripple current rating equal to or greater than the inductor ripple current. In general, the inductor ripple value is at the discretion of the designer; however, KIND is normally from 0.1 to 0.4 for the majority of applications.

$$L1 = \frac{V_{inmax} - V_{out}}{I_o \cdot Kind} \cdot \frac{V_{out}}{V_{inmax} \cdot f_{sw}} \quad (20)$$

For this design example, use KIND = 0.1 and the inductor value is calculated to be 2.78 μ H. For this design, a nearest standard value was chosen: 3.3 μ H. For the output filter inductor, it is important that the RMS current and saturation current ratings not be exceeded. The RMS and peak inductor current can be found from [Equation 22](#) and [Equation 23](#).

$$I_{ripple} = \frac{V_{inmax} - V_{out}}{L1} \cdot \frac{V_{out}}{V_{inmax} \cdot f_{sw}} \quad (21)$$

$$I_{Lrms} = \sqrt{I_o^2 + \frac{1}{12} \cdot \left(\frac{V_o \cdot (V_{inmax} - V_o)}{V_{inmax} \cdot L1 \cdot f_{sw}} \right)^2} \quad (22)$$

$$I_{Lpeak} = I_{out} + \frac{I_{ripple}}{2} \quad (23)$$

For this design, the RMS inductor current is 6.02 A and the peak inductor current is 6.84 A. The chosen inductor is a Coilcraft MSS1048 series 3.3 μ H. It has a saturation current rating of 7.38 A and a RMS current rating of 7.22 A.

The current flowing through the inductor is the inductor ripple current plus the output current. During power up, faults or transient load conditions, the inductor current can increase above the calculated peak inductor current level calculated above. In transient conditions, the inductor current can increase up to the switch current limit of the device. For this reason, the most conservative approach is to specify an inductor with a saturation current rating equal to or greater than the switch current limit rather than the peak inductor current.

9.2.2.3 Output Capacitor Selection

There are three primary considerations for selecting the value of the output capacitor. The output capacitor determines the modulator pole, the output voltage ripple, and how the regulator responds to a large change in load current. The output capacitance needs to be selected based on the more stringent of these three criteria

The desired response to a large change in the load current is the first criteria. The output capacitor needs to supply the load with current when the regulator can not. This situation would occur if there are desired hold-up times for the regulator where the output capacitor must hold the output voltage above a certain level for a specified amount of time after the input power is removed. The regulator is also temporarily not able to supply sufficient output current if there is a large, fast increase in the current needs of the load such as a transition from no load to full load. The regulator usually needs two or more clock cycles for the control loop to see the change

in load current and output voltage and adjust the duty cycle to react to the change. The output capacitor must be sized to supply the extra current to the load until the control loop responds to the load change. The output capacitance must be large enough to supply the difference in current for 2 clock cycles while only allowing a tolerable amount of droop in the output voltage. Equation 24 shows the minimum output capacitance necessary to accomplish this.

$$C_o > \frac{2 \cdot \Delta I_{out}}{f_{sw} \cdot \Delta V_{out}} \quad (24)$$

Where ΔI_{out} is the change in output current, f_{sw} is the regulators switching frequency and ΔV_{out} is the allowable change in the output voltage. For this example, the transient load response is specified as a 5% change in V_{out} for a load step of 1A. For this example, $\Delta I_{out} = 1.0$ A and $\Delta V_{out} = 0.05 \times 3.3 = 0.165$ V. Using these numbers gives a minimum capacitance of 25 μ F. This value does not take the ESR of the output capacitor into account in the output voltage change. For ceramic capacitors, the ESR is usually small enough to ignore in this calculation.

Equation 25 calculates the minimum output capacitance needed to meet the output voltage ripple specification. Where f_{sw} is the switching frequency, V_{ripple} is the maximum allowable output voltage ripple, and I_{ripple} is the inductor ripple current. In this case, the maximum output voltage ripple is 33mV. Under this requirement, Equation 25 yields 13.2 μ F.

$$C_o > \frac{1}{8 \cdot f_{sw}} \cdot \frac{1}{\frac{V_{ripple}}{I_{ripple}}} \quad (25)$$

Equation 26 calculates the maximum ESR an output capacitor can have to meet the output voltage ripple specification. Equation 26 indicates the ESR should be less than 19.7 m Ω . In this case, the ceramic caps' ESR is much smaller than 19.7 m Ω .

$$R_{esr} < \frac{V_{ripple}}{I_{ripple}} \quad (26)$$

Additional capacitance de-ratings for aging, temperature and DC bias should be factored in which increases this minimum value. For this example, a 47 μ F 6.3V X5R ceramic capacitor with 3 m Ω of ESR is to be used. Capacitors generally have limits to the amount of ripple current they can handle without failing or producing excess heat. An output capacitor that can support the inductor ripple current must be specified. Some capacitor data sheets specify the RMS (Root Mean Square) value of the maximum ripple current. Equation 27 can be used to calculate the RMS ripple current the output capacitor needs to support. For this application, Equation 27 yields 485mA.

$$I_{corms} = \frac{V_{out} \cdot (V_{inmax} - V_{out})}{\sqrt{12} \cdot V_{inmax} \cdot L \cdot f_{sw}} \quad (27)$$

9.2.2.4 Input Capacitor Selection

The TP50x01 requires a high quality ceramic, type X5R or X7R, input decoupling capacitor of at least 4.7 μ F of effective capacitance on the PVIN input voltage pins and 4.7 μ F on the V_{in} input voltage pin. In some applications additional bulk capacitance may also be required for the PVIN input. The effective capacitance includes any DC bias effects. The voltage rating of the input capacitor must be greater than the maximum input voltage. The capacitor must also have a ripple current rating greater than the maximum input current ripple of the TPS50x01. The input ripple current can be calculated using Equation 28.

$$I_{cirms} = I_{out} \cdot \sqrt{\frac{V_{out}}{V_{inmin}} \cdot \frac{(V_{inmin} - V_{out})}{V_{inmin}}} \quad (28)$$

The value of a ceramic capacitor varies significantly over temperature and the amount of DC bias applied to the capacitor. The capacitance variations due to temperature can be minimized by selecting a dielectric material that is stable over temperature. X5R and X7R ceramic dielectrics are usually selected for power regulator capacitors because they have a high capacitance to volume ratio and are fairly stable over temperature. The output capacitor must also be selected with the DC bias taken into account. The capacitance value of a capacitor decreases as the DC bias across a capacitor increases. For this example design, a ceramic capacitor with at least a 25-V voltage rating is required to support the maximum input voltage. For this example, one 10 μ F and

one 4.7- μ F 25-V capacitors in parallel have been selected as the VIN and PVIN inputs are tied together so the TPS50x01 may operate from a single supply. The input capacitance value determines the input ripple voltage of the regulator. The input voltage ripple can be calculated using Equation 29. Using the design example values, $I_{outmax} = 6$ A, $C_{in} = 14.7$ μ F, $F_{sw} = 480$ kHz, yields an input voltage ripple of 213 mV and a RMS input ripple current of 2.95 A.

$$\Delta V_{in} = \frac{I_{outmax} \cdot 0.25}{C_{in} \cdot f_{sw}} \quad (29)$$

9.2.2.5 Slow Start Capacitor Selection

The slow start capacitor determines the minimum amount of time it takes for the output voltage to reach its nominal programmed value during power up. This is useful if a load requires a controlled voltage slew rate. This is also used if the output capacitance is very large and would require large amounts of current to quickly charge the capacitor to the output voltage level. The large currents necessary to charge the capacitor may make the TPS50x01 reach the current limit or excessive current draw from the input power supply may cause the input voltage rail to sag. Limiting the output voltage slew rate solves both of these problems. The soft start capacitor value can be calculated using Equation 30. For the example circuit, the soft start time is not too critical since the output capacitor value is 47 μ F which does not require much current to charge to 3.3 V. The example circuit has the soft start time set to an arbitrary value of 3.5 ms which requires a 10-nF capacitor. In TPS50x01, I_{ss} is 2.5 μ A typical, and V_{ref} is 0.795 V.

$$C5(nF) = \frac{T_{ss}(ms) \times I_{ss}(\mu A)}{V_{ref}(V)} \quad (30)$$

9.2.2.6 Bootstrap Capacitor Selection

A 0.1- μ F ceramic capacitor must be connected between the BOOT to PH pin for proper operation. TI recommends to use a ceramic capacitor with X5R or better grade dielectric. The capacitor should have a voltage rating of 10 V or higher.

9.2.2.7 Undervoltage Lockout (UVLO) Set Point

The UVLO can be adjusted using the external voltage divider network of R6a and R7a. R6a is connected between VIN and the EN pin of the TPS50x01 and R7a is connected between EN and GND. The UVLO has two thresholds, one for power up when the input voltage is rising and one for power down or brown outs when the input voltage is falling. For the example design, the supply should turn on and start switching once the input voltage increases above selected voltage (UVLO start or enable). After the regulator starts switching, it should continue to do so until the input voltage falls below (UVLO stop or disable) voltage. Equation 4 and Equation 5 can be used to calculate the values for the upper and lower resistor values. For the stop voltages specified the nearest standard resistor value for R6a is 10.0 k Ω and for R7a is 3.4 k Ω .

9.2.2.8 Output Voltage Feedback Resistor Selection

The resistor divider network R5 and R6 is used to set the output voltage. For the example design, 10 k Ω was selected for R6. Using Equation 31, R5 is calculated as 31.25 k Ω . The nearest standard 1% resistor is 31.6 k Ω .

$$R5 = \frac{V_{ref}}{V_o - V_{ref}} \times R6 \quad (31)$$

9.2.2.8.1 Minimum Output Voltage

Due to the internal design of the TPS50x01, there is a minimum output voltage limit for any given input voltage. The output voltage can never be lower than the internal voltage reference of 0.8 V. Above 0.8 V, the output voltage may be limited by the minimum controllable on time. The minimum output voltage in this case is given by Equation 32

$$V_{OUTmin} = O_{ntimemin} \times f_{smax} (V_{INmax} + I_{OUTmin} (R_{DS2min} - R_{DS1min})) - I_{OUTmin} (R_L + R_{DS2min})$$

where

- V_{OUTmin} = Minimum achievable output voltage
- $O_{ntimemin}$ = Minimum controllable on-time (175 ns maximum)

- f_{smax} = Maximum switching frequency including tolerance
 - V_{INmax} = Maximum input voltage
 - I_{OUTmin} = Minimum load current
 - R_{DS1min} = Minimum high-side MOSFET on-resistance (36-32 mΩ typical)
 - R_{DS2min} = Minimum low-side MOSFET on-resistance (19 mΩ typical)
 - R_L = Series resistance of output inductor
- (32)

9.2.2.9 Compensation Component Selection

There are several industry techniques used to compensate DC/DC regulators. The method presented here is easy to calculate and yields high phase margins. For most conditions, the regulator has a phase margin between 60 and 90 degrees. The method presented here ignores the effects of the slope compensation that is internal to the TPS50x01. Since the slope compensation is ignored, the actual cross over frequency is usually lower than the cross over frequency used in the calculations. Use WEBENCH, Pspice model for simulation.

First, the modulator pole, f_{pmod} , and the esr zero, f_{zmod} must be calculated using Equation 33 and Equation 34. For C_{out} , use a derated value of 22.4 μF. Use Equation 35 and Equation 36 to estimate a starting point for the closed loop crossover frequency f_{co} . Then the required compensation components may be derived. For this design example, f_{pmod} is 12.9 kHz and f_{zmod} is 2730 kHz. Equation 35 is the geometric mean of the modulator pole and the esr zero and Equation 36 is the geometric mean of the modulator pole and one half the switching frequency. Use a frequency near the lower of these two values as the intended crossover frequency f_{co} . In this case Equation 35 yields 175 kHz and Equation 36 yields 55.7 kHz. The lower value is 55.7 kHz. A slightly higher frequency of 60.5 kHz is chosen as the intended crossover frequency.

$$f_{pmod} = \frac{I_{out}}{2 \cdot \pi \cdot V_{out} \cdot C_{out}} \quad (33)$$

$$f_{zmod} = \frac{1}{2 \cdot \pi \cdot RESR \cdot C_{out}} \quad (34)$$

$$f_{co} = \sqrt{f_{pmod} \cdot f_{zmod}} \quad (35)$$

$$f_{co} = \sqrt{f_{pmod} \cdot \frac{f_{sw}}{2}} \quad (36)$$

Now the compensation components can be calculated. First calculate the value for R2 which sets the gain of the compensated network at the crossover frequency. Use Equation 37 to determine the value of R2.

$$R2 = \frac{2\pi \cdot f_c \cdot V_{out} \cdot C_{out}}{g_{m_{ea}} \cdot V_{ref} \cdot g_{m_{ps}}} \quad (37)$$

Next calculate the value of C3. Together with R2, C3 places a compensation zero at the modulator pole frequency. Equation 38 to determine the value of C3.

$$C3 = \frac{V_{out} \cdot C_{out}}{I_{out} \cdot R2} \quad (38)$$

Using Equation 37 and Equation 38 the standard values for R2 and C3 are 1.69 kΩ and 8200 pF.

An additional high frequency pole can be used if necessary by adding a capacitor in parallel with the series combination of R2 and C3. The pole frequency is given by Equation 39. This pole is not used in this design.

$$f_p = \frac{1}{2 \cdot \pi \cdot R2 \cdot C_p} \quad (39)$$

9.2.3 Application Curve

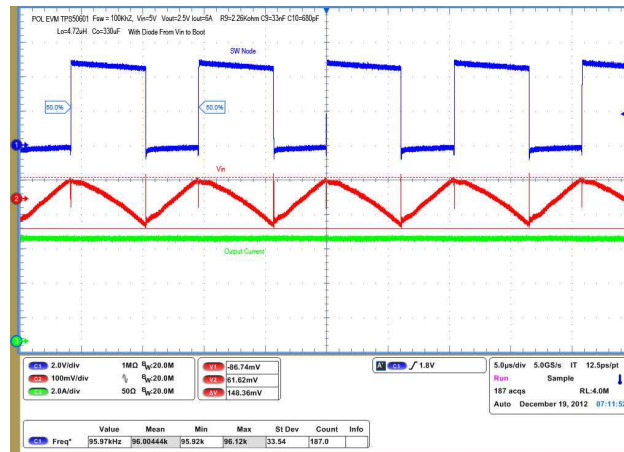

A. Per EVM - for additional details see the User's Guide, [SLVU499](#)

Figure 31. Typical Switching Waveform for 100-kHz Switching Operation

10 Power Supply Recommendations

The TPS50x01 is designed to operate from an input voltage supply range between 3.0V and 6.3V. This supply voltage must be well regulated. Power supplies must be well bypassed for proper electrical performance. This includes a minimum of one 4.7 μ F (after de-rating) ceramic capacitor, type X5R or better from PVIN to GND, and from VIN to GND. Additional local ceramic bypass capacitance may be required in systems with small input ripple specifications, in addition to bulk capacitance if the TPS50x01 device is located more than a few inches away from its input power supply. In systems with an auxiliary power rail available, the power stage input, PVIN, and the analog power input, VIN, may operate from separate input supplies. See [Layout Example](#) (layout recommendation) for recommended bypass capacitor placement.

11 Layout

11.1 Layout Guidelines

- Layout is a critical portion of good power supply design. See [Layout Example](#) for a PCB layout example.
- The top layer contains the main power traces for VIN, VOUT, and VPHASE. Also on the top layer are connections for the remaining pins of the TPS50x01 and a large top side area filled with ground.
- The top layer ground area should be connected to the internal ground layer(s) using vias at the input bypass capacitor, the output filter capacitor and directly under the TPS50x01 device to provide a thermal path from the exposed thermal pad land to ground
- The GND pin should be tied directly to the power pad under the IC and the power pad.
- For operation at full rated load, the top side ground area together with the internal ground plane, must provide adequate heat dissipating area.
- There are several signals paths that conduct fast changing currents or voltages that can interact with stray inductance or parasitic capacitance to generate noise or degrade the power supplies performance.
- To help eliminate these problems, the PVIN pin should be bypassed to ground with a low ESR ceramic bypass capacitor with X5R or X7R dielectric.
- Care should be taken to minimize the loop area formed by the bypass capacitor connections, the PVIN pins, and the ground connections.
- The VIN pin must also be bypassed to ground using a low ESR ceramic capacitor with X5R or X7R dielectric.
- Make sure to connect this capacitor to the quiet analog ground trace rather than the power ground trace of the PVIn bypass capacitor.
- Since the PH connection is the switching node, the output inductor should be located close to the PH pins, and the area of the PCB conductor minimized to prevent excessive capacitive coupling.
- The output filter capacitor ground should use the same power ground trace as the PVIN input bypass capacitor.
- Try to minimize this conductor length while maintaining adequate width.
- The small signal components should be grounded to the analog ground path as shown.
- The RT pin is sensitive to noise so the RT resistor should be located as close as possible to the IC and routed with minimal lengths of trace.
- It may be possible to obtain acceptable performance with alternate PCB layouts, however this layout has been shown to produce good results and is meant as a guideline.
- Land pattern and stencil information is provided in the data sheet addendum.

11.2 Layout Example

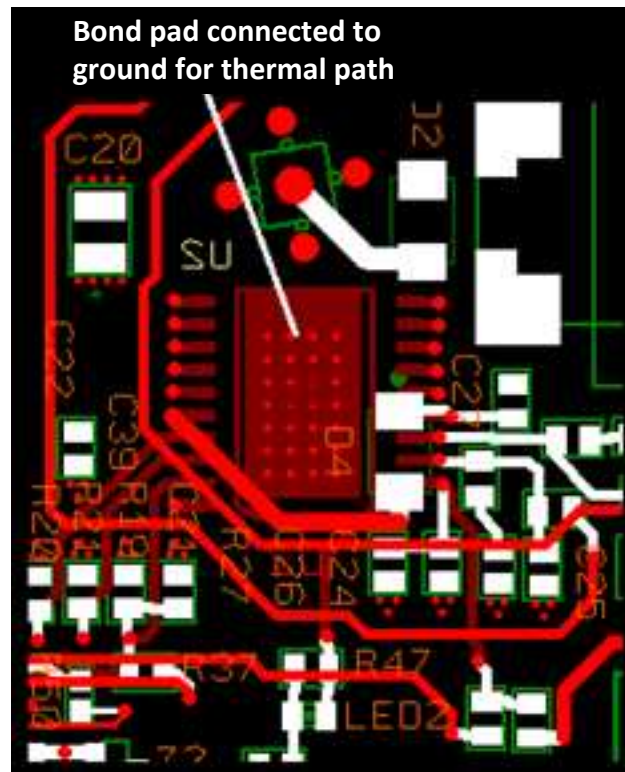

Figure 32. PCB Layout Example

12 Device and Documentation Support

12.1 Documentation Support

12.1.1 Related Documentation

For related documentation see the following:

TPS50601SP EVM, 6-A/12-A, SWIFT™ Regulator Evaluation Module, [SLVU499](#)

12.2 Related Links

The table below lists quick access links. Categories include technical documents, support and community resources, tools and software, and quick access to sample or buy.

Table 3. Related Links

PARTS	PRODUCT FOLDER	SAMPLE & BUY	TECHNICAL DOCUMENTS	TOOLS & SOFTWARE	SUPPORT & COMMUNITY
TPS50301-HT	Click here	Click here	Click here	Click here	Click here
TPS50601-SP	Click here	Click here	Click here	Click here	Click here

12.3 Community Resources

The following links connect to TI community resources. Linked contents are provided "AS IS" by the respective contributors. They do not constitute TI specifications and do not necessarily reflect TI's views; see TI's [Terms of Use](#).

TI E2E™ Online Community *TI's Engineer-to-Engineer (E2E) Community*. Created to foster collaboration among engineers. At e2e.ti.com, you can ask questions, share knowledge, explore ideas and help solve problems with fellow engineers.

Design Support *TI's Design Support* Quickly find helpful E2E forums along with design support tools and contact information for technical support.

12.4 Trademarks

SWIFT, E2E are trademarks of Texas Instruments.
All other trademarks are the property of their respective owners.

12.5 Electrostatic Discharge Caution



These devices have limited built-in ESD protection. The leads should be shorted together or the device placed in conductive foam during storage or handling to prevent electrostatic damage to the MOS gates.

12.6 Glossary

[SLYZ022](#) — *TI Glossary*.

This glossary lists and explains terms, acronyms, and definitions.

13 Mechanical, Packaging, and Orderable Information

The following pages include mechanical, packaging, and orderable information. This information is the most current data available for the designated devices. This data is subject to change without notice and revision of this document. For browser-based versions of this data sheet, refer to the left-hand navigation.

PACKAGING INFORMATION

Orderable Device	Status (1)	Package Type	Package Drawing	Pins	Package Qty	Eco Plan (2)	Lead/Ball Finish (6)	MSL Peak Temp (3)	Op Temp (°C)	Device Marking (4/5)	Samples
5962-1022101VSC	ACTIVE	CFP	HKH	20	1	TBD	AU	N / A for Pkg Type	-55 to 125	5962-1022101VS C TPS50601MHKHV	Samples
5962R1022101V9A	PREVIEW	XCEPT	KGD	0	25	TBD	Call TI	N / A for Pkg Type	-55 to 125		
5962R1022101VSC	ACTIVE	CFP	HKH	20	1	TBD	AU	N / A for Pkg Type	-55 to 125	5962R1022101VS C TPS50601-RHA	Samples
TPS50301SHKH	ACTIVE	CFP	HKH	20	1	TBD	AU	N / A for Pkg Type	-55 to 210	TPS50301SHKH	Samples
TPS50601HKH/EM	ACTIVE	CFP	HKH	20		TBD	AU	N / A for Pkg Type	25 Only	TPS50601HKH/EM EVAL ONLY	Samples
TPS50601MHKHV	ACTIVE	CFP	HKH	20	1	TBD	AU	N / A for Pkg Type	-55 to 125	5962-1022101VS C TPS50601MHKHV	Samples

(1) The marketing status values are defined as follows:

ACTIVE: Product device recommended for new designs.

LIFEBUY: TI has announced that the device will be discontinued, and a lifetime-buy period is in effect.

NRND: Not recommended for new designs. Device is in production to support existing customers, but TI does not recommend using this part in a new design.

PREVIEW: Device has been announced but is not in production. Samples may or may not be available.

OBSELETE: TI has discontinued the production of the device.

(2) Eco Plan - The planned eco-friendly classification: Pb-Free (RoHS), Pb-Free (RoHS Exempt), or Green (RoHS & no Sb/Br) - please check <http://www.ti.com/productcontent> for the latest availability information and additional product content details.

TBD: The Pb-Free/Green conversion plan has not been defined.

Pb-Free (RoHS): TI's terms "Lead-Free" or "Pb-Free" mean semiconductor products that are compatible with the current RoHS requirements for all 6 substances, including the requirement that lead not exceed 0.1% by weight in homogeneous materials. Where designed to be soldered at high temperatures, TI Pb-Free products are suitable for use in specified lead-free processes.

Pb-Free (RoHS Exempt): This component has a RoHS exemption for either 1) lead-based flip-chip solder bumps used between the die and package, or 2) lead-based die adhesive used between the die and leadframe. The component is otherwise considered Pb-Free (RoHS compatible) as defined above.

Green (RoHS & no Sb/Br): TI defines "Green" to mean Pb-Free (RoHS compatible), and free of Bromine (Br) and Antimony (Sb) based flame retardants (Br or Sb do not exceed 0.1% by weight in homogeneous material)

(3) MSL, Peak Temp. - The Moisture Sensitivity Level rating according to the JEDEC industry standard classifications, and peak solder temperature.

(4) There may be additional marking, which relates to the logo, the lot trace code information, or the environmental category on the device.

⁽⁵⁾ Multiple Device Markings will be inside parentheses. Only one Device Marking contained in parentheses and separated by a "-" will appear on a device. If a line is indented then it is a continuation of the previous line and the two combined represent the entire Device Marking for that device.

⁽⁶⁾ Lead/Ball Finish - Orderable Devices may have multiple material finish options. Finish options are separated by a vertical ruled line. Lead/Ball Finish values may wrap to two lines if the finish value exceeds the maximum column width.

Important Information and Disclaimer:The information provided on this page represents TI's knowledge and belief as of the date that it is provided. TI bases its knowledge and belief on information provided by third parties, and makes no representation or warranty as to the accuracy of such information. Efforts are underway to better integrate information from third parties. TI has taken and continues to take reasonable steps to provide representative and accurate information but may not have conducted destructive testing or chemical analysis on incoming materials and chemicals. TI and TI suppliers consider certain information to be proprietary, and thus CAS numbers and other limited information may not be available for release.

In no event shall TI's liability arising out of such information exceed the total purchase price of the TI part(s) at issue in this document sold by TI to Customer on an annual basis.

HKH (R-CDFP-F20)

CERAMIC DUAL FLATPACK

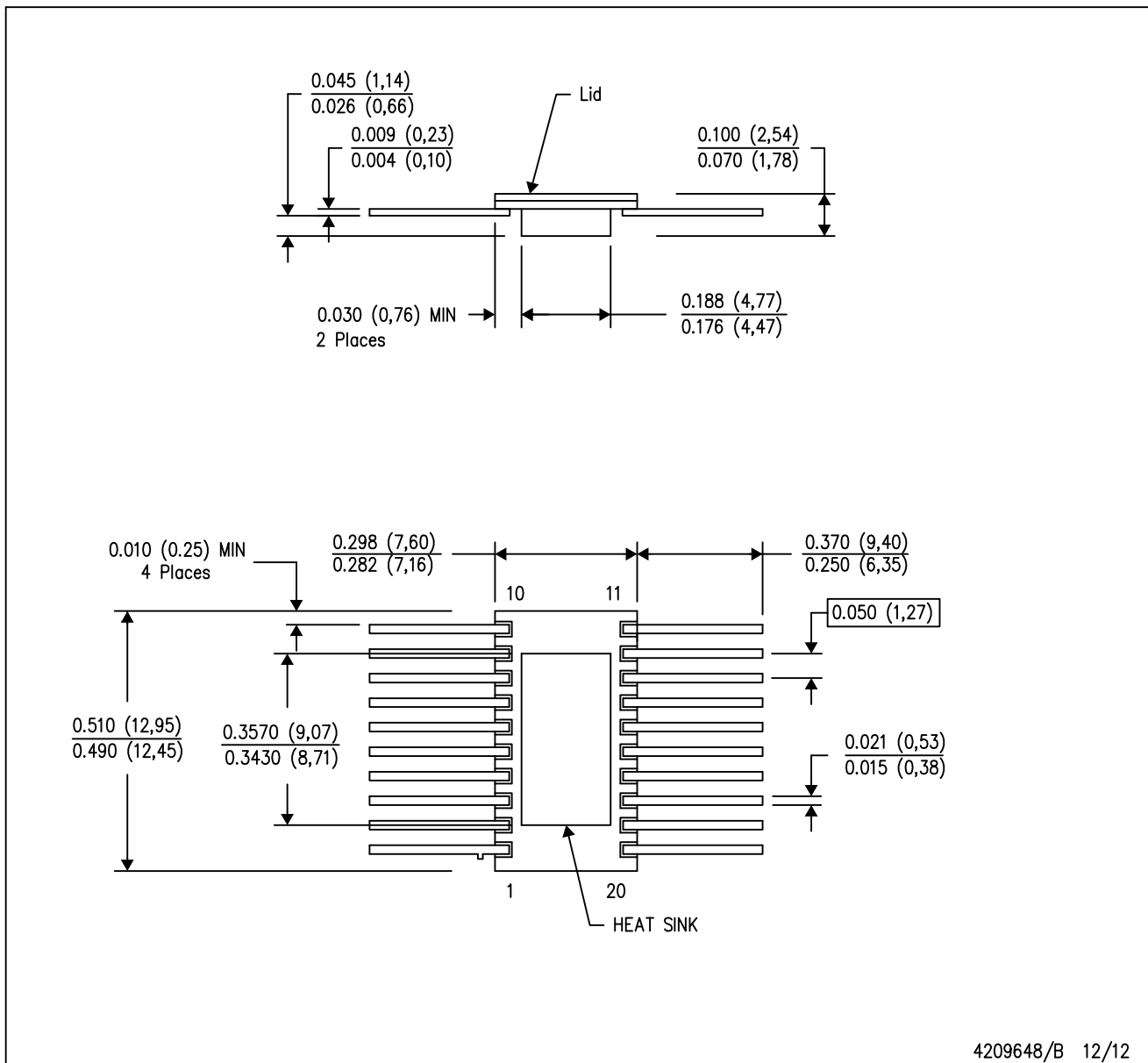

4209648/B 12/12

- NOTES:
- A. All linear dimensions are in inches (millimeters).
 - B. This drawing is subject to change without notice.
 - C. This package can be hermetically sealed with a metal lid.
 - D. The terminals will be gold plated.
 - E. Falls within MIL STD 1835 CDFP3-F20.

IMPORTANT NOTICE

Texas Instruments Incorporated and its subsidiaries (TI) reserve the right to make corrections, enhancements, improvements and other changes to its semiconductor products and services per JESD46, latest issue, and to discontinue any product or service per JESD48, latest issue. Buyers should obtain the latest relevant information before placing orders and should verify that such information is current and complete. All semiconductor products (also referred to herein as "components") are sold subject to TI's terms and conditions of sale supplied at the time of order acknowledgment.

TI warrants performance of its components to the specifications applicable at the time of sale, in accordance with the warranty in TI's terms and conditions of sale of semiconductor products. Testing and other quality control techniques are used to the extent TI deems necessary to support this warranty. Except where mandated by applicable law, testing of all parameters of each component is not necessarily performed.

TI assumes no liability for applications assistance or the design of Buyers' products. Buyers are responsible for their products and applications using TI components. To minimize the risks associated with Buyers' products and applications, Buyers should provide adequate design and operating safeguards.

TI does not warrant or represent that any license, either express or implied, is granted under any patent right, copyright, mask work right, or other intellectual property right relating to any combination, machine, or process in which TI components or services are used. Information published by TI regarding third-party products or services does not constitute a license to use such products or services or a warranty or endorsement thereof. Use of such information may require a license from a third party under the patents or other intellectual property of the third party, or a license from TI under the patents or other intellectual property of TI.

Reproduction of significant portions of TI information in TI data books or data sheets is permissible only if reproduction is without alteration and is accompanied by all associated warranties, conditions, limitations, and notices. TI is not responsible or liable for such altered documentation. Information of third parties may be subject to additional restrictions.

Resale of TI components or services with statements different from or beyond the parameters stated by TI for that component or service voids all express and any implied warranties for the associated TI component or service and is an unfair and deceptive business practice. TI is not responsible or liable for any such statements.

Buyer acknowledges and agrees that it is solely responsible for compliance with all legal, regulatory and safety-related requirements concerning its products, and any use of TI components in its applications, notwithstanding any applications-related information or support that may be provided by TI. Buyer represents and agrees that it has all the necessary expertise to create and implement safeguards which anticipate dangerous consequences of failures, monitor failures and their consequences, lessen the likelihood of failures that might cause harm and take appropriate remedial actions. Buyer will fully indemnify TI and its representatives against any damages arising out of the use of any TI components in safety-critical applications.

In some cases, TI components may be promoted specifically to facilitate safety-related applications. With such components, TI's goal is to help enable customers to design and create their own end-product solutions that meet applicable functional safety standards and requirements. Nonetheless, such components are subject to these terms.

No TI components are authorized for use in FDA Class III (or similar life-critical medical equipment) unless authorized officers of the parties have executed a special agreement specifically governing such use.

Only those TI components which TI has specifically designated as military grade or "enhanced plastic" are designed and intended for use in military/aerospace applications or environments. Buyer acknowledges and agrees that any military or aerospace use of TI components which have **not** been so designated is solely at the Buyer's risk, and that Buyer is solely responsible for compliance with all legal and regulatory requirements in connection with such use.

TI has specifically designated certain components as meeting ISO/TS16949 requirements, mainly for automotive use. In any case of use of non-designated products, TI will not be responsible for any failure to meet ISO/TS16949.

Products

Audio	www.ti.com/audio
Amplifiers	amplifier.ti.com
Data Converters	dataconverter.ti.com
DLP® Products	www.dlp.com
DSP	dsp.ti.com
Clocks and Timers	www.ti.com/clocks
Interface	interface.ti.com
Logic	logic.ti.com
Power Mgmt	power.ti.com
Microcontrollers	microcontroller.ti.com
RFID	www.ti-rfid.com
OMAP Applications Processors	www.ti.com/omap
Wireless Connectivity	www.ti.com/wirelessconnectivity

Applications

Automotive and Transportation	www.ti.com/automotive
Communications and Telecom	www.ti.com/communications
Computers and Peripherals	www.ti.com/computers
Consumer Electronics	www.ti.com/consumer-apps
Energy and Lighting	www.ti.com/energy
Industrial	www.ti.com/industrial
Medical	www.ti.com/medical
Security	www.ti.com/security
Space, Avionics and Defense	www.ti.com/space-avionics-defense
Video and Imaging	www.ti.com/video

TI E2E Community

e2e.ti.com