



# AUTOMOTIVE RELAY

## ETR GIN SERIES

### FEATURES

- 25Amp motor lock load.
- Small size with high rating.
- Single or dual version available.
- Standard type contact form SPDT and SPST are available for customer's selection.
- High performance PCB Relay.
- Comply with RoHS, REACH and ELV regulations.

### SPECIFICATIONS

Contact Resistance	Max. 100mΩ at initial value. @1A,6VDC
Contact Capacity	25 Amps at 16VDC L/R=0
Operate Time	10m Sec. Max.
Release Time	10m Sec. Max.
Dielectric Strength	Between coil & Contact: 500VAC at 50/60Hz for one minute Between Contacts: 500VAC at 50/60Hz for one minute
Insulation Resistance	100MΩ Min. at 500VDC

### COIL SPECIFICATION AT 20°C

Coil Sensitivity	Nominal Voltage (VDC)	Nominal Current (mA)	Coil Resistance (Ω±10%)	Power Consumption (W)	Pull-In Voltage (VDC)	Drop-Out Voltage (VDC)	Max. Allowable Voltage (VDC)
GIN	9	70.8	127	Abt. 0.64	60% Max.	5% Min.	130%
	12	53.3	225				
	24	26.7	900	Abt. 0.8			
	48	16.7	2880				

### ETR GIN-SH-112D



## ■ PART NUMBER SYSTEM

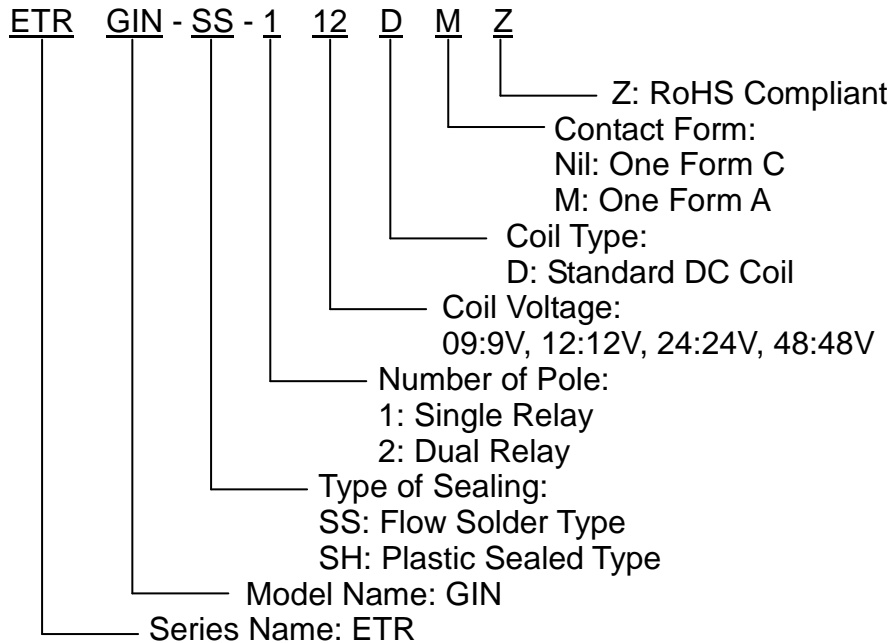

\*Marking without: "ETR" & "Z".

## ■ DIMENSIONS ( $\leq 5\text{mm} \pm 0.2\text{mm}$ , $> 5\text{mm} \pm 0.3\text{mm}$ , the tolerance of PCB thru hole: $+0.1\text{mm}$ )

