



Main

Range of product	Altivar 32
Product or component type	Variable speed drive
Product destination	Asynchronous motors Synchronous motors
Product specific application	Complex machines
Function available	-
Assembly style	With heat sink
Component name	ATV32
EMC filter	Class C2 EMC filter integrated
Network number of phases	1 phase
[Us] rated supply voltage	200...240 V - 15...10 %
Supply voltage limits	170...264 V
Supply frequency	50...60 Hz - 5...5 %
Network frequency limits	47.5...63 Hz
Motor power kW	1.1 kW 200...240 V
Motor power hp	1.5 hp 200...240 V

Complementary

Line current	13.6 A 200 V 1 phase 1.1 kW 1.5 hp 11.5 A 240 V 1 phase 1.1 kW 1.5 hp
Apparent power	2.8 kVA 240 V 1 phase 1.1 kW 1.5 hp
Prospective line I _{sc}	<= 1 kA 1 phase
Nominal output current	6.9 A 4 kHz 240 V 1.1 kW 1.5 hp
Maximum transient current	10.4 A 60 s 1.1 kW 1.5 hp
Speed drive output frequency	0.5...599 Hz
Nominal switching frequency	4 kHz
Switching frequency	2...16 kHz adjustable
Speed range	1...100 asynchronous motor in open-loop mode
Speed accuracy	+/- 10 % of nominal slip 0.2 T _n to T _n
Torque accuracy	+/- 15 %
Transient overtorque	170...200 %
Braking torque	< 170 % with braking resistor
Asynchronous motor control profile	Voltage/Frequency ratio, 2 points Voltage/Frequency ratio, 5 points Flux vector control without sensor - Energy Saving, NoLoad law Flux vector control without sensor, standard Voltage/Frequency ratio - Energy Saving, quadratic U/f
Synchronous motor control profile	Vector control without sensor
Regulation loop	Adjustable PID regulator
Motor slip compensation	Automatic whatever the load Not available in voltage/frequency ratio (2 or 5 points) Adjustable 0...300 %
Local signalling	1 LED red drive fault 1 LED red CANopen error 1 LED green CANopen run 1 LED red drive voltage
Output voltage	<= power supply voltage

Noise level	43 dB 86/188/EEC
Insulation	Electrical between power and control
Electrical connection	Screw terminal 2.5...4 mm ² AWG 12...AWG 10 power supply Removable screw terminals 1.5...2.5 mm ² AWG 14...AWG 12 motor/braking resistor Screw terminal 0.5...1.5 mm ² AWG 18...AWG 14 control
Tightening torque	0.6 N.m 5.3 lb/ft power supply 0.7 N.m 7.1 lb/ft motor/braking resistor 0.5 N.m 4.4 lb/ft control
Supply	Internal supply for reference potentiometer (1 to 10 kOhm) 10.5 V DC +/- 5 % <= 10 mA overload and short-circuit protection
Analogue input number	3
Analogue input type	Current AI3 0...20 mA (or 4-20 mA, x-20 mA, 20-x mA or other patterns by configuration) 250 Ohm 10 bits Bipolar differential voltage AI2 +/- 10 V DC 30000 Ohm 10 bits Voltage AI1 0...10 V DC 30000 Ohm 10 bits
Sampling duration	2 ms AO1 analog 2 ms AI1, AI2, AI3 analog
Response time	2 ms R2A, R2C relay 2 ms R1A, R1B, R1C relay 8 ms +/- 0.7 ms LI1...LI6 logic
Accuracy	+/- 2 % AO1 for a temperature of -10...60 °C +/- 1 % AO1 for a temperature of 25 °C +/- 0.5 % AI1, AI2, AI3 for a temperature of 25 °C +/- 0.2 % AI1, AI2, AI3 for a temperature of -10...60 °C
Linearity error	+/- 0.3 % AO1 +/- 0.2...0.5 % of maximum value AI1, AI2, AI3
Analogue output number	1
Analogue output type	Software-configurable voltage AO1 0...10 V 470 Ohm 10 bits Software-configurable current AO1 0...20 mA 800 Ohm 10 bits
Discrete output number	3
Discrete output type	Logic LO Configurable relay logic R2A, R2B NO 100000 cycles Configurable relay logic R1A, R1B, R1C NO/NC 100000 cycles
Minimum switching current	5 mA 24 V DC configurable relay logic
Maximum switching current	5 A 30 V DC resistive cos phi = 1 R2 5 A 250 V AC resistive cos phi = 1 R2 2 A 30 V DC inductive cos phi = 0.4 R1, R2 2 A 250 V AC inductive cos phi = 0.4 R1, R2 4 A 30 V DC resistive cos phi = 1 R1 3 A 250 V AC resistive cos phi = 1 R1
Discrete input number	7
Discrete input type	Safe torque off STO 24...30 V DC 1500 Ohm Switch-configurable PTC probe LI6 24...30 V DC Programmable as pulse input 20 kpps LI5 24...30 V DC level 1 PLC Programmable (sink/source) LI1...LI4 24...30 V DC level 1 PLC
Discrete input logic	Positive logic (source) LI1...LI6 < 5 V > 11 V Negative logic (sink) LI1...LI6 > 19 V < 13 V
Acceleration and deceleration ramps	S U CUS Deceleration ramp automatic stop DC injection Deceleration ramp adaptation Linear Ramp switching
Braking to standstill	By DC injection
Protection type	Thermal protection drive Short-circuit between motor phases drive Overheating protection drive Overcurrent between output phases and earth drive Input phase breaks drive
Communication port protocol	CANopen Modbus
Type of connector	1 RJ45 Modbus/CANopen on front face
Physical interface	2-wire RS 485 Modbus
Transmission frame	RTU Modbus
Type of polarization	No impedance Modbus

Number of addresses	1...247 Modbus 1...127 CANopen
Method of access	Slave CANopen
Electromagnetic compatibility	Voltage dips and interruptions immunity test IEC 61000-4-11 Radiated radio-frequency electromagnetic field immunity test level 3 IEC 61000-4-3 Electrostatic discharge immunity test level 3 IEC 61000-4-2 Electrical fast transient/burst immunity test level 4 IEC 61000-4-4 Conducted radio-frequency immunity test level 3 IEC 61000-4-6 1.2/50 µs - 8/20 µs surge immunity test level 3 IEC 61000-4-5
Width	60 mm
Height	325 mm
Depth	245 mm
Product weight	2.9 kg
Option card	Communication card Profibus DP V1 Communication card Ethernet/IP Communication card DeviceNet Communication card CANopen open style Communication card CANopen daisy chain

Environment

Standards	EN 55011 class A group 1 EN 61800-3 environments 1 category C2 EN 61800-3 environments 2 category C2 EN/IEC 61800-3 EN/IEC 61800-5-1
Product certifications	CSA C-Tick GOST NOM 117 UL
Marking	CE
Pollution degree	2 EN/IEC 61800-5-1
IP degree of protection	IP20 EN/IEC 61800-5-1
Vibration resistance	1.5 mm peak to peak 3...13 Hz EN/IEC 60068-2-6 1 gn 13...200 Hz EN/IEC 60068-2-6
Shock resistance	15 gn 11 ms EN/IEC 60068-2-27
Relative humidity	5...95 % without dripping water IEC 60068-2-3 5...95 % without condensation IEC 60068-2-3
Ambient air temperature for operation	50...60 °C with derating factor -10...50 °C without derating
Ambient air temperature for storage	-25...70 °C
Operating altitude	1000...2000 m with current derating 1 % per 100 m <= 1000 m without derating
Operating position	Vertical +/- 10 degree

Offer Sustainability

Sustainable offer status	Not Green Premium product
RoHS (date code: YYWW)	Compliant - since 1007 - Schneider Electric declaration of conformity
Product environmental profile	Available Download Product Environmental
Product end of life instructions	Available Download End Of Life Manual

Size B

Dimensions

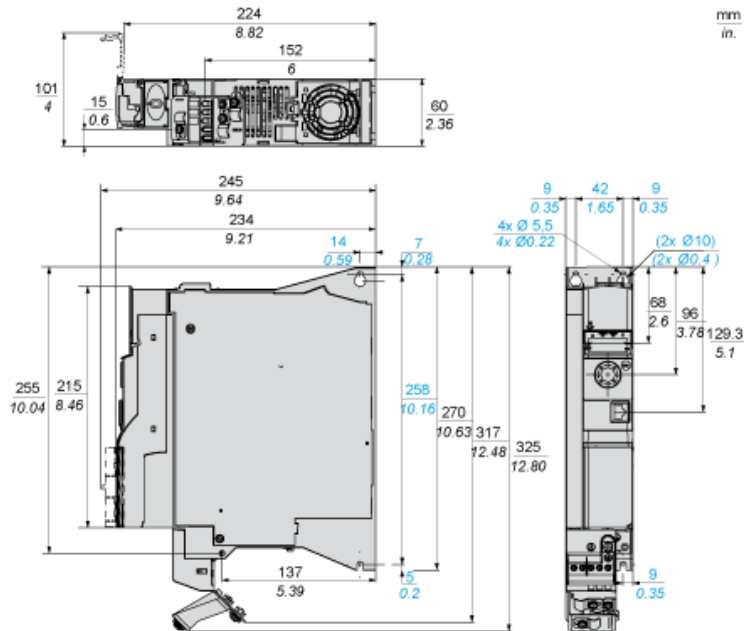

Mounting and Clearance

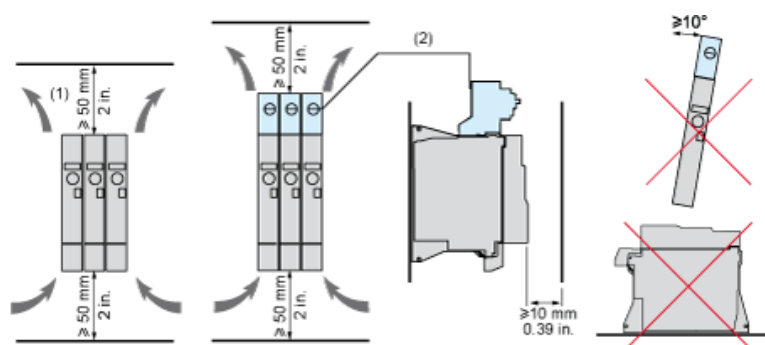

- (1) Minimum value corresponding to thermal constraints. A 150 mm clearance may help to connect the ground.
- (2) Optional GV2 circuit-breaker

Option: Protection Device, GV2 circuit-breaker

The drive is prepared to be equipped with an optional GV2 circuit-breaker.

The GV2 circuit-breaker is directly mounted on the drive. Mechanical and electrical link are made using the optional adapter. The options are supplied with detailed mounting instruction sheet.

NOTE: The product overall dimension, including GV2 adapter and EMC plate mounted, becomes 424 mm (16.7 in.)

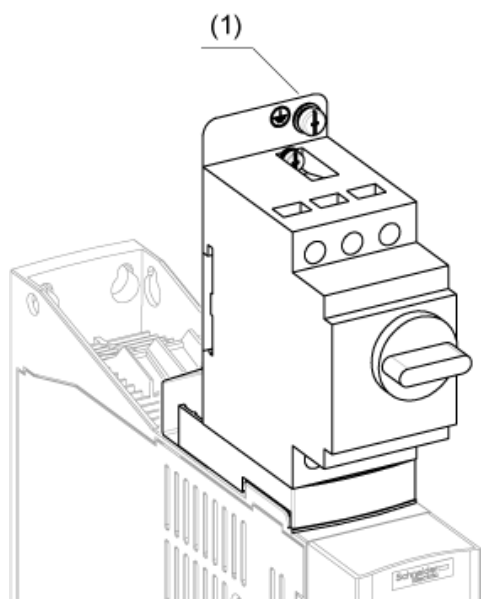

- (1) Ground screw (HS type 2 - 5x12)

Connection Diagrams

Single or Three-phase Power Supply - Diagram with Line Contactor

Connection diagrams conforming to standards EN 954-1 category 1 and IEC/EN 61508 capacity SIL1, stopping category 0 in accordance with standard IEC/EN 60204-1.

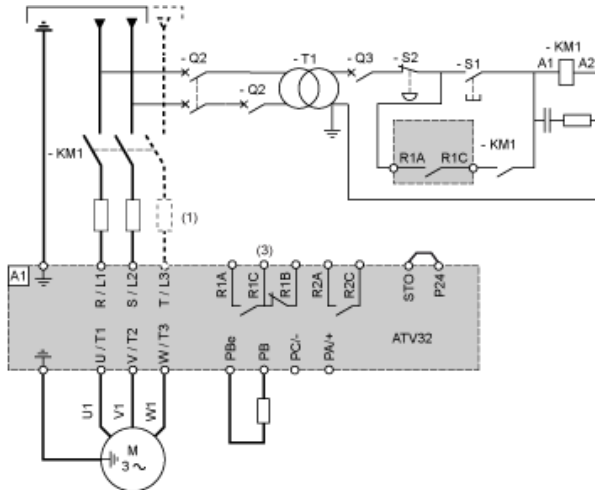

- (1) Line choke (if used)
- (3) Fault relay contacts, for remote signaling of drive status

Single or Three-phase Power Supply - Diagram with Switch Disconnect

Connection diagrams conforming to standards EN 954-1 category 1 and IEC/EN 61508 capacity SIL1, stopping category 0 in accordance with standard IEC/EN 60204-1.

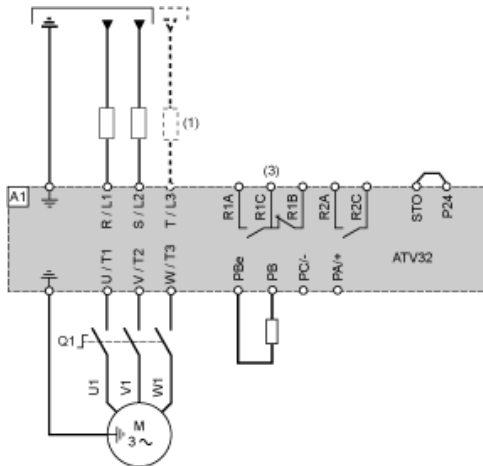

- (1) Line choke (if used)
- (3) Fault relay contacts, for remote signaling of drive status

Diagram with Preventa Safety Module (Safe Torque Off Function)

Connection diagrams conforming to standards EN 954-1 category 3 and IEC/EN 61508 capacity SIL2, stopping category 0 in accordance with standard IEC/EN 60204-1.

When the emergency stop is activated, the drive power supply is cut immediately and the motor stops in freewheel, according to category 0 of standard IEC/EN 60204-1.

A contact on the Preventa XPS AC module must be inserted in the brake control circuit to engage it safely when the STO (Safe Torque Off) safety function is activated.

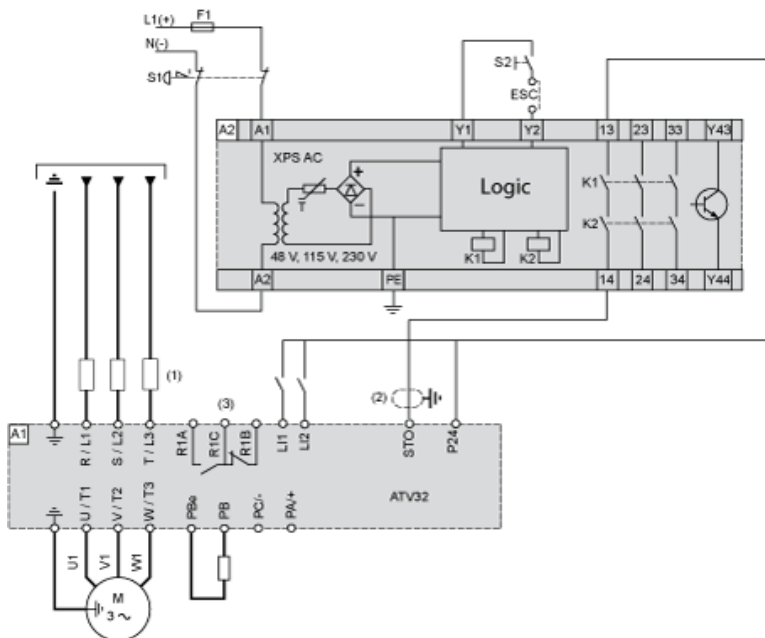

- (1) Line choke (if used)
- (2) It is essential to connect the shielding to the ground.
- (3) Fault relay contacts, for remote signaling of drive status

The STO safety function integrated into the product can be used to implement an "EMERGENCY STOP" (IEC 60204-1) for category 0 stops. With an additional, approved EMERGENCY STOP module, it is also possible to implement category 1 stops.

STO function

The STO safety function is triggered via 2 redundant inputs. The circuits of the two inputs must be separate so that there are always two channels. The switching process must be simultaneous for both inputs (offset < 1 s).

The power stage is disabled and an error message is generated. The motor can no longer generate torque and coasts down without braking. A restart is possible after resetting the error message with a "Fault Reset".

The power stage is disabled and an error message is generated if only one of the two inputs is switched off or if the time offset is too great. This error message can only be reset by switching off the product.

Diagram without Preventa Safety Module

Connection diagrams conforming to standards EN 954-1 category 2 and IEC/EN 61508 capacity SIL1, stopping category 0 in accordance with standard IEC/EN 60204-1.

The connection diagram below is suitable for use with machines with a short freewheel stop time (machines with low inertia or high resistive torque).

When the emergency stop is activated, the drive power supply is cut immediately and the motor stops in freewheel, according to category 0 of standard IEC/EN 60204-1.

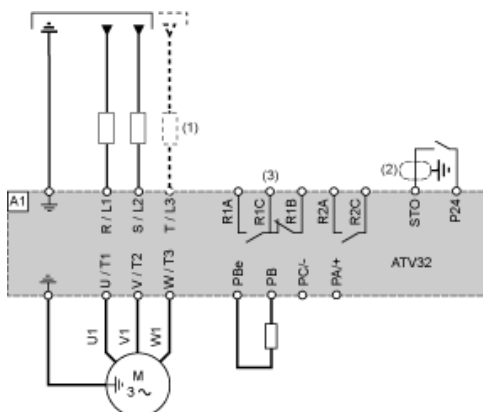

- (1) Line choke (if used)
- (2) It is essential to connect the shielding to the ground.
- (3) Fault relay contacts, for remote signaling of drive status

The STO safety function integrated into the product can be used to implement an "EMERGENCY STOP" (IEC 60204-1) for category 0 stops.

Control Connection Diagram in Source Mode

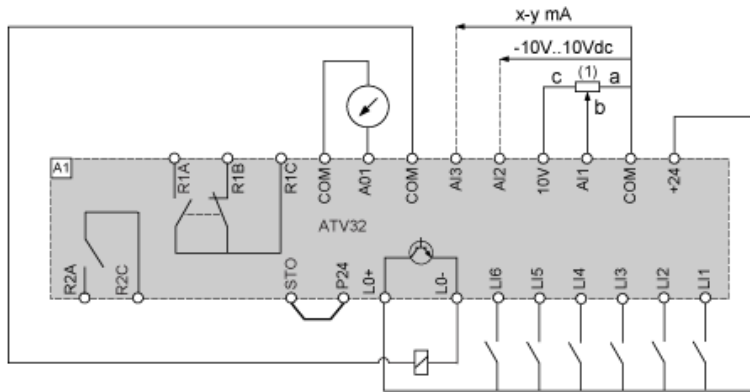

(1) Reference potentiometer SZ1RV1202 (2.2 kΩ) or similar (10 kΩ maximum)

Derating Curves

Derating curve for the nominal drive current (I_n) as a function of temperature and switching frequency.

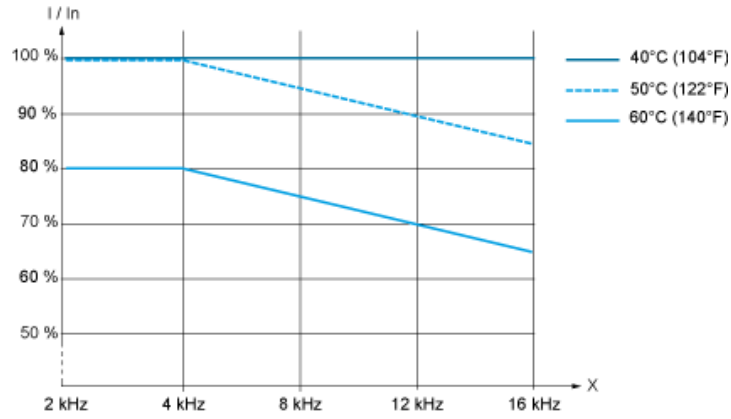

X Switching frequency

Above 4 kHz, the drive will reduce the switching frequency automatically in the event of an excessive temperature rise.

Sink / Source Switch Configuration (SW1)

The logic input switch (SW1) is used to adapt the operation of the logic inputs to the technology of the programmable controller outputs.
 Switch SW1 set to "Source" position

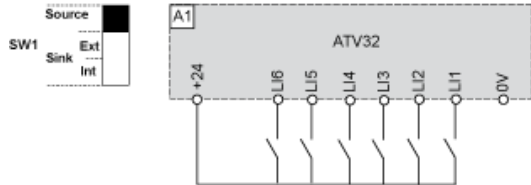

Switch SW1 set to "Source" position and use of an external power supply for the LIs

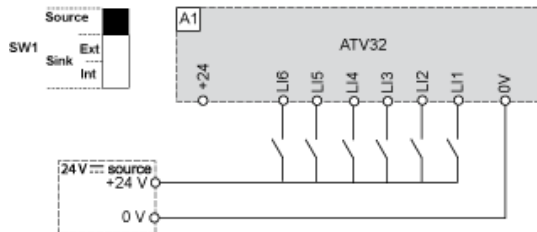

Switch SW1 set to "Sink Int" position

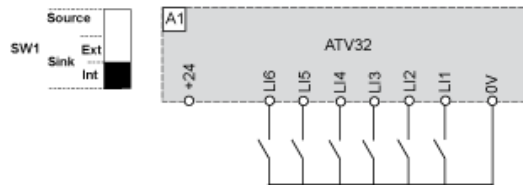

Switch SW1 set to "Sink Ext" position

