

2-GHz Single Balanced Mixer

Description

The U2796B-FP is a 2-GHz down conversion mixer for telecommunication systems, e.g. cellular radio, CT1, CT2, DECT, PCN, using TEMIC Semiconductors advanced bipolar technology. The U2796B is well suited

for the receiver portion of the RF circuit. Single balanced structure has been chosen for the best noise performance and low current consumption. The IIP3 is programmable.

Features

- Supply voltage range: 2.7 to 5.5 V
- Excellent isolation characteristics
- Low current consumption: 3.2 mA without R_{IP3}
- IIP3 programmable
- Input frequency operating range up to 2 GHz
- RF characteristic nearly independent of supply voltage

Benefits

- Stand alone product
- Low current consumption extends talk time
- 3-V operation requires small space for batteries

Block Diagram

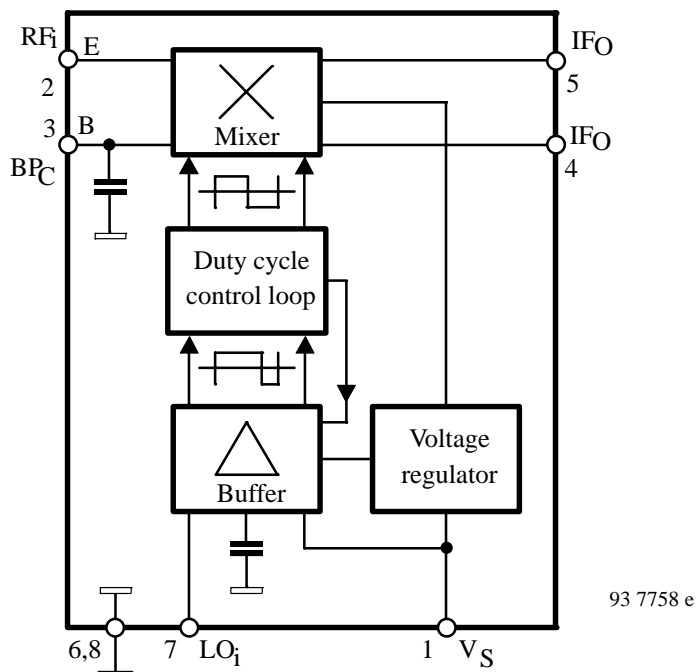
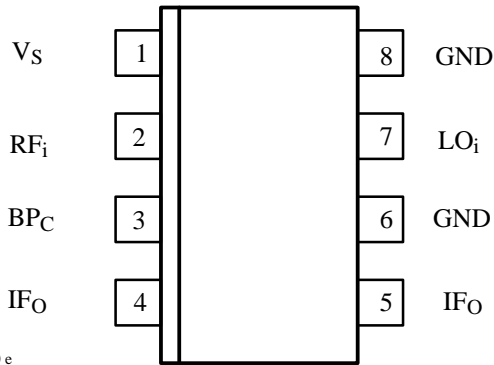

Figure 1.

Pin Description



93 7820 e

Figure 2.

Pin	Symbol	Function
1	V_S	Supply voltage
2	RF	RF input and IIP3 programming port
3	BP_C	By-pass capacitor
4	IF_o	IF output
5	IF_o	IF output
6	GND	Ground
7	LO_i	Local oscillator input
8	GND	Ground

Absolute Maximum Ratings

Parameters	Symbol	Value	Unit
Supply voltage Pin 1	V_S	6	V
Input voltage Pins 2, 3, 4, 5 and 7	V_i	0 to V_S	V
Junction temperature	T_j	125	°C
Storage temperature	T_{stg}	-40 to +125	°C

Operating Range

Parameters	Symbol	Value	Unit
Supply voltage range Pin 1	V_S	2.7 to 5.5	V
Ambient temperature	T_{amb}	-40 to +85	°C

Thermal Resistance

Parameters	Symbol	Value	Unit
Junction ambient SO8	R_{thJA}	175	K/W

Electrical Characteristics

Test conditions (unless otherwise specified):

$V_S = 3\text{ V}$, $f_{LO} = 900\text{ MHz}$; $I_M = 1.2\text{ mA}$, $T_{amb} = 25^\circ\text{C}$. System impedance $Z_O = 50\ \Omega$

Parameters	Test conditions / Pin	Symbol	Min.	Typ.	Max.	Unit
Supply voltage	Pin 1	V_S	2.7		5.5	V
Supply current	$R_{IP3} = \infty$, Pin 1	I_S	2.8	3.2	3.7	mA
Conversion power gain Figure 4	$R_L = 3\text{ k}\Omega$, $R_{IP3} = \infty$ $f_{LO} = 900\text{ MHz}$	P_{GC}		9		dB
	$f_{LO} = 1700\text{ MHz}$ $f_{IF} = 45\text{ MHz}$			9		
Isolation						
LO-spurious at RF_{in}	$P_{iLO} = -10\text{ dBm}$ Figure 5 Pin 7 to 2	IS_{LORF}			-35	dBm
RF to LO Figure 6	$P_{iRF} = -25\text{ dBm}$ Pin 2 to 7 $f_{LO} = 900\text{ MHz}$	IS_{RFLO}	30	40		dB
	$f_{LO} = 1700\text{ MHz}$			20		
Operating frequencies						
RF frequency	Pin 2	RF_i	2000			MHz
LO_{in} frequency	Pin 7	LO_i	2000			MHz
IF_{out} frequency	Pins 4 and 5	IF_o	300			MHz
Input level						
RF input (-1 dB comp.)	$R_L = 50\ \Omega$, Pin 2	P_{iRF}		-15		dBm
3rd order intercept point	$P_{iLO} = -10\text{ dBm}$, $R_{IP3} = \infty$ Figure 2 Pin 2	$IIP3$		-4		dBm
LO input	Pin 7	P_{iLO}		-6	0	dBm
Impedances						
RF input	Pin 2	Z_{iRF}		25		Ω
LO input	Pin 7	Z_{iLO}		50		Ω
IF output	Pins 4 and 5	Z_{oIF}		> 10 k Ω // 0.9 pF		
Noise figure (DSB) Figure 7	$P_{iLO} = 0\text{ dBm}$, $R_L > 3\text{ k}\Omega$ $f_{LO} = 900\text{ MHz}$	NF_{50}		9		dB
	$f_{LO} = 1700\text{ MHz}$			12		
Voltage standing wave ratio LO	Pin 7	VSWR- LO		1.3	2	

Note: I_M = Internal mixer current (see figure 2)

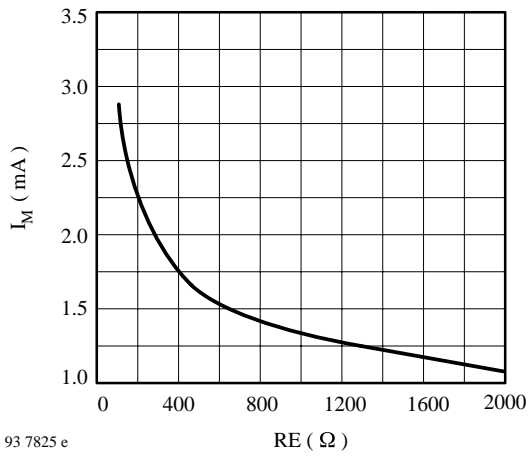

Figure 3. Mixer current (I_M) versus RE

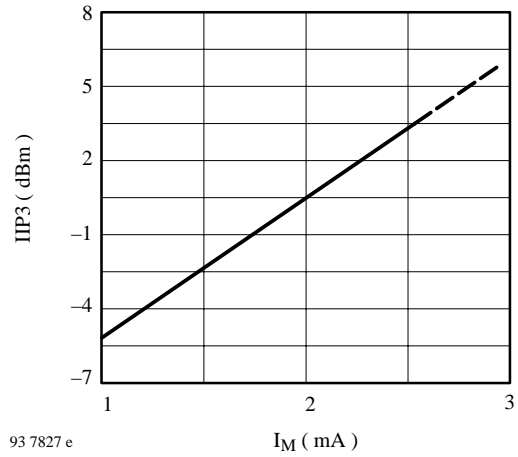

Figure 4. Third-order input intercept IIP3 point versus I_M

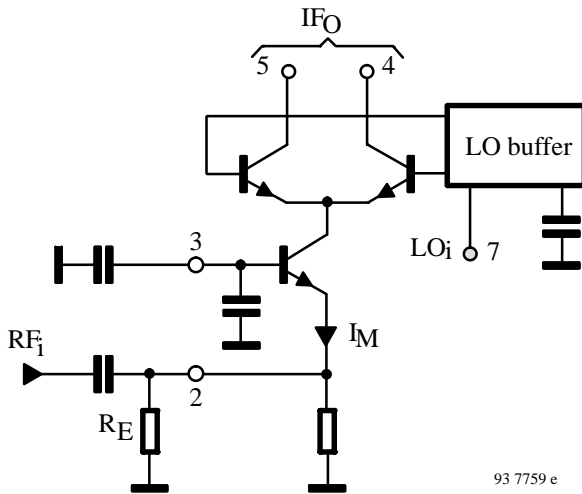
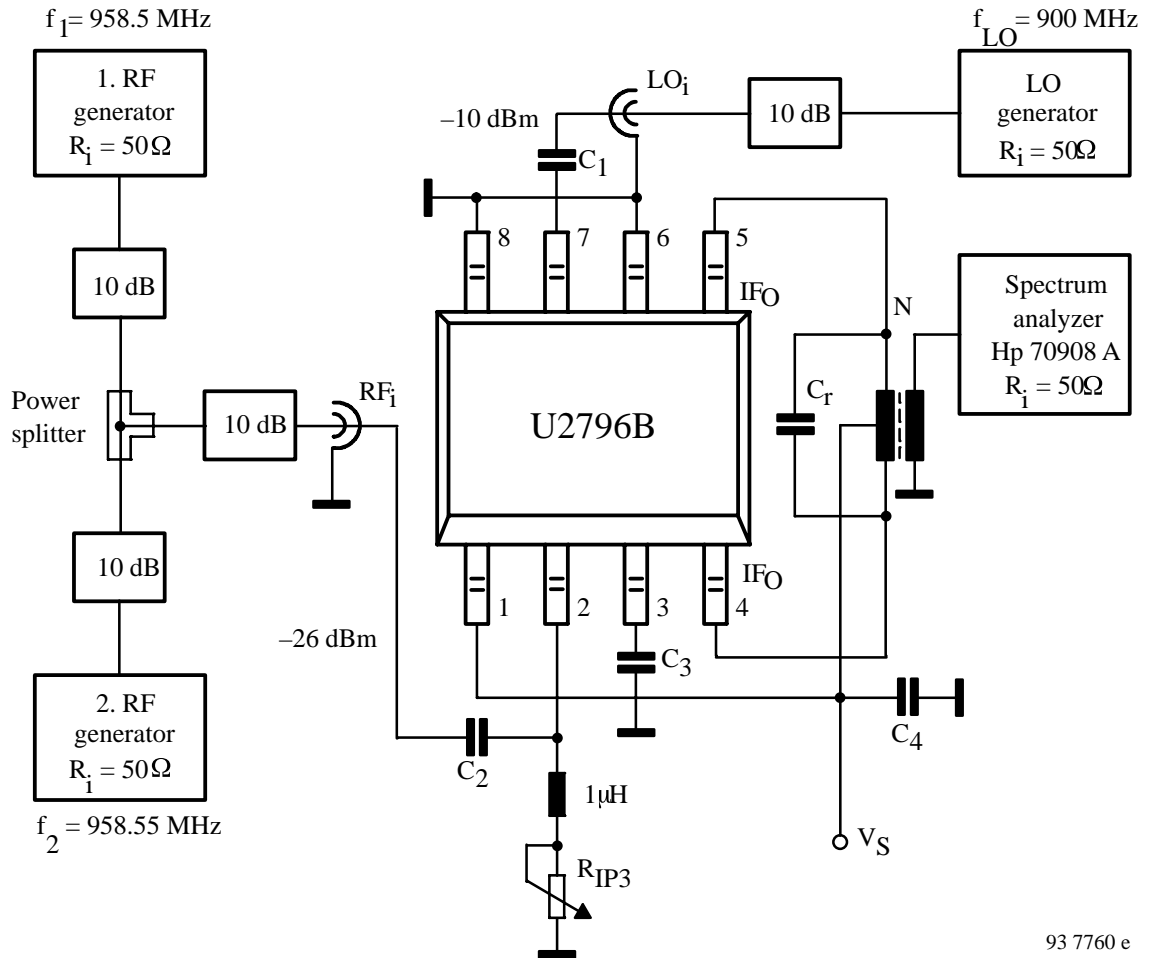

Figure 5. Mixer circuitry



93 7760 e

Figure 6. Test circuit-conversion power gain (PG_C) and 3rd order input intercept point (IIP3)

93 7761 e

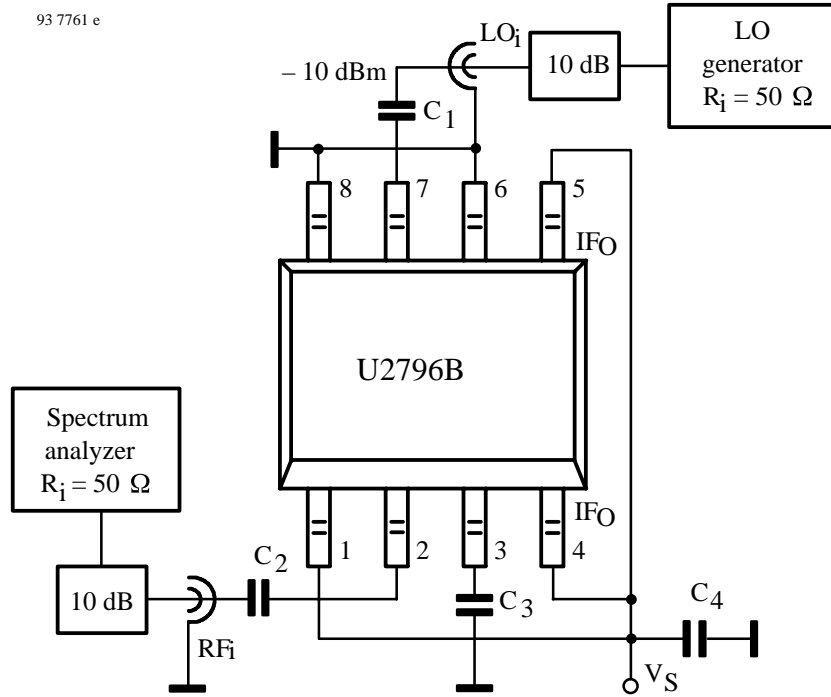
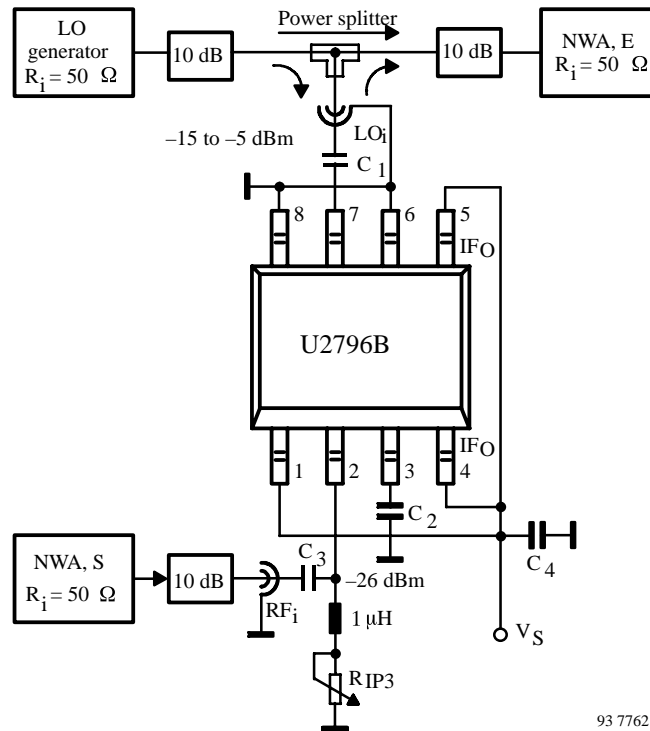
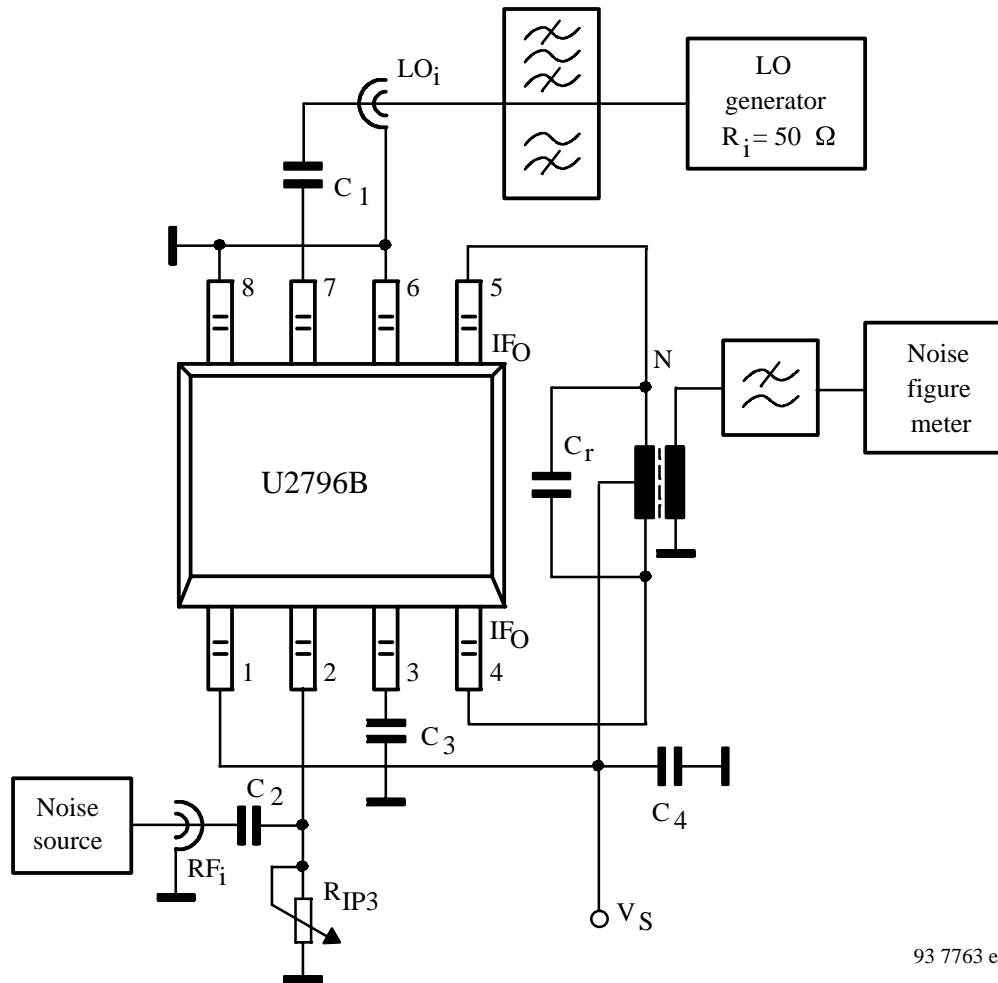

Figure 7. Test circuit-isolation LO to RF



93 7762 e

Figure 8. Test circuit-isolation RF to LO



93 7763 e

Figure 9. Test circuit-noise figure

Note:

1. The noise floor of the LO generator might influence the noise figure test result. In order to avoid this, either a band pass or a high pass filter with $f_c > f_{IF}$ should be implemented.
2. If IF output network does not provide sufficient suppression of the LO component, a low pass filter should be inserted to avoid overdriving the noise figure meter.
3. For best noise performance 0 dBm LO power level is required.

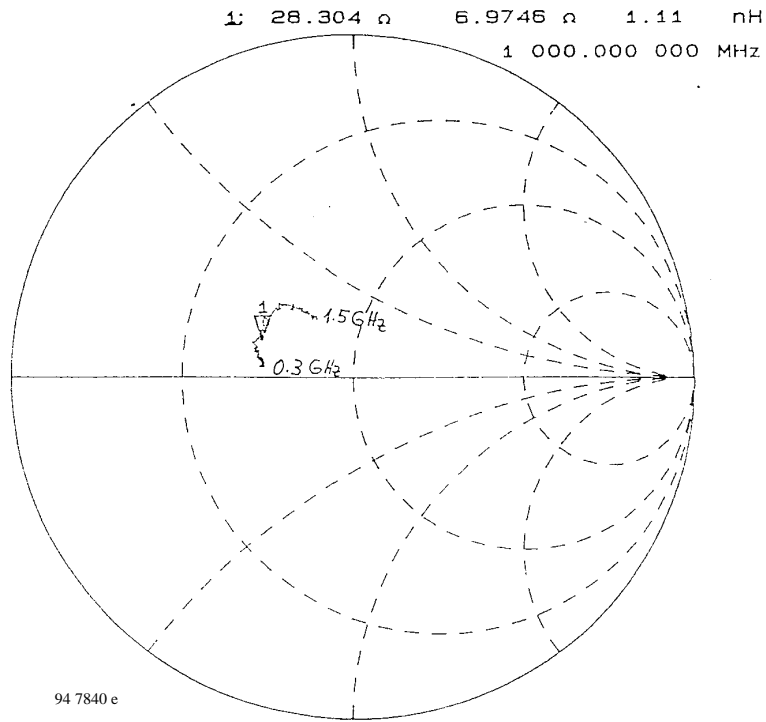

Figure 10. S11 RF input impedance

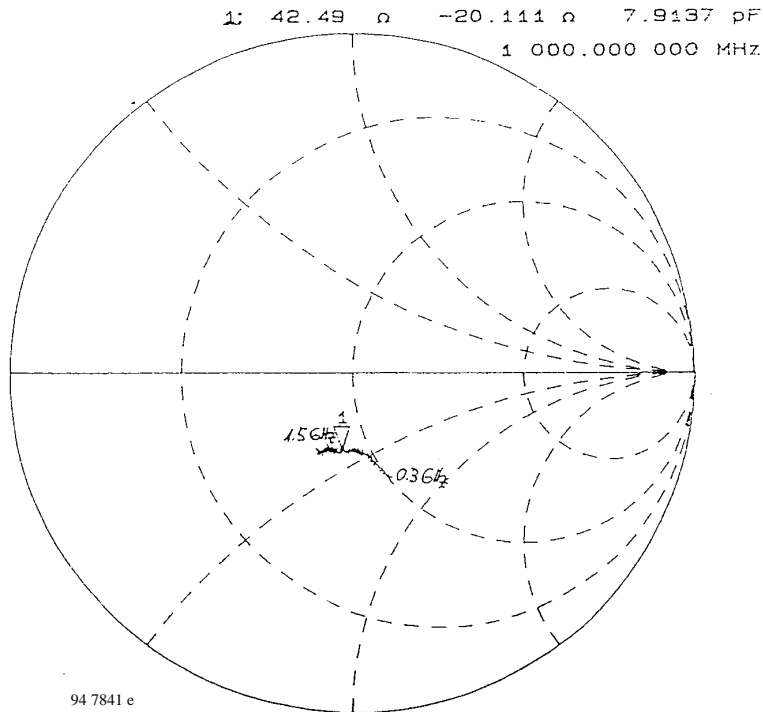

Figure 11. S11 LO input impedance

Application Circuit

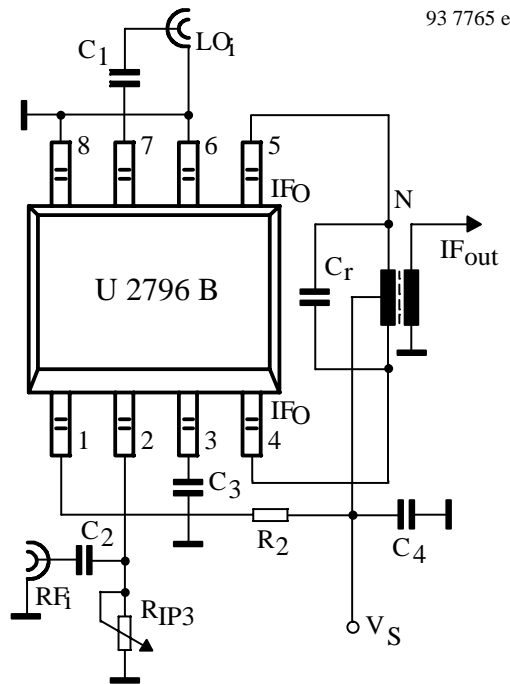

Figure 12.

Recommended Values for the Evaluator

C_1 and $C_2 = 150$ pF, C_3 and $C_4 = 100$ nF. C_r is calculated for resonance with the balun at f_{IF} , or as a high pass filter for f_{LO} . The output balun transformer ratio $> = 8:1$ for $Z_0 = 50 \Omega$. R_2 increases the IF output level and is calculated from:

$$R_2 = \frac{V_S(4,5) - V_S(1)}{I_S(1)}$$

For example $V_S(4,5) = 4$ V, $V_S(1) = 3$ V, $I_S(1) = 2.2$ mA
 $R_2 \approx 470 \Omega$, where $I_S(1)$ is the current consumption without the mixer stage.

impedance of a subsequent filter is $1 \text{ k}\Omega$, the capacitive voltage divider may be left out.

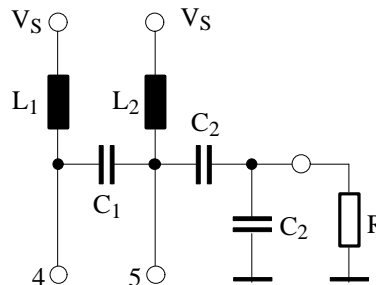

Application Hint

The output transformer at the pins 4 and 5 can be replaced by LC-circuits like one of the following proposals, which are saving space compared to the transformer and are suitable for higher IF frequencies. When applying one of these solutions, it has to be checked whether the requirements on noise figure and gain can be achieved.

The second circuit was dimensioned for approximately 130 MHz and a load resistance of 50Ω . If for instance the

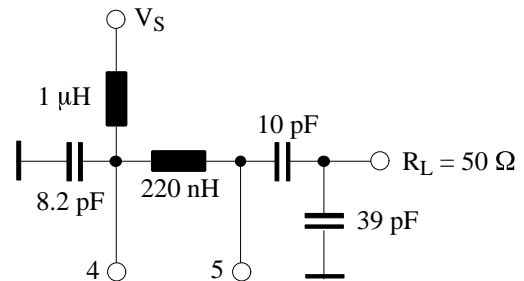

Figure 13.

Evaluation Board

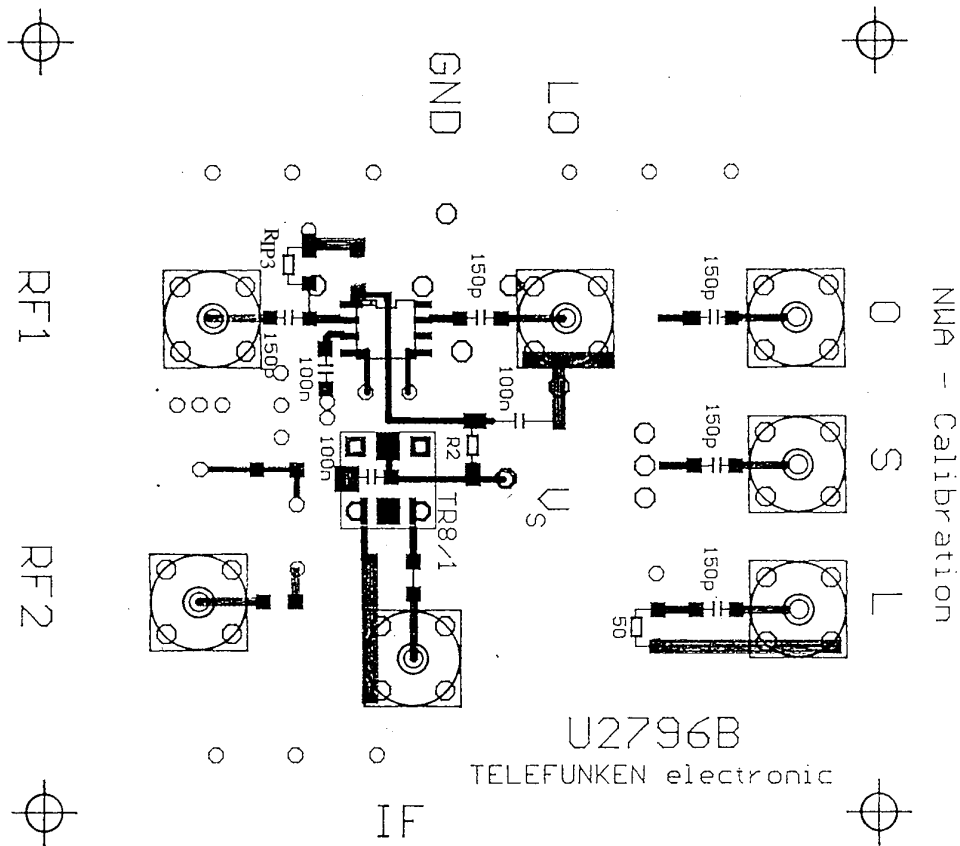

Figure 14.

93 7826 e

Dimensions in mm

Package SO8

Dimensions in mm

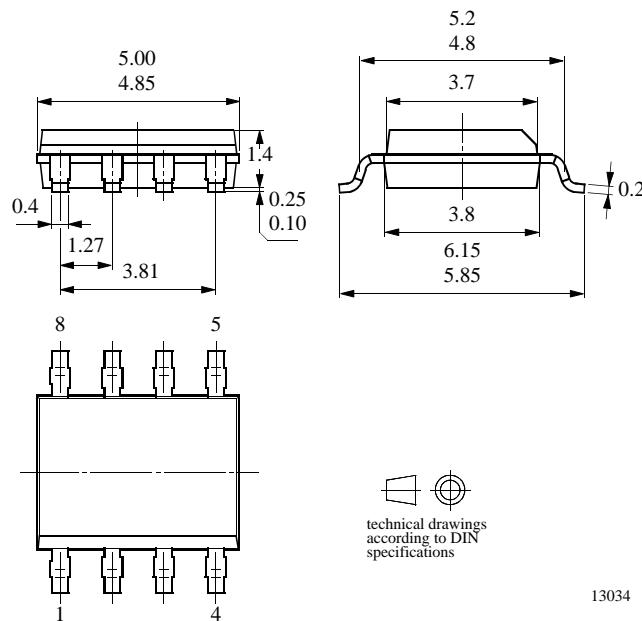

13034

Ozone Depleting Substances Policy Statement

It is the policy of **TEMIC Semiconductor GmbH** to

1. Meet all present and future national and international statutory requirements.
2. Regularly and continuously improve the performance of our products, processes, distribution and operating systems with respect to their impact on the health and safety of our employees and the public, as well as their impact on the environment.

It is particular concern to control or eliminate releases of those substances into the atmosphere which are known as ozone depleting substances (ODSs).

The Montreal Protocol (1987) and its London Amendments (1990) intend to severely restrict the use of ODSs and forbid their use within the next ten years. Various national and international initiatives are pressing for an earlier ban on these substances.

TEMIC Semiconductor GmbH has been able to use its policy of continuous improvements to eliminate the use of ODSs listed in the following documents.

1. Annex A, B and list of transitional substances of the Montreal Protocol and the London Amendments respectively
2. Class I and II ozone depleting substances in the Clean Air Act Amendments of 1990 by the Environmental Protection Agency (EPA) in the USA
3. Council Decision 88/540/EEC and 91/690/EEC Annex A, B and C (transitional substances) respectively.

TEMIC Semiconductor GmbH can certify that our semiconductors are not manufactured with ozone depleting substances and do not contain such substances.

We reserve the right to make changes to improve technical design and may do so without further notice.

Parameters can vary in different applications. All operating parameters must be validated for each customer application by the customer. Should the buyer use TEMIC products for any unintended or unauthorized application, the buyer shall indemnify TEMIC against all claims, costs, damages, and expenses, arising out of, directly or indirectly, any claim of personal damage, injury or death associated with such unintended or unauthorized use.

TEMIC Semiconductor GmbH, P.O.B. 3535, D-74025 Heilbronn, Germany
Telephone: 49 (0)7131 67 2594, Fax number: 49 (0)7131 67 2423