

1 2 3 4 5 6 7 8 9 10

A

B

C

D

E

F

G

A

B

C

D

E

F

G

目錄 <b>MAPX</b>	設變內容 <b>MODIFICATION</b>	日期 <b>DATE</b>

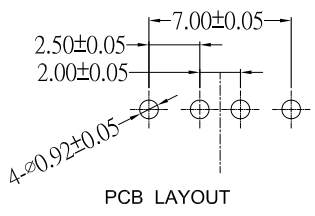
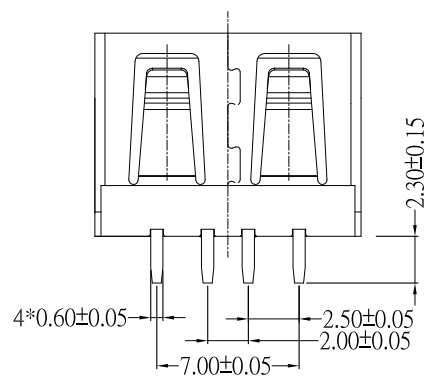
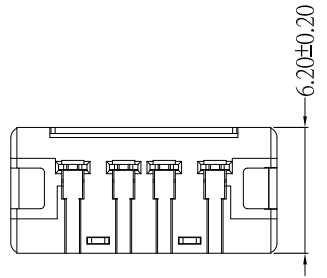
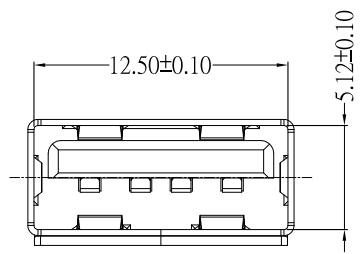
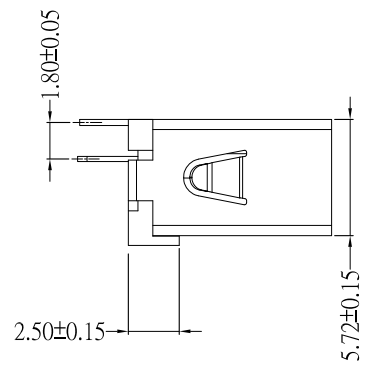
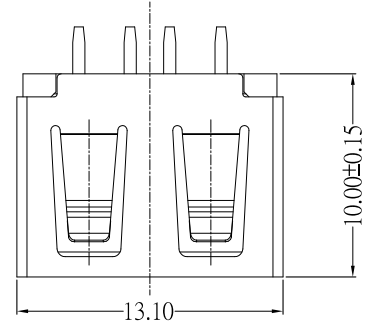

NOTES:

- 1. HOUSING: SEE NOTES,
- TERMINAL: SEE NOTES.
- SHELL: SEE NOTES.

SPECIFICATION:

- 1. ELECTRICAL CHARACTERISTIC:
  - CONTACT RESISTANCE: 30MΩ MAX
  - DIELECTRIC WITHSTANDING VOLTAGE: 500V AC FOR 1MIN
  - INSULATION RESISTANCE: 1000MΩ MIN
- 2. MECHANICAL CHARACTERISTIC:
  - INSERTION FORCE: 35N(3.57KGF) MAX
  - EXTRACTION FORCE: 10~35N(1.02~3.57KGF)MIN
  - DURABILITY: 1500 CYCLES EXTRACTION FORCE:10~35N
- 3. ENVIRONMENTAL:
  - OPERATING TEMPERATURE: -55℃+85℃
- 4. Contact finish:
  - 01:Selective Gold Flash
  - 02:Selective Gold 3U"
  - 03:Selective Gold 5U"
  - 04:Selective Gold 15U"
  - 05:Selective Gold 30U"

产品图 PRODUCT CHART DWG				深圳市精拓金电子有限公司							
公差一览表 TOLERANCE UNLESS OTHERWISE				单位 UNITS	MM	制图 DRAWING	Z-Y-B	产品料号 PRODUCT PART NO.	910-451A101BY10200		
X.	±0.25	X'	±5°	比例 SCALE	1:1	审核 CHKD	雷永键	产品名称 PRODUCT NO.	AF10.0C款180度无脚无边铁壳一型		
.X	±0.20	.X'	±2°						PBT白胶		
.XX	±0.15	.XX'	±1°	日期 DATE	2013.05.10	核准 APPD	雷永键	角法 VIEW		版本 VER	A0
.XXX	±0.10	.XXX'	±0.5°								

1 2 3 4 5 6 7 8 9 10