

IEEE802.11n/a/b/g
Wireless LAN (Access point / Station)

FXA3000 Series

FXA3000-US FXA3000-EU
FXA3000-TW FXA3000-KR



* Specifications, color and design of the products are subject to change without notice.

Features

Compatible with 4 standards, IEEE802.11n/a/b/g

You can choose 24 ch (W52/W53/W56/W58 *1) in the 5 GHz (IEEE802.11n/a), and in the 2.4 GHz (IEEE802.11n/b/g), you can choose from 1 to 13ch *2. So, it is possible to design a flexible wireless network to adjust a radio wave interference.

Light weight and compact design for installation setting and sophisticated appearance

Compatible with PoE and include an antenna inside chassis considering installation setting and sophisticated appearance. This product can be used at variety of setting using included magnets and tapping screws.

Supports a various power supply

This product supports an AC adapter (sold separately), DC power supplies from 5 to 30 VDC, and power supplied from the LAN connector.

This product can be switched between access point (master station), station (slave station), and repeater operation modes.

By switching the operation mode, you can use this product as not only an access point (a master station) but also as a station (a slave station) and a repeater. You can use this product as a wireless LAN converter for a wired LAN device.

The proprietary encryption technology "WSL" that is available along with WPA2/WPA and WEP.

In addition to the certifications for advanced security standards WPA2/WPA and IEEE802.1X, this product is also equipped with our proprietary encryption technology "WSL", which can be used at the same time as these certifications. MAC address filtering and ESSID hiding are also supported.

Features variety of functions, including VLAN and a virtual AP function

This product is equipped with a VLAN function for constructing virtual networks and a virtual AP function for operating one AP as multiple virtual APs with different security settings. Also, large capacity event logs (with approximately 15,000 events, which is 7 times our conventional products) can be saved.

Supported with a connector protection cover and security wire connection configuration

This product can be protected from theft by protecting connectors with included connector cover and attaching a security wire to security slot.

*1: W52: 36, 40, 44, 48ch / W53: 52, 56, 60, 64ch / W56: 100, 104, 108, 112, 116, 120, 124, 128, 132, 136, 140ch / W58: 149, 153, 157, 161, 165ch

Supported channels are different depending on the country in which the product is used.

*2: Supported channels are different depending on the country in which the product is used.

The FXA3000 Series is an access point that conforms to IEEE 802.11n/a/b/g wireless networking standards and that supports a wide range of input power (5 to 30 VDC) and PoE.

Light weight and compact design enables a smart installation with included magnets and tapping screws.

This product is supported with a connector protection cover and a security slot for theft proof.

- * The contents in this document are subject to change without notice.
- * Visit the CONTEC website to check the latest details in the document.
- * The information in the data sheets is as of October, 2018.

Specification

Function specification

| Name | Specification |
|---|---|
| Unit Type | Access point / Station / Repeater |
| Wired LAN | |
| Ethernet standard | IEEE802.3(10BASE-T), IEEE802.3u(100BASE-TX), IEEE802.3af |
| Port Speed / Communication type / Number of ports | 10/100Mbps/Half Duplex, Full Duplex / 1 |
| Wireless LAN | |
| Wireless Networking Standard | IEEE802.11n, IEEE802.11a, IEEE802.11b, IEEE802.11g |
| Channel | Varies depending on the country in which the product is used. |
| IEEE802.11n | |
| Data transmission speed *1 | 300 - 65Mbps(MSC0 - 15, Short/Long GI) (Fixed/Auto) |
| IEEE802.11a | |
| Data transmission speed *1 | 54, 48, 36, 24, 18, 12, 9, 6Mbps (Fixed/Auto) |
| IEEE802.11b | |
| Data transmission speed *1 | 11, 5.5, 2, 1Mbps (Fixed/Auto) |
| IEEE802.11g | |
| Data transmission speed *1 | 54, 48, 36, 24, 18, 12, 9, 6Mbps (Fixed/Auto) |
| Security | |
| IEEE802.11n | WPA(AES), WPA2(AES), WPA-PSK(AES), WPA2-PSK(AES), WSL(combination mentioned above are possible) |
| IEEE802.11a/b/g | WEP(Open/ Shared Key /Auto), WPA(AES, TKIP), WPA-PSK(AES,TKIP), WPA2(AES, TKIP), WPA2-PSK(AES,TKIP), IEEE802.1X(EAP-TLS, PEAP), WSL(combination mentioned above are possible) |
| Antenna | chip-antenna×2 MIMO |
| External dimension (mm) | Unit only: 136.2(W) x 100.0(D) x 31.0(H) including power cable disconnection prevention hook With connector cover attached: 170.0(W) x 100.0(D) x 31.0(H) |
| Weight | 220g (Unit only), 250g (With connector cover attached) |

*1 These are theoretical values based on their respective wireless LAN standards; they do not indicate actual data transfer rates.

Installation Environment Requirements

| Name | Specification |
|-----------------------------------|--|
| Input voltage range | 5VDC±5% (DC Jack), 5 - 30VDC±5% (power connector), 36 - 57VDC (PoE) |
| Rating input current | 0.83A (5VDC input), 0.15A (30VDC input) (Max), 0.13A (PoE input 48V) |
| Operating ambient temperature | 0 - 40°C |
| Operating ambient humidity | 10 - 90%RH (No condensation) |
| Floating dust particles | Not extreme |
| Corrosive gases | None |
| Permitted transient power failure | 17ms or less (100VAC@25°C) An automatic reset is performed when low voltage is detected. |
| Approval standards | FXA3000-US FCC, IC, WPC, IMDA, UL/cUL, RoHS Compliant FXA3000-EU CE Marking (RE, RoHS), NBTC FXA3000-TW NCC, RoHS Compliant FXA3000-KR KC, RoHS Compliant |

Packing List

- Main unit (One of the followings)
[FXA3000-US, FXA3000-EU, FXA3000-KR, FXA3000-TW] ...1
- Setup Guide * ... 1
- Magnet ...1
- Tapping Screws ...2
- Connector cover (Installed in unit) ...1
- Serial Number Label ...1
- CE Declaration ...1 (FXA3000-EU only)

* The language of the Setup Guide varies depending on the product.

External Dimensions

Unit only

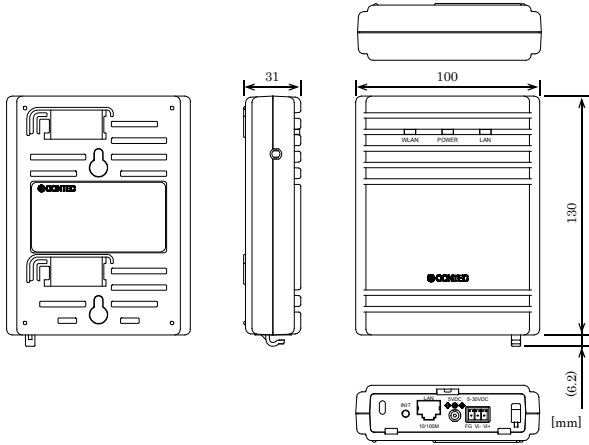

Connector cover attached

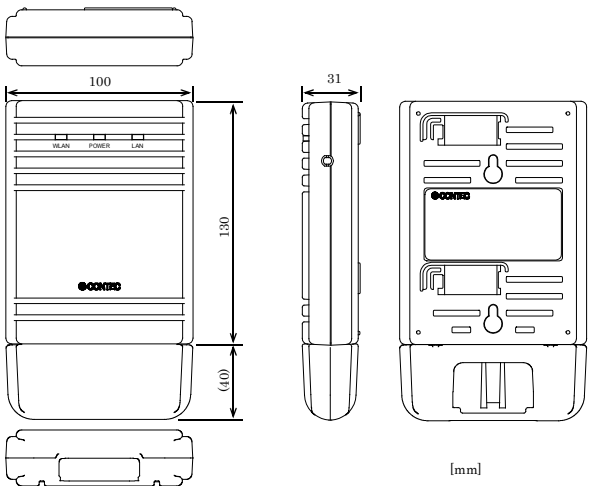

List of Option

- FX-AC053: AC Adapter (Output: +5VDC 3A)
- POA-201-10-2: AC Adapter (Output: +12VDC 1A)
- FX-BRA20: Wall/ceiling installation bracket
- POW-CB50AF: PoE Unit for supplying power from the LAN Connector
- POW-CB60AT: PoE power supply unit that supports Gigabit Ethernet

Component Name

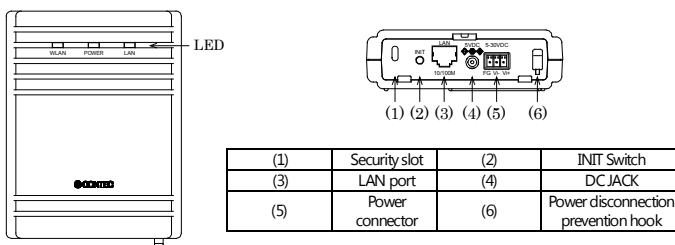

Power Supply

When using the AC adapter (FX-AC053)
 Pass the DC plug through the connector cover opening and connect the AC adapter's DC plug to the product's DC jack. You can prevent the DC plug from being pulled out by hooking the cord on the power disconnection prevention hook located on the connector section.

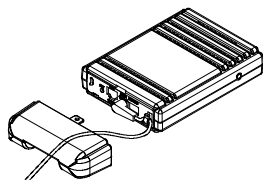

When supplying power from the power connector

Power can be externally supplied using the power connector. Use the components indicated to the followings for the power cable or use equivalent components.

| Function | | | |
|---|-------------|--------------------------------|---------|
| Power connector: MC1,5/3-ST-3,5(Phoenix CONTACT), Cable: AWG28-16(on the condition that the cable length satisfies the power specifications) | | | |
| Pin No. | Signal name | Meaning | 5-30VDC |
| 1 | Vi+ | Power supply (5 to 30 VDC ±5%) | |
| 2 | Vi- | Power supply (GND) | |
| 3 | FG | Frame ground | |

CAUTION

- Carefully manufacture the power cable taking care not to mistake the wiring. In particular, if the power cable is used with mistaken housing pin numbers, there is a risk of malfunction or accidents.
- Input voltage range: 5 to 30 VDC ± 5%. Use a power supply that rises to 4.75 VDC or higher in the input voltage range within 10 ms. There is a risk of damage to the device or accident if a power supply outside this range is used.

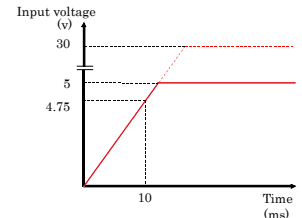

When supplying power from the LAN cable

The FXA3000 Series can be power-supplied through a LAN cable from an IEEE802.3af-compliant power supply unit. For details, refer to the power supply unit. The following gives an example of connection.

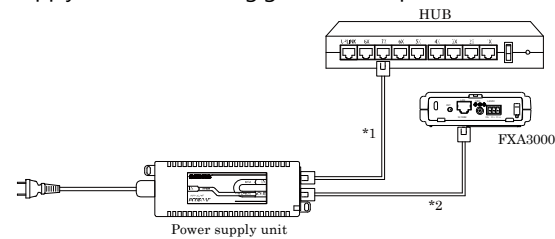

CAUTION

- The overall length of the LAN cable between the power supply destination and the hub must be up to 100 m. Route the cabling such that (1) + (2) is 100 (m) or less.
- Do not connect the output LAN cable to any IEEE802.3af non-compliant device as doing so can cause device faults or accidents.

Differences from FXA2000 Series

FXA3000 Series, the higher-grade model of the conventional FXA2000 Series, has the main differences as follows:

| | FXA3000 Series | FXA2000 Series |
|----------------------|---|---|
| Weight | 220g (Unit only), 250g (With connector cover attached) | 250g (Unit only), 270g (With connector cover attached) |
| Rating input current | 0.83A (5VDC input), 0.15A (30VDC input) (Max.), 0.13A (PoE input 48V) | 1.05A (5VDC input), 0.19A (30VDC input) (Max.), 0.15A (PoE input 48V) |

FXA3000 Series in use channel

FXA3000 number of channels that can be used in the Series are as follows.

| | | Access point / Repeater | Station |
|------------|----------------|---|---|
| FXA3000-US | 11b/g/n (2.4G) | 1ch, 2ch, 3ch, 4ch, 5ch, 6ch, 7ch, 8ch, 9ch, 10ch, 11ch | 1ch, 2ch, 3ch, 4ch, 5ch, 6ch, 7ch, 8ch, 9ch, 10ch, 11ch |
| | 11a/n (5G) | 36ch, 40ch, 44ch, 48ch, 149ch, 153ch, 157ch, 161ch, 165ch | 36ch, 40ch, 44ch, 48ch, 52ch, 56ch, 60ch, 64ch, 100ch, 104ch, 108ch, 112ch, 116ch, 132ch, 136ch, 140ch, 149ch, 153ch, 157ch, 161ch, 165ch |
| FXA3000-EU | 11b/g/n (2.4G) | 1ch, 2ch, 3ch, 4ch, 5ch, 6ch, 7ch, 8ch, 9ch, 10ch, 11ch, 12ch, 13ch | 1ch, 2ch, 3ch, 4ch, 5ch, 6ch, 7ch, 8ch, 9ch, 10ch, 11ch, 12ch, 13ch |
| | 11a/n (5G) | 36ch, 40ch, 44ch, 48ch, 52ch, 56ch, 60ch, 64ch, 100ch, 104ch, 108ch, 112ch, 116ch, 120ch, 124ch, 128ch, 132ch, 136ch, 140ch | 36ch, 40ch, 44ch, 48ch, 52ch, 56ch, 60ch, 64ch, 100ch, 104ch, 108ch, 112ch, 116ch, 120ch, 124ch, 128ch, 132ch, 136ch, 140ch |
| FXA3000-TW | 11b/g/n (2.4G) | 1ch, 2ch, 3ch, 4ch, 5ch, 6ch, 7ch, 8ch, 9ch, 10ch, 11ch | 1ch, 2ch, 3ch, 4ch, 5ch, 6ch, 7ch, 8ch, 9ch, 10ch, 11ch |
| | 11a/n (5G) | 56ch, 60ch, 64ch, 100ch, 104ch, 108ch, 112ch, 116ch, 132ch, 136ch, 140ch, 149ch, 153ch, 157ch, 161ch, 165ch | 56ch, 60ch, 64ch, 100ch, 104ch, 108ch, 112ch, 116ch, 132ch, 136ch, 140ch, 149ch, 153ch, 157ch, 161ch, 165ch |
| FXA3000-KR | 11b/g/n (2.4G) | 1ch, 2ch, 3ch, 4ch, 5ch, 6ch, 7ch, 8ch, 9ch, 10ch, 11ch, 12ch, 13ch | 1ch, 2ch, 3ch, 4ch, 5ch, 6ch, 7ch, 8ch, 9ch, 10ch, 11ch, 12ch, 13ch |
| | 11a/n (5G) | 36ch, 40ch, 44ch, 48ch, 52ch, 56ch, 60ch, 64ch, 100ch, 104ch, 108ch, 112ch, 116ch, 120ch, 124ch, 149ch, 153ch, 157ch, 161ch | 36ch, 40ch, 44ch, 48ch, 52ch, 56ch, 60ch, 64ch, 100ch, 104ch, 108ch, 112ch, 116ch, 120ch, 124ch, 149ch, 153ch, 157ch, 161ch |