

LM8327

*LM8327 Mobile I/O Companion Supporting Keyscan, I/O Expansion, PWM, and
ACCESS.bus Host Interface*



Literature Number: SNLS329

LM8327

Mobile I/O Companion Supporting Keyscan, I/O Expansion, PWM, and ACCESS.bus Host Interface

1.0 General Description

The LM8327 GenI/O-Expander and Keypad Controller is a dedicated device to unburden a host processor from scanning a matrix-addressed keypad and to provide flexible and general purpose, host-programmable input/output functions. Three independent PWM timer outputs are provided for dynamic LED brightness modulation.

It communicates with a host processor through an I²C-compatible ACCESS.bus serial interface. It can communicate in Standard (100 kHz) and Fast-Mode (400 kHz) in slave Mode only.

All available input/output pins can alternately be used as a direct key input connection, an input or an output in a keypad

matrix, or as a host-programmable general purpose input or output.

Any pin programmed as an input can also sense hardware interrupts. The interrupt polarity ("high-to-low" or "low-to-high" transition) is thereby programmable.

The LM8327 follows a predefined register based set of commands. Upon startup (power on) a configuration file must be sent from the host to setup the hardware of the device.

2.0 Applications:

- Cordless Phones
- Smart Handheld Devices
- Keyboard Applications

3.0 LM8327 Function Blocks

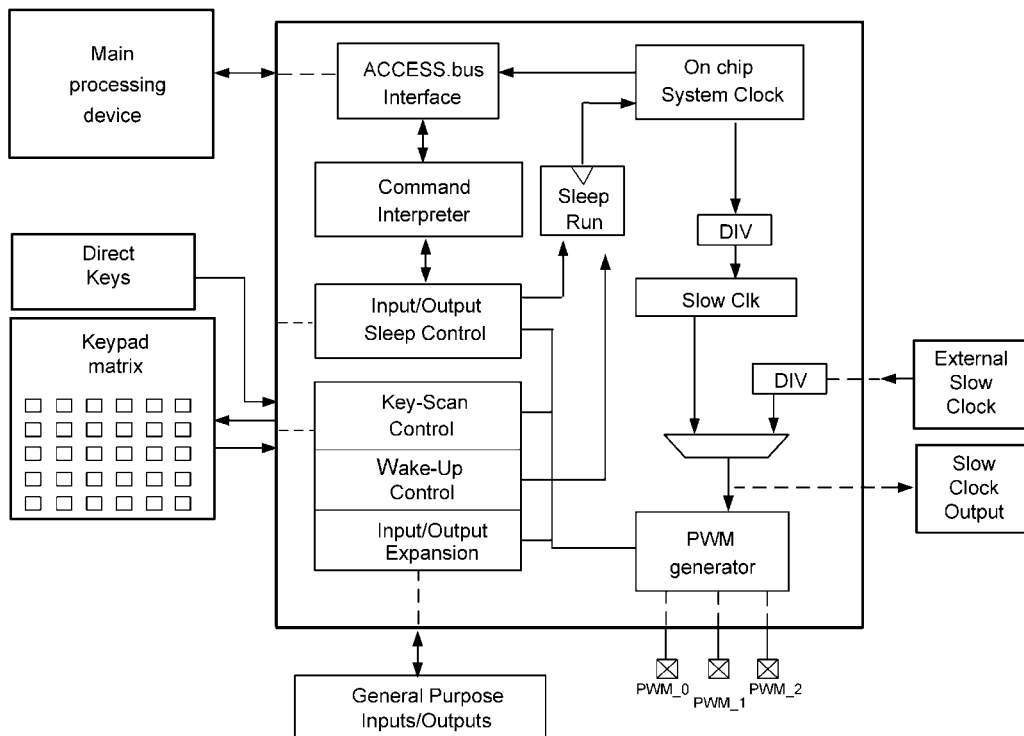

30124201

4.0 Features

4.1 KEY FEATURES

- Internal RC oscillator, no external clock required
- Internal PWM clock generation, no external clock required
- Programmable I²C-compatible ACCESS.bus address (Default 0x8A)
- Support for Keypad matrices of up to of 8 x 12 keys, plus 8 special function (SF) keys, for a full 104 key support
- Support for up to 26 direct connect keys
- I²C-compatible ACCESS.bus slave interface at 100 kHz (Standard-Mode) and 400 kHz (Fast-Mode)
- Three host-programmable PWM outputs for smooth LED brightness modulation
- Supports general-purpose I/O expansion on pins not otherwise used for keypad or PWM output
- 15-byte Key event buffer
- Multiple Key event storage
- Key events, errors, and dedicated hardware interrupts request host service by asserting an IRQ output
- Automatic HALT Mode for low power operation
- Wake-up from HALT mode on any interface (rising edge, falling edge or pulse)

- Three PWM outputs with dedicated script buffer for up to 32 commands
- Register-based command interpreter with auto-increment address

4.2 HOST-CONTROLLED FEATURES

- PWM scripting for three PWM outputs
- Period of inactivity that triggers entry into HALT mode
- Debounce time for reliable key event polling
- Configuration of general purpose I/O ports
- Various initialization options (keypad size, etc.)

4.3 KEY DEVICE FEATURES

- 1.8V ± 10% single-supply operation
- On-chip power-on reset (POR)
- ESD glitch filter on RESETN pin
- Watchdog timer
- Dedicated slow clock input for 32 kHz up to 8MHz
- -40°C to +85°C temperature range
- 36-pin MICRO ARRAY package

5.0 Pin Assignments

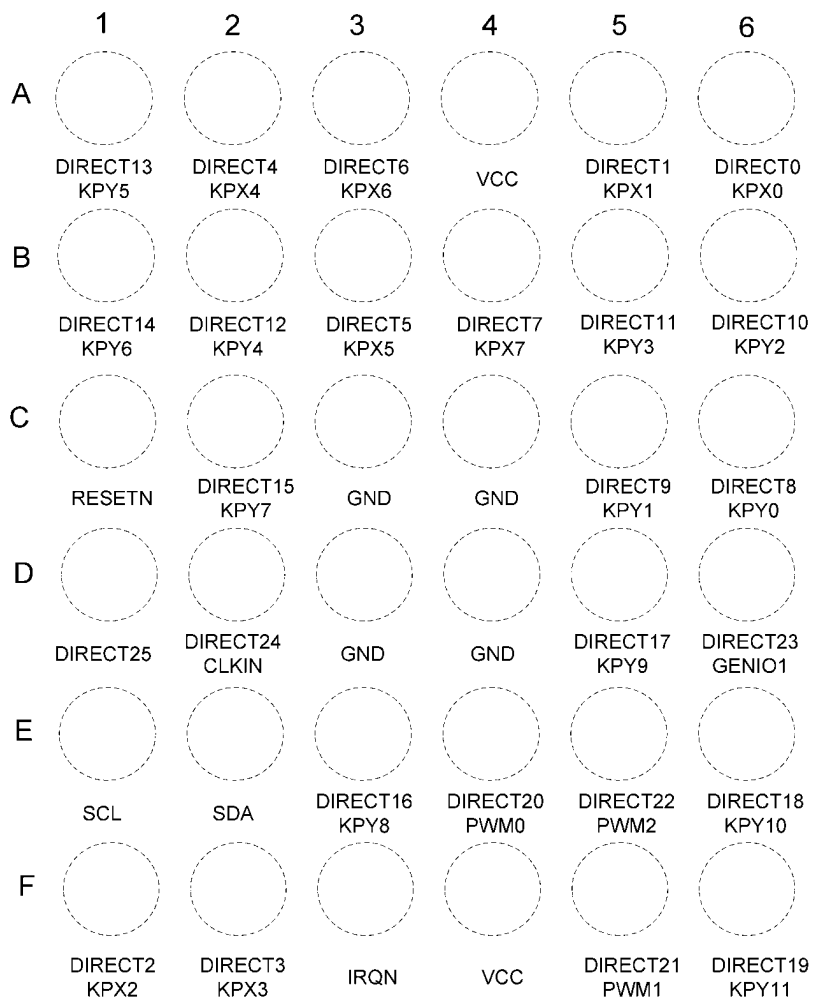

30124202

FIGURE 1. LM8327 Pinout - Top View

Table of Contents

1.0 General Description	1
2.0 Applications:	1
3.0 LM8327 Function Blocks	1
4.0 Features	2
4.1 KEY FEATURES	2
4.2 HOST-CONTROLLED FEATURES	2
4.3 KEY DEVICE FEATURES	2
5.0 Pin Assignments	3
6.0 Ordering Information	7
7.0 Signal Descriptions	7
7.1 DEVICE PIN FUNCTIONS	7
7.2 PIN CONFIGURATION AFTER RESET	9
8.0 Typical Application Setup	10
8.1 FEATURES	10
8.1.1 Hardware	10
8.1.2 Communication Layer	10
9.0 Halt Mode	11
9.1 HALT MODE DESCRIPTION	11
9.2 ACCESS.BUS ACTIVITY	11
10.0 LM8327 Programming Interface	12
10.1 ACCESS.BUS COMMUNICATION	12
10.1.1 Starting a Communication Cycle	12
10.1.2 Communication Initialized from Host (Restart from Sleep Mode)	13
10.1.3 ACCESS.Bus Communication Flow	13
10.1.4 Auto Increment	13
10.1.5 Reserved Registers and Bits	13
10.1.6 Global Call Reset	13
11.0 Keyscan Operation	15
11.1 KEYSKAN INITIALIZATION	15
11.2 KEYSKAN INITIALIZATION EXAMPLE	16
11.3 KEYSKAN PROCESS	17
11.4 READING KEYSKAN STATUS BY THE HOST	18
11.5 MULTIPLE KEY PRESSES	19
12.0 Direct Key Operation	20
12.1 DIRECT KEY INITIALIZATION	20
12.2 DIRECT KEY INITIALIZATION EXAMPLE	21
13.0 PWM Timer	22
13.1 OVERVIEW OF PWM FEATURES	22
13.2 OVERVIEW ON PWM SCRIPT COMMANDS	22
13.2.1 RAMP COMMAND	22
13.2.2 SET_PWM COMMAND	22
13.2.3 GO_TO_START COMMAND	23
13.2.4 BRANCH COMMAND	23
13.2.5 TRIGGER COMMAND	23
13.2.6 END COMMAND	23
14.0 LM8327 Register Set	25
14.1 KEYBOARD REGISTERS AND KEYBOARD CONTROL	25
14.1.1 KBDSETTLE - Keypad Settle Time Register	25
14.1.2 KBDBOUNCE - Debounce Time Register	25
14.1.3 KBDSIZE - Set Keypad Size Register	25
14.1.4 KBDEDCFG - Dedicated Key Register	26
14.1.5 KBDRIS - Keyboard Raw Interrupt Status Register	26
14.1.6 KBDMIS - Keypad Masked Interrupt Status Register	27
14.1.7 KBDIC - Keypad Interrupt Clear Register	27
14.1.8 KBDMASK - Keypad Interrupt Mask Register	28
14.1.9 KBDCODE0 - Keyboard Code Register 0	28
14.1.10 KBDCODE1 - Keyboard Code Register 1	28
14.1.11 KBDCODE2 - Keyboard Code Register 2	29
14.1.12 KBDCODE3 - Keyboard Code Register 3	29
14.1.13 EVTCODE - Key Event Code Register	29
14.2 PWM TIMER CONTROL REGISTERS	29
14.2.1 TIMCFGx - PWM Timer 0, 1 and 2 Configuration Registers	29
14.2.2 PWMCFGx - PWM Timer 0, 1 and 2 Configuration Control Registers	30
14.2.3 TIMSCALx - PWM Timer 0, 1 and 2 Prescale Registers	30

14.2.4	TIMSWRES - PWM Timer Software Reset Registers	31
14.2.5	TIMRIS - PWM Timer Interrupt Status Register	31
14.2.6	TIMMIS - PWM Timer Masked Interrupt Status Register	32
14.2.7	TIMIC - PWM Timer Interrupt Clear Register	33
14.2.8	PWMWP - PWM Timer Pattern Pointer Register	33
14.2.9	PWMCFG - PWM Script Register (Two Byte)	34
14.3	INTERFACE CONTROL REGISTERS	35
14.3.1	I2CSA - I ² C-Compatible ACCESS.bus Slave Address Register	35
14.3.2	MFGCODE - Manufacturer Code Register	35
14.3.3	SWREV - Software Revision Register	35
14.3.4	SWRESET - Software Reset	35
14.3.5	RSTCTRL - System Reset Register	35
14.3.6	RSTINTCLR - Clear NO Init/Power-On Interrupt Register	36
14.3.7	CLKMODE - Clock Mode Register	36
14.3.8	CLKCFG - Clock Configuration Register	37
14.3.9	CLKEN - Clock Enable Register	37
14.3.10	AUTOSLP - Autosleep Enable Register	37
14.3.11	AUTOSLPTI - Auto Sleep Time Register	38
14.3.12	IRQST - Global Interrupt Status Register	38
14.4	GPIO FEATURE CONFIGURATION	39
14.4.1	GPIO Feature Mapping	39
14.4.2	IOCGF - Input/Output Pin Mapping Configuration Register	39
14.4.3	IOPC0 - Pull Resistor Configuration Register 0	40
14.4.4	IOPC1 - Pull Resistor Configuration Register 1	40
14.4.5	IOPC2 - Pull Resistor Configuration Register 2	41
14.4.6	GPIOOME0 - GPIO Open Drain Mode Enable Register 0	42
14.4.7	GPIOOMS0 - GPIO Open Drain Mode Select Register 0	42
14.4.8	GPIOOME1 - GPIO Open Drain Mode Enable Register 1	43
14.4.9	GPIOOMS1 - GPIO Open Drain Mode Select Register 1	43
14.4.10	GPIOOME2 - GPIO Open Drain Mode Enable Register 2	43
14.4.11	GPIOOMS2 - GPIO Open Drain Mode Select Register 2	44
14.5	GPIO DATA INPUT/OUTPUT	44
14.5.1	GPIOPDATA0 - GPIO Data Register 0	44
14.5.2	GPIOPDATA1 - GPIO Data Register 1	45
14.5.3	GPIOPDATA2 - GPIO Data Register 2	46
14.5.4	GPIOPDIR0 - GPIO Port Direction Register 0	47
14.5.5	GPIOPDIR1 - GPIO Port Direction Register 1	47
14.5.6	GPIOPDIR2 - GPIO Port Direction Register 2	47
14.6	GPIO INTERRUPT CONTROL	48
14.6.1	GPIOIS0 - Interrupt Sense Configuration Register 0	48
14.6.2	GPIOIS1 - Interrupt Sense Configuration Register 1	48
14.6.3	GPIOIS2 - Interrupt Sense Configuration Register 2	48
14.6.4	GPIOIBE0 - GPIO Interrupt Edge Configuration Register 0	48
14.6.5	GPIOIBE1 - GPIO Interrupt Edge Configuration Register 1	49
14.6.6	GPIOIBE2 - GPIO Interrupt Edge Configuration Register 2	49
14.6.7	GPIOIEV0 - GPIO Interrupt Edge Select Register 0	49
14.6.8	GPIOIEV1 - GPIO Interrupt Edge Select Register 1	49
14.6.9	GPIOIEV2 - GPIO Interrupt Edge Select Register 2	50
14.6.10	GPIOIE0 - GPIO Interrupt Enable Register 0	50
14.6.11	GPIOIE1 - GPIO Interrupt Enable Register 1	50
14.6.12	GPIOIE2 - GPIO Interrupt Enable Register 2	50
14.6.13	GPIOIC0 - GPIO Clear Interrupt Register 0	51
14.6.14	GPIOIC1 - GPIO Clear Interrupt Register 1	51
14.6.15	GPIOIC2 - GPIO Clear Interrupt Register 2	51
14.7	GPIO INTERRUPT STATUS	52
14.7.1	GPORIS0 - Raw Interrupt Status Register 0	51
14.7.2	GPORIS1 - Raw Interrupt Status Register 1	52
14.7.3	GPORIS2 - Raw Interrupt Status Register 2	52
14.7.4	GPIOMIS0 - Masked Interrupt Status Register 0	52
14.7.5	GPIOMIS1 - Masked Interrupt Status Register 1	53
14.7.6	GPIOMIS2 - Masked Interrupt Status Register 2	53
14.8	GPIO WAKE-UP CONTROL	53
14.8.1	GPIOWAKE0 - GPIO Wake-Up Register 0	53
14.8.2	GPIOWAKE1 - GPIO Wake-Up Register 1	53
14.8.3	GPIOWAKE2 - GPIO Wake-Up Register 2	54
14.9	DIRECT KEY REGISTERS AND DIRECT KEY CONTROL	54

14.9.1	DEVTCODE - Direct Key Event Code Register	54
14.9.2	DBOUNCE - Direct Key Debounce Time Register	55
14.9.3	DIRECT0 - Direct Key Register 0	55
14.9.4	DIRECT1 - Direct Key Register 1	55
14.9.5	DIRECT2 - Direct Key Register 2	55
14.9.6	DIRECT3 - Direct Key Register 3	56
14.9.7	DKBDRIS - Direct Key Raw Interrupt Status Register	56
14.9.8	DKBDMIS - Direct Key Masked Interrupt Status Register	56
14.9.9	DKBDIC - Direct Key Interrupt Clear Register	57
14.9.10	DKBDMSK - Direct Key Interrupt Mask Register	57
15.0	Absolute Maximum Ratings	58
16.0	Electrical Characteristics	58
17.0	Registers	61
17.1	REGISTER MAPPING	61
17.1.1	Keyboard Registers	61
17.1.2	Direct Key Registers	61
17.1.3	PWM Timer Registers	62
17.1.4	System Registers	63
17.1.5	Global Interrupt Registers	63
17.1.6	GPIO Registers	63
18.0	Physical Dimensions	69

6.0 Ordering Information

NSID	Spec	Package Type	Package Method
LM8327JGR8	NOPB	MICRO ARRAY	1000 pieces tape & reel
LM8327JGR8X	NOPB	MICRO ARRAY	3500 pieces tape & reel

7.0 Signal Descriptions

7.1 DEVICE PIN FUNCTIONS

TABLE 1. KEY AND ALTERNATE FUNCTIONS OF ALL DEVICE PINS

Ball	Function 0	Function 1	Function 2	Function 3	Pin Count	Ball Name
D2	Direct Keypad24	Clock In		Genio	1	DIRECT24 CLKIN
D1	Direct Keypad25			Genio	1	DIRECT25
F3	Interrupt				1	IRQN
A4 F4	Supply Voltage				2	VCC
C1	ResetN				1	RESETN
E1	Main I ² C - Clk				1	SCL
E2	Main I ² C - Data				1	SDA
A6	Direct Keypad0	Keypad - I/O X0		Genio	1	DIRECT0 KPX0
A5	Direct Keypad1	Keypad - I/O X1		Genio	1	DIRECT1 KPX1
F1	Direct Keypad2	Keypad - I/O X2		Genio	1	DIRECT2 KPX2
F2	Direct Keypad3	Keypad - I/O X3		Genio	1	DIRECT3 KPX3
A2	Direct Keypad4	Keypad - I/O X4		Genio	1	DIRECT4 KPX4
B3	Direct Keypad5	Keypad - I/O X5		Genio	1	DIRECT5 KPX5
A3	Direct Keypad6	Keypad - I/O X6		Genio	1	DIRECT6 KPX6
B4	Direct Keypad7	Keypad - I/O X7		Genio	1	DIRECT7 KPX7
C6	Direct Keypad8	Keypad - I/O Y0		Genio	1	DIRECT8 KPY0
C5	Direct Keypad9	Keypad - I/O Y1		Genio	1	DIRECT9 KPY1
B6	Direct Keypad10	Keypad - I/O Y2		Genio	1	DIRECT10 KPY2
B5	Direct Keypad11	Keypad - I/O Y3		Genio	1	DIRECT11 KPY3
B2	Direct Keypad12	Keypad - I/O Y4		Genio	1	DIRECT12 KPY4
A1	Direct Keypad13	Keypad - I/O Y5		Genio	1	DIRECT13 KPY5
B1	Direct Keypad14	Keypad - I/O Y6		Genio	1	DIRECT14 KPY6
C2	Direct Keypad15	Keypad - I/O Y7		Genio	1	DIRECT15 KPY7

Ball	Function 0	Function 1	Function 2	Function 3	Pin Count	Ball Name
E3	Direct Keypad16	Keypad - I/O Y8		Genio	1	DIRECT16 KPY8
D5	Direct Keypad17	Keypad - I/O Y9		Genio	1	DIRECT17 KPY9
E6	Direct Keypad18	Keypad - I/O Y10		Genio	1	DIRECT18 KPY10
F6	Direct Keypad19	Keypad - I/O Y11	Clockout	Genio	1	DIRECT19 KPY11
E4	Direct Keypad20	PWM output 0		Genio	1	DIRECT20 PWM0
F5	Direct Keypad21	PWM output 1		Genio	1	DIRECT21 PWM1
E5	Direct Keypad22	PWM output 2		Genio	1	DIRECT22 PWM2
D6	Direct Keypad23			Genio	1	DIRECT23 GENIO1
C3 C4 D3 D4	Ground				4	GND
	TOTAL				36	

7.2 PIN CONFIGURATION AFTER RESET

Upon power-up or RESET the LM8327 will have defined states on all pins. [Table 2](#) provides a comprehensive overview on the states of all functional pins.

TABLE 2. Pin Configuration after Reset

Pins	Pin States
DIRECT KEYPAD 0 DIRECT KEYPAD 1 DIRECT KEYPAD 2 DIRECT KEYPAD 3 DIRECT KEYPAD 4 DIRECT KEYPAD 5 DIRECT KEYPAD 6 DIRECT KEYPAD 7 DIRECT KEYPAD 8 DIRECT KEYPAD 9 DIRECT KEYPAD 10 DIRECT KEYPAD 11 DIRECT KEYPAD 12 DIRECT KEYPAD 13 DIRECT KEYPAD 14 DIRECT KEYPAD 15 DIRECT KEYPAD 16 DIRECT KEYPAD 17 DIRECT KEYPAD 18 DIRECT KEYPAD 19 DIRECT KEYPAD 20 DIRECT KEYPAD 21 DIRECT KEYPAD 22 DIRECT KEYPAD 23 DIRECT KEYPAD 24 DIRECT KEYPAD 25	Full Buffer mode input with an on-chip pull-up resistor enabled.
IRQN	Open Drain mode with no pull resistor enabled, driven low. <i>NOTE: The IRQN is driven low after Power-On Reset due to PORIRQ signal. The value 0x01 must be written to the RSTINTCLR register (0x84) to release the IRQN pin.</i>
SCL SDA	Open Drain mode with no pull resistor enabled.

8.0 Typical Application Setup

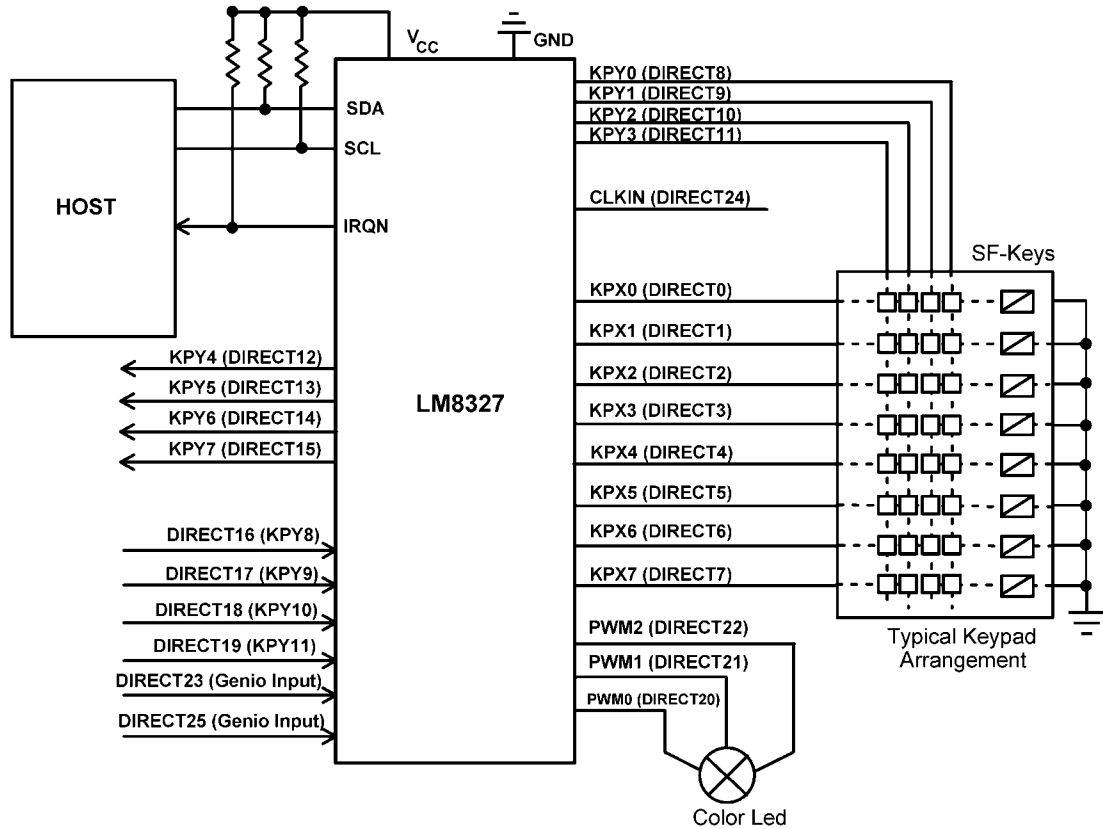

30124203

FIGURE 2. LM8327 in a Typical Setup with Standard Handset Keypad

8.1 FEATURES

The following features are supported with the application example shown above:

8.1.1 Hardware

Hardware

- 4 x 8 keys and 8 Special Function (SF) keys for 40 keys.
- ACCESS.bus interface for communication with a host device.
 - communication speeds supported are: 100 kHz standard mode and 400 kHz fast mode of operation.
- Interrupt signal (IRQN) to indicate any keypad or hardware interrupt events to the host.
- Sophisticated PWM function block with 3 independent channels to control color LED.

- External clock input for accurate PWM clock (not used).
- Four host-programmable dedicated general-purpose output pins (GPIOs:KPY4:7) supporting I/O-expansion capabilities for host device.
- Six host-programmable dedicated direct key connection input pins (DIRECT 16:19, 23, 25) with wake-up supporting I/O-expansion capabilities for host device.

8.1.2 Communication Layer

- Versatile register-based command integration supported from on-chip command interpreter.
- Keypad event storage.
- Individual PWM script file storage and execution control for 3 PWM channels.

9.0 Halt Mode

9.1 HALT MODE DESCRIPTION

The fully static architecture of the LM8327 allows stopping the internal RC clock in Halt mode, which reduces power consumption to the minimum level. [Figure 3](#) shows an estimate of the current in Halt mode at the maximum VCC (1.98V) from 25°C to +85°C.

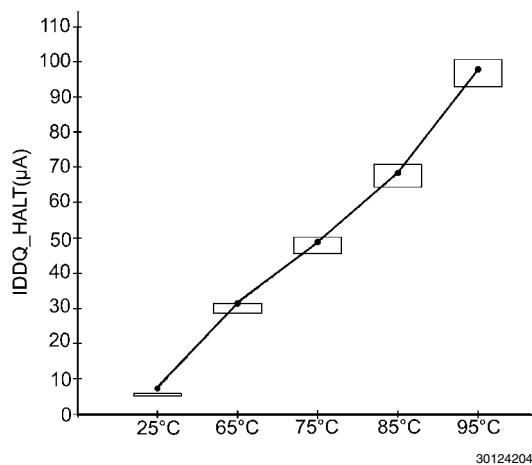

FIGURE 3. Halt Current vs. Temperature at 1.98V

Halt mode is entered when no key-press event, key-release event, or is detected for a certain period of time (by default, 1020 milliseconds). The mechanism for entering Halt mode is always enabled in hardware, but the host can program the period of inactivity which triggers entry into Halt mode using the autosleep function. (See [Table 52](#).)

9.2 ACCESS.BUS ACTIVITY

When the LM8327 is in Halt mode, only activity on the ACCESS.bus interface that matches the LM8327 Slave Address will cause the LM8327 to exit from Halt mode. However, the LM8327 will not be able to acknowledge the first bus cycle immediately following wake-up from Halt mode. It will respond with a negative acknowledgement, and the host should then repeat the cycle. A peripheral that is continuously active can share the bus since this activity will not prevent the LM8327 from entering Halt mode.

10.0 LM8327 Programming Interface

The LM8327 operation is controlled from a host device by a complete register set, accessed via the I²C-compatible ACCESS.bus interface. The ACCESS.bus communication is based on a READ/WRITE structure, following the I²C trans-

mission protocol. All functions can be controlled by configuring one or multiple registers. Please refer to [Section 14.0 LM8327 Register Set](#) for the complete register set.

10.1 ACCESS.BUS COMMUNICATION

[Figure 4](#) shows a typical read cycle initiated by the host.

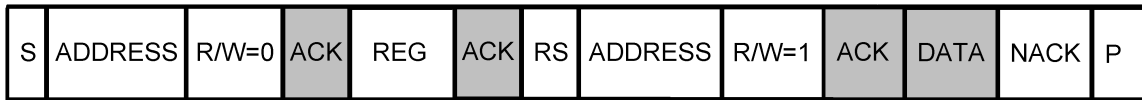

30124205

FIGURE 4. Master/Slave Serial Communication (Host to LM8327)

TABLE 3. Definition of Terms used in Serial Command Example

Term	Bits	Description
S		START Condition (always generated from the master device)
ADDRESS	7	Slave address of LM8327 sent from the host
R/W	1	This bit determines if the following data transfer is from master to slave (data write) or from slave to master (data read). 0: Write 1: Read
ACK	1	An acknowledge bit is mandatory and must be appended on each byte transfer. The Acknowledge status is actually provided from the slave and indicates to the master that the byte transfer was successful.
REG	8	The first byte after sending the slave address is the REGISTER byte which contains the physical address the host wants to read from or write to.
RS		Repeated START condition
DATA	8	The DATA field contains information to be stored into a register or information read from a register.
NACK	1	Not Acknowledge Bit. The Not Acknowledge status is assigned from the Master receiving data from a slave. The NACK status will actually be assigned from the master in order to signal the end of a communication cycle transfer
P		STOP condition (always generated from the master device).

All actions associated with the non-shaded boxes in [Figure 4](#) are controlled from the master (host) device.

All actions associated with the shaded boxes in [Figure 4](#) are controlled from the slave (LM8327) device.

The master device can send subsequent REGISTER addresses separated by Repeated START conditions. A STOP condition must be set from the master at the very end of a communication cycle.

It is recommended to use Repeated START conditions in multi-Master systems when sending subsequent REGISTER addresses. This technique will make sure that the master device communicating with the LM8327 will not lose bus arbitration.

10.1.1 Starting a Communication Cycle

There are two reasons for the host device to start communication to the LM8327:

1. The LM8327 device has set the IRQN line low in order to signal a key - event or any other condition which initializes a hardware interrupt from LM8327 to the host.

2. The host device wants to set a GENIO port, read from a GENIO port, configure a GENIO port, and read the status from a register or initialize any other function which is supported from the LM8327. In case a GENIO shall be read it will be most likely, that the LM8327 device will be residing in "sleep mode". In this mode the system clock will be off to establish the lowest possible current consumption. If the host device starts the communication under this condition the LM8327 device will not be able to acknowledge the first attempt of sending the slave address. The LM8327 will wake up because of the START condition but it can't establish the internal timing to scan the first byte received. The master device must therefore apply a second attempt to start the communication with the LM8327 device.

10.1.2 Communication Initialized from Host (Restart from Sleep Mode)

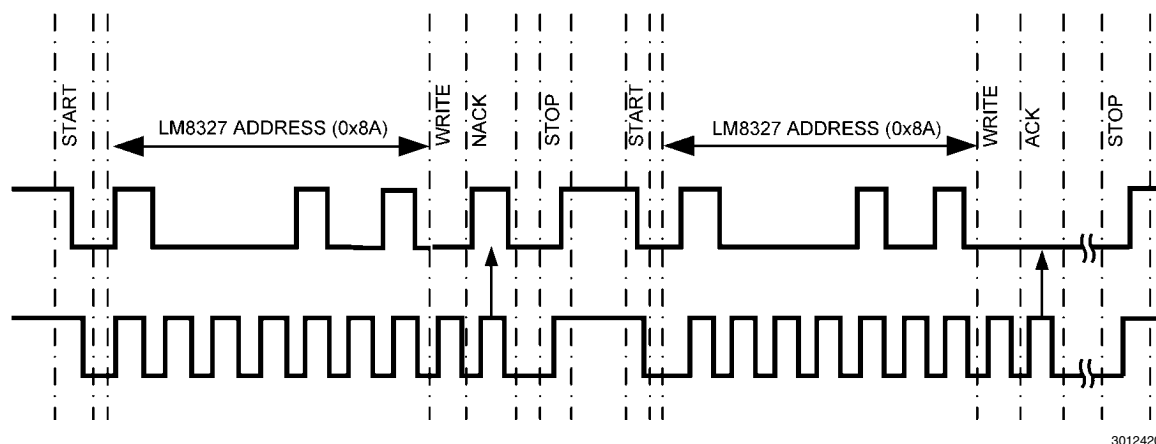

FIGURE 5. Host Starts Communication While LM8327 is in Sleep Mode

- In the timing diagram shown in [Figure 5](#) the LM8327 resides in sleep mode. Since the LM8327 device can't acknowledge the slave address the host must generate a STOP condition followed by a second START condition.
- On the second attempt the slave address is being acknowledged from the LM8327 device because it is in active mode now.
- The host can send different WRITE and/or READ commands subsequently after each other.
- The host must finally free the bus by generating a STOP condition.

10.1.3 ACCESS.Bus Communication Flow

The LM8327 will only be driven in slave mode. The maximum communication speed supported is Fast Mode (FS) which is 400 kHz. The device can be heavily loaded as it is processing different kind of events caused from the human interface and the host device. In such cases the LM8327 may temporarily be unable to accept new commands and data sent from the host device.

Please Note: "It is a legitimate measure of the slave device to hold SCL line low in such cases in order to force the master device into a waiting state!. It is therefore the obligation of the host device to detect such cases. Typically there is a control bit set in the master device indicating the Busy status of the bus. As soon as the SCL line is released the host can continue sending commands and data."

Further Remarks:

- In systems with multiple masters it is recommended to separate commands with Repeat START conditions rather than sending a STOP - and another START - condition to communicate with the LM8327 device.
- Delays enforced by the LM8327 during very busy phases of operation should typically not exceed a duration of 100 μ sec.

- Normally the LM8327 will clock stretch after the acknowledge bit is transmitted; however, there are some conditions where the LM8327 will clock stretch between the SDA Start bit and the first rising edge of SCL.

10.1.4 Auto Increment

In order to improve multi-byte register access, the LM8327 supports the auto increment of the address pointer.

A typical protocol access sequence to the LM8327 starts with the I²C-compatible ACCESS.bus address, followed by REG, the register to access (see [Figure 4](#)). After a REPEATED START condition the host reads/writes a data byte from/to this address location. If more than one byte is transmitted, the LM8327 automatically increments the address pointer for each data byte by 1. The address pointer keeps the status until the STOP condition is received.

The LM8327 always uses auto increments unless otherwise noted.

Please refer to [Table 4](#) and [Table 5](#) for the typical ACCESS.bus flow of reading and writing multiple data bytes.

10.1.5 Reserved Registers and Bits

The LM8327 includes reserved registers for future implementation options. Please use value 0 on a write to all reserved register bits.

10.1.6 Global Call Reset

The LM8327 supports the Global Call Reset as defined in the I²C Specification, which can be used by the host to reset all devices connected to interface. The Global call reset is a single byte ACCESS.bus/I²C write of data byte 0x06 to slave address 0x00.

The Global Call Reset changes the I²C-compatible ACCESS.bus Slave address of the LM8327 back to its default value of 0x8A.

TABLE 4. Multi-Byte Write with Auto Increment

Step	Master/Slave	I ² C Com.	Value	Address Pointer	Comment
1	M	S			START condition
2	M	ADDR.	0x8A		I ² C-compatible ACCESS.bus Address
3	M	R/W	0		Write
4	S	ACK			Acknowledge
5	M	REG	0xAA	0xAA	Register Address, used as Address Pointer
6	S	ACK		0xAA	Acknowledge
7	M	DATA	0x01	0xAA	Write Data to Address in Pointer
8	S	ACK	0	0xAB	Acknowledge, Address pointer incremented
9	M	DATA	0x05	0xAB	Write Data to address 0xAB
10	S	ACK	0	0xAC	Acknowledge, Address pointer incremented
11	M	P			STOP condition

TABLE 5. Multi-Byte Read with Auto Increment

Step	Master/Slave	I ² C Com.	Value	Address Pointer	Comment
1	M	S			START condition
2	M	ADDR.	0x8A		I ² C-compatible ACCESS.bus Address
3	M	R/W	0		Write
4	S	ACK			Acknowledge
5	M	REG	0xAA	0xAA	Register Address, used as Address pointer
6	S	ACK		0xAA	Acknowledge
7	M	RS		0xAA	Repeated Start
8	M	ADDR.	0x8A	0xAA	I ² C-compatible ACCESS.bus Address
9	M	R/W	1		Read
10	S	ACK	0	0xAA	Acknowledge
11	S	DATA	0x01	0xAA	Read Data from Address in Pointer
12	M	ACK	0	0xAB	Acknowledge, Address Pointer incremented
13	S	DATA	0x05	0xAB	Read Data from Address in Pointer
14	M	NACK	0	0xAC	No Acknowledge, stops transmission
15	M	P			STOP condition

All non-bolded actions rows in Tables 4 and 5 are controlled from the master (host) device.
 All **highlighted** rows in Tables 4 and 5 are controlled from the slave (LM8327) device.

11.0 Keyscan Operation

11.1 KEYSKAN INITIALIZATION

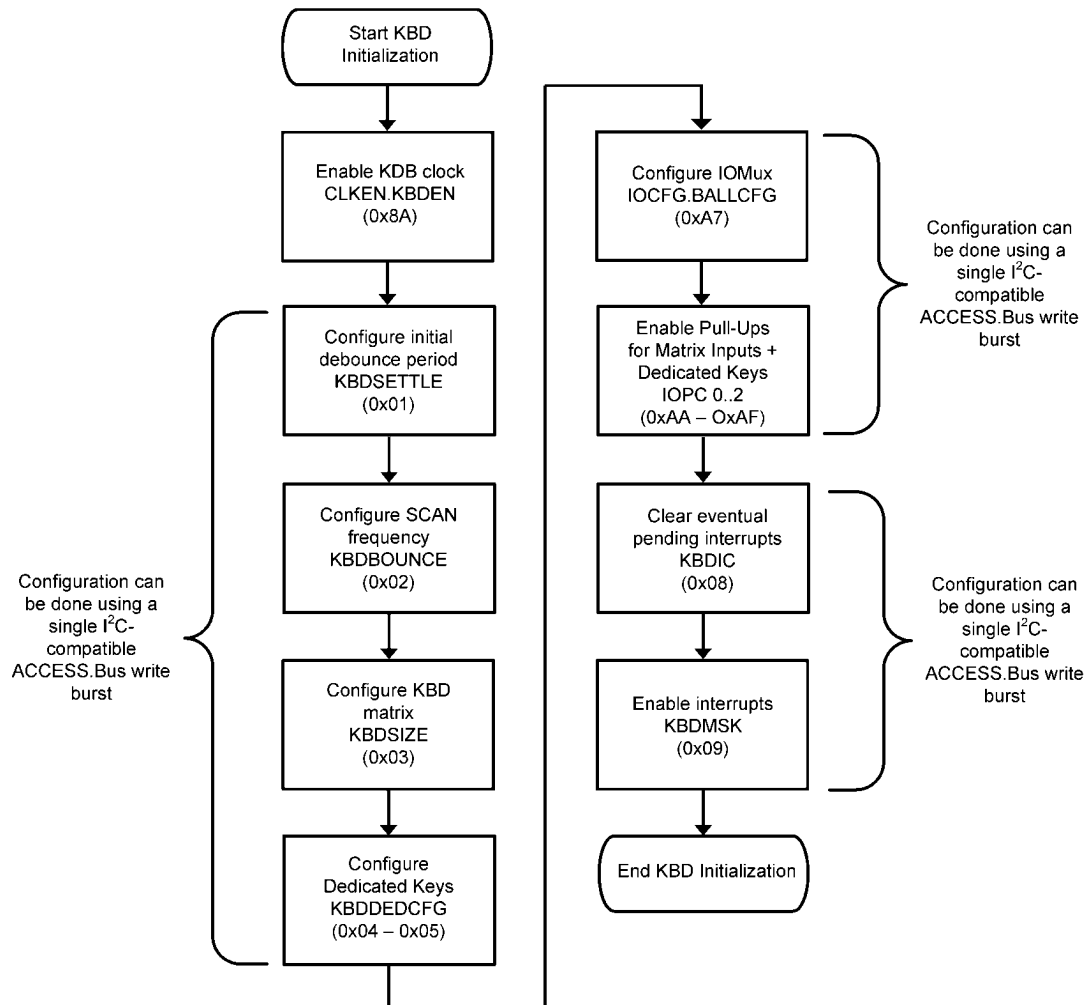

30124207

FIGURE 6. Keyscan Initialization

11.2 KEYSKAN INITIALIZATION EXAMPLE

- Keypad matrix configuration is 8 rows x 12 columns.

Table 6 shows all the LM8327 register configurations to initialize keyscan:

TABLE 6. Keyscan Initialization Example

Register name	Adress	Access Type	Value	Comment
CLKEN	0x8A	byte	0x01	enable keyscan clock
KBDSETTLE	0x01	byte	0x80	set the keyscan settle time to 12 msec
KBDBOUNCE	0x02	byte	0x80	set the keyscan debounce time to 12 msec
KBDSIZE	0x03	byte	0x8C	set the keyscan matrix size to 8 rows x 12 columns
KBDDEDCFG	0x04	word	0xFFFF	configure KPX[7:2] and KPY[11:2] pins as keyboard matrix
IOCFG	0xA7	byte	0x00	write default value to enable all pins as keyboard matrix
IOPC0	0xAA	word	0xAAAA	configure pull-up resistors for KPX[7:0]
IOPC1	0xAC	word	0x5555	configure pull-down resistors for KPY[7:0]
IOPC2	0xAE	word	0x0055	configure pull-down resistors for KPY[11:8]
KBDIC	0x08	byte	0x03	clear any pending interrupts
KBDMSK	0x09	byte	0x03	enable keyboard interrupts

11.3 KEYSKAN PROCESS

The LM8327 keyscan functionality is based on a specific scanning procedure performed in a 4ms interval. On each scan all assigned key matrix pins are evaluated for state changes.

In case a key event has been identified, the event is stored in the key event FIFO, accessible via the EVTCODE register. A key event can either be a key press or a key release. In addition, key presses are also stored in the KBDCODE[3:0] registers. As soon as the EVTCODE FIFO includes an event,

the device sets the RAW keyboard event interrupt REVTINT. The RSINT interrupt is set anytime the keyboard status has changed.

Depending on the interrupt masking for the keyboard events (KBDMSK) and the masked interrupt handling (KBDMIS), the pin IRQN will follow the IRQST.KBDIRQ status, which is set as soon as one interrupt in KBDRIS is set.

Figure 7 shows the basic flow of a scanning process and which registers are affected.

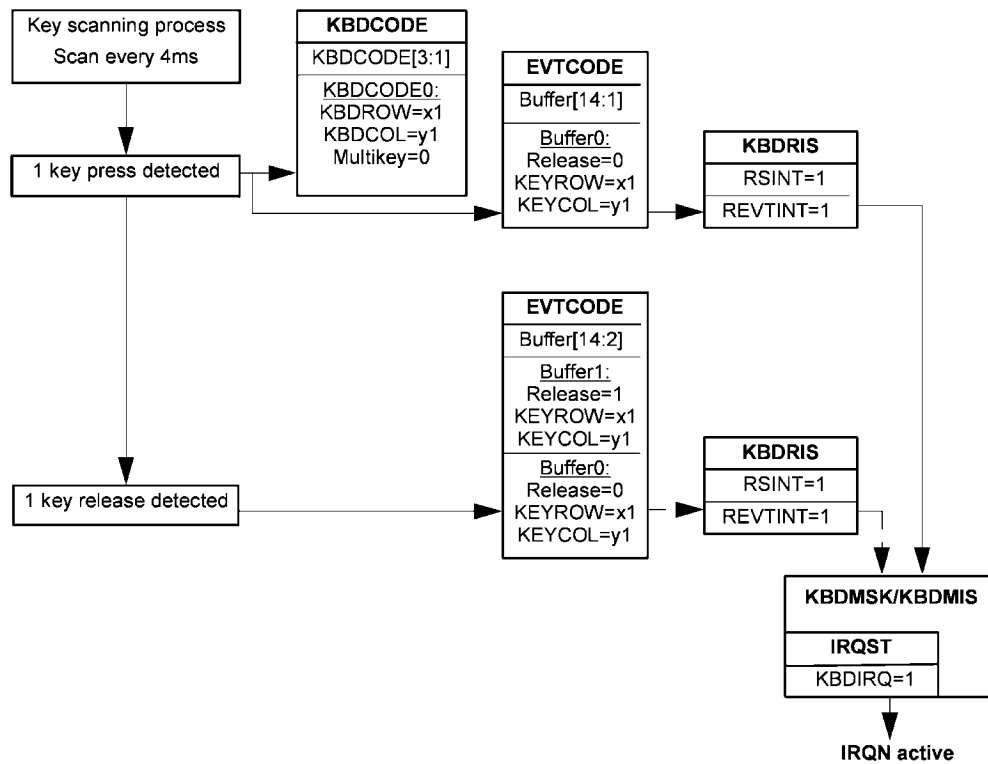

30124208

FIGURE 7. Example Keyscan Operation for 1 Key Press and Release

11.4 READING KEYSKAN STATUS BY THE HOST

In order to keep track of the keyscan status, the host either needs to regularly poll the EVTCODE register or needs to react on the Interrupt signaled by the IRQN pin.

Figure 8 gives an example on which registers to read to get the keyboard events from the LM8327 and how they influence the interrupt event registers. The example is based on the assumption that the LM8327 has indicated the keyboard event by the IRQN pin.

Since the interrupt pin has various sources, the host first checks the IRQST register for the interrupt source. If KBDIRQ is set, the host can check the KBDMIS register to define the exact interrupt source. KBDMIS contains the masked status of KBDRIS and reflects the source for raising the interrupt pin. The interrupt mask is defined by KBDMSK. The complete status of all pending keyboard interrupts is available in the raw interrupt register KBDRIS.

After evaluating the interrupt source the host starts reading the EVTCODE or KBDCODE register. In this example the

host first reads the KBDCODE to get possible key press events and afterwards reads the complete event list by reading the EVTCODE register until all events are captured (0x7F indicates end of buffer).

Reading KBDCODE clears the RSINT interrupt bit if all keyboards events are emptied. In the same way, REVTINT is cleared in case the EVTCODE FIFO reaches its empty state on read.

The event buffer content and the REVTINT and RELINT (lost event) interrupt bits are also cleared if the KBDIC.EVTIC bit is set.

Interrupt bits in the masked interrupt register KBDMIS follow the masked KBDRIS status.

In order to support efficient Multi-byte reads from EVTCODE, the autoincrement feature is turned off for this register. Therefore the host can continuously read the complete EVTCODE buffer by sending one command.

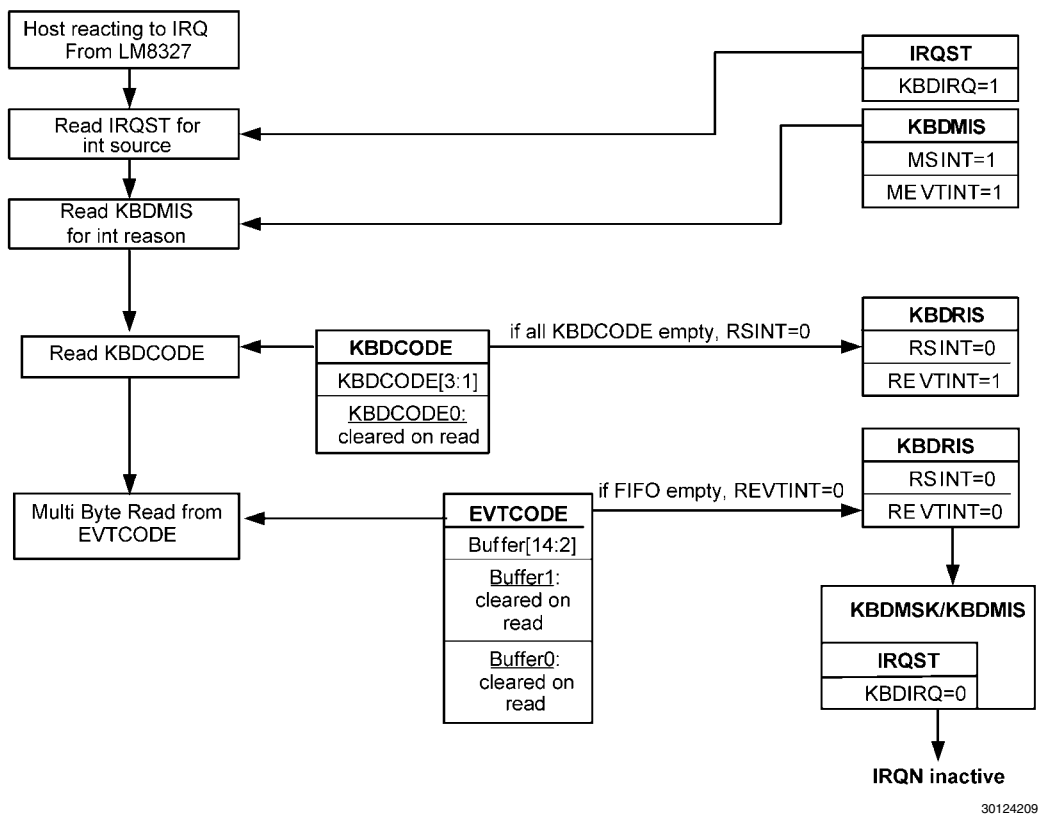

FIGURE 8. Example Host Reacting to Interrupt for Keypad Event

30124209

11.5 MULTIPLE KEY PRESSES

The LM8327 supports up to four simultaneous key presses. Any time a single key is pressed KBDCODE0 is set with the appropriate key code. If a second key is pressed, the key is stored in KBDCODE1 and the MULTIKEY flag of KBDCODE0 is set. Additional key presses are stored in KBDCODE2 and

KBDCODE3 accordingly. The four registers signal the last multi-key press events.

All events are stored in parallel in the EVTCODE register for the complete set of events.

All KBDCODE[3:0] registers are cleared on read.

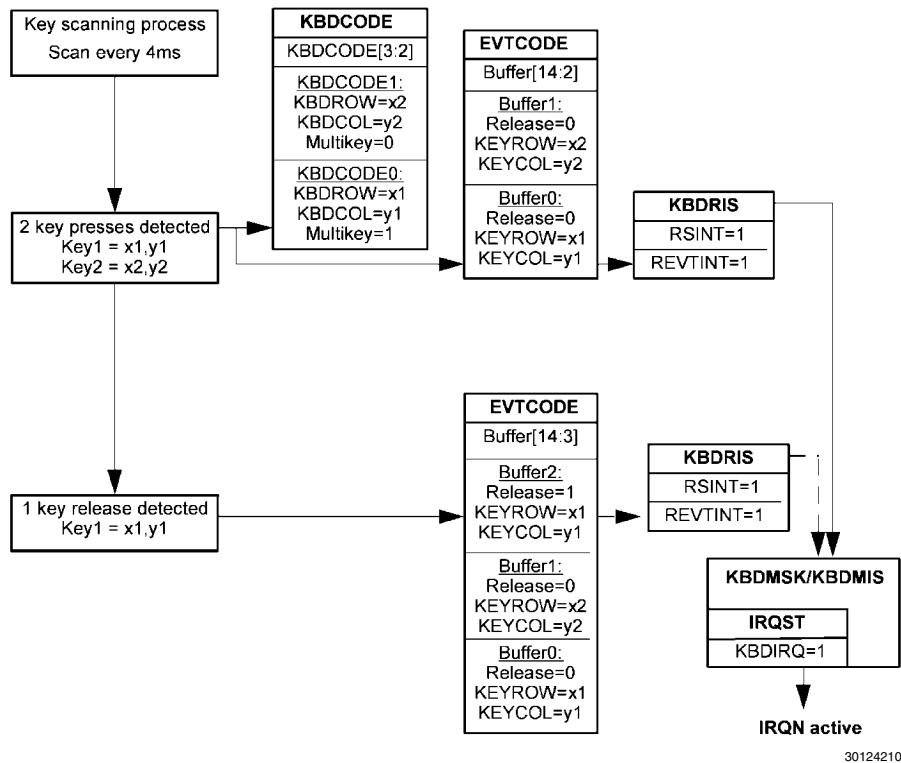
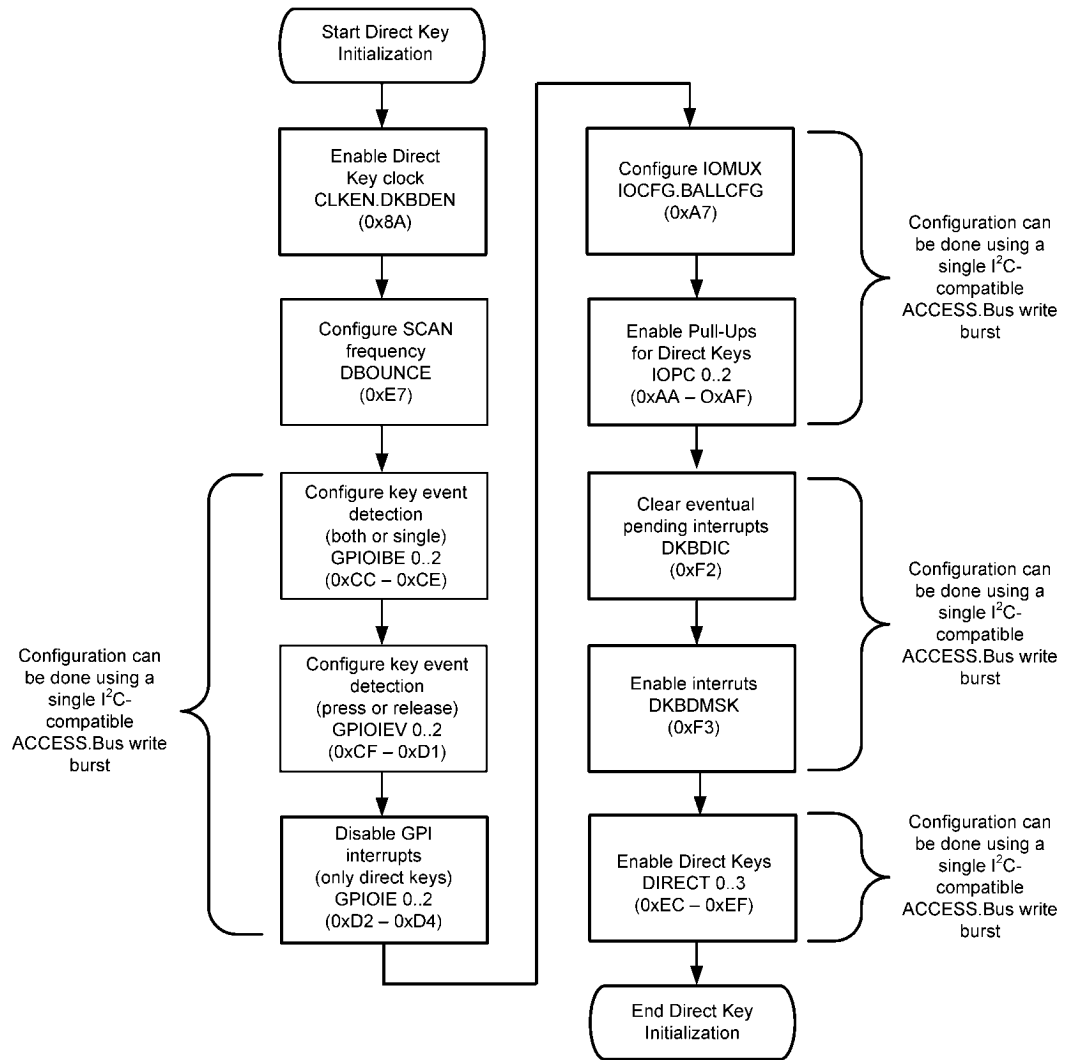

FIGURE 9. Example Keyscan Operation for 2 Key Press Events and 1 Key Release Event

12.0 Direct Key Operation

12.1 DIRECT KEY INITIALIZATION



30124213

FIGURE 10. Direct Key Initialization

12.2 DIRECT KEY INITIALIZATION EXAMPLE

Table 7 shows all the LM8327 register configurations to initialize direct keys.

- Direct key configuration is for 26 direct keys.

TABLE 7. Direct Key Initialization Example

Register Name	Address	Access Type	Value	Comment
CLKEN	0x8A	byte	0x02	Enable direct key clock
DBOUNCE	0xE7	byte	0x04	Set the keyscan debounce time to 12 msec.
GPIOIBE0	0xCC	byte	0x00	Configure single key event detection for DK[7:0]
GPIOIBE1	0xCD	byte	0x00	Configure single key event detection for DK[15:8]
GPIOIBE2	0xCE	byte	0x00	Configure single key event detection for DK[23:16]
GPIOIEV0	0xCF	byte	0x00	Configure press key event detection DK[7:0]
GPIOIEV1	0xD0	byte	0x00	Configure press key event detection DK[15:8]
GPIOIEV2	0xD1	byte	0x00	Configure press key event detection DK[23:16]
GPIOIE0	0xD2	byte	0x00	Disable GPI interrupts for DK[7:0]
GPIOIE1	0xD3	byte	0x00	Disable GPI interrupts for DK[15:8]
GPIOIE2	0xD4	byte	0x00	Disable GPI interrupts for DK[23:16]
IOCFG	0xA7	byte	0x00	Write default value to enable all pins as direct keys
IOPC0	0xAA	word	0xAAAA	Configure pull-up resistors for DK[7:0]
IOPC1	0xAC	word	0xAAAA	Configure pull-up resistors for DK[15:8]
IOPC2	0xAE	word	0xAAAA	Configure pull-up resistors for DK[23:16]
DKBDIC	0xF2	byte	0x01	Clear any pending interrupts
DKBDMSK	0xF3	byte	0x00	Enable direct key and lost direct key interrupts
DIRECT0	0xEC	byte	0xFF	Enable pins as DK[7:0]
DIRECT1	0xED	byte	0xFF	Enable pins as DK[15:8]
DIRECT2	0xEE	byte	0xFF	Enable pins as DK[23:16]
DIRECT3	0xEF	byte	0x03	Enable pins as DK[25:24]

13.0 PWM Timer

The LM8327 supports a timer module dedicated to smooth LED control techniques (lighting controls).

The PWM timer module consists of three independent timer units of which each can generate a PWM output with a fixed period and automatically incrementing or decrementing variable duty cycle. The timer units are all clocked with a slow (32.768 kHz) clock whereas the interface operates with the main system clock.

13.1 OVERVIEW OF PWM FEATURES

- Each PWM can establish fixed - or variable - duty-cycle signal sequences on its output.
- Each PWM can trigger execution of any pre-programmed task on another PWM channel.

- The execution of any pre-programmed task is self-sustaining and does not require further interaction from the host.
- 64-byte script buffer for each PWM for up to 32 consecutive instructions.
- Direct addressing within script buffer to support multiple PWM tasks in one buffer.

13.2 OVERVIEW ON PWM SCRIPT COMMANDS

The commands listed in [Table 8](#) are dedicated to the slow PWM timers.

Please note: The PWM Script commands are not part of the command set supported by the LM8327 command interpreter. These commands must be transferred from the host with help of the register-based command set.

TABLE 8. PWM Script Commands

Command	15	14	13	12	11	10	9	8	7	6	5	4	3	2	1	0
RAMP	0	PRESCALE	STEPTIME				SIGN		INCREMENT							
SET_PWM	0	1	0				PWMVALUE									
GO_TO_START	0															
BRANCH	1	0	1	LOOPCOUNT				ADDR	STEPNUMBER							
END	1	1	0	1	INT	X										
TRIGGER	1	1	1	WAITTRIGGER				SENDTRIGGER								0

13.2.1 RAMP COMMAND

A RAMP command will vary the duty cycle of a PWM output in either direction (up or down). The INCREMENT field specifies the amount of steps for the RAMP. The maximum amount of steps which can be executed with one RAMP Command is 126 which is equivalent to 50%. The SIGN bit field determines

the direction of a RAMP (up or down). The STEPTIME field and the PRESCALE bit determine the duration of one step. Based on a 32.768 kHz clock, the minimum time resulting from these options would be 0.49 milliseconds and the maximum time for one step would be 1 second.

TABLE 9. RAMP Command Bit Fields

15	14	13	12	11	10	9	8	7	6	5	4	3	2	1	0
0	PRESCALE	STEPTIME				SIGN		INCREMENT							

TABLE 10. Description of Command Bit Fields of the RAMP Command

Bit or Field	Value	Description
PRESCALE	0	Divide the 32.768 kHz clock by 16
	1	Divide the 32.768 kHz clock by 512
STEPTIME	1 - 63	Number of prescaled clock cycles per step
SIGN	0	Increment RAMP counter
	1	Decrement RAMP counter
INCREMENT	0 - 126	Number of steps executed by this instruction; a value of 0 functions as a WAIT determined by STEPTIME.

13.2.2 SET_PWM COMMAND

The SET_PWM command does not allow generation of a PWM output with a fixed duty cycle between 0% and 100%. This command will set the starting duty cycle MIN SCALE or

FULL SCALE (0% or 100%). A RAMP command following the SET_PWM command will finally establish the desired duty cycle on the PWM output.

TABLE 11. SET_PWM Command Bit Fields

15	14	13	12	11	10	9	8	7	6	5	4	3	2	1	0
0	1	0	0	0	0	0	0	DUTYCYCLE							

TABLE 12. Description of Bit Fields of the SET_PWM Command

Bit or Field	Value	Description
DUTYCYCLE	0	Duty cycle is 0%.
	255	Duty cycle is 100%.

13.2.3 GO_TO_START COMMAND

The GO_TO_START command jumps to the first command in the script command file.

TABLE 13. GO_TO_START Command Bit Fields

15	14	13	12	11	10	9	8	7	6	5	4	3	2	1	0
0															

13.2.4 BRANCH COMMAND

The BRANCH command jumps to the specified command in the script command file. The BRANCH is executed with either absolute or relative addressing. In addition, the command

gives the option of looping for a specified number of repetitions.

Please note: Nested loops are not allowed.

TABLE 14. BRANCH Command Bit Fields

15	14	13	12	11	10	9	8	7	6	5	4	3	2	1	0
1	0	1	LOOPCOUNT					ADDR	STEPNUMBER						

TABLE 15. Description of Command Bit Fields of the BRANCH Command

Bit or Field	Value	Description
LOOPCOUNT	0	Loop until a STOP PWM SCRIPT command is issued by the host.
	1 - 63	Number of loops to perform.
ADDR	0	Absolute addressing
	1	Relative addressing
STEPNUMBER	0 - 63	Depending on ADDR: ADDR=0: Addr to jump to ADDR=1: Number of backward steps

13.2.5 TRIGGER COMMAND

Triggers are used to synchronize operations between PWM channels. A TRIGGER command that sends a trigger takes sixteen 32.768 kHz clock cycles, and a command that waits for a trigger takes at least sixteen 32.768 kHz clock cycles.

A TRIGGER command that waits for a trigger (or triggers) will stall script execution until the trigger conditions are satisfied.

On trigger it will clear the trigger(s) and continue to the next command.

When a trigger is sent, it is stored by the receiving channel and can only be cleared when the receiving channel executes a TRIGGER command that waits for the trigger.

TABLE 16. TRIGGER Command Bit Fields

15	14	13	12	11	10	9	8	7	6	5	4	3	2	1	0
1	1	1	WAITTRIGGER					SENDTRIGGER							0

TABLE 17. Description of Command Bit Fields

Field	Value	Description
WAITTRIGGER	000xx1	Wait for trigger from channel 0
	000x1x	Wait for trigger from channel 1
	0001xx	Wait for trigger from channel 2
SENDTRIGGER	000xx1	Send trigger to channel 0
	000x1x	Send trigger to channel 1
	0001xx	Send trigger to channel 2

13.2.6 END COMMAND

The END command terminates script execution. It will only assert an interrupt to the host if the INT bit is set to "1".

When the END command is executed, the PWM output will be set to the level defined by PWMCFG.PWMPOL for this channel. Also, the script counter is reset back to the beginning of the script command buffer.

Please note: If a PWM channel is waiting for the trigger (last executed command was "TRIGGER") and the script execution is halted then the "END" command can't be executed

because the previous command is still pending. This is an exception - in this case the IRQ signal will not be asserted.

TABLE 18. END Command Bit Fields

15	14	13	12	11	10	9	8	7	6	5	4	3	2	1	0
1	1	0	1	INT	0										

TABLE 19. Description of Command Bit Fields of the END Command

Field	Value	Description
INT	0	No interrupt will be sent.
	1	Set TIMRIS.CDIRQ for this PWM channel to notify that program has ended.

14.0 LM8327 Register Set

14.1 KEYBOARD REGISTERS AND KEYBOARD CONTROL

Keyboard selection and control registers are mapped in the address range from 0x01 to 0x10. This paragraph describes the functions of the associated registers down to the bit level.

14.1.1 KBDSETTLE - Keypad Settle Time Register

TABLE 20. KBDSETTLE - Keypad Settle Time Register

Register - Name	Address	Type	Register Function
KBDSETTLE	0x01	R/W	Initial time for keys to settle, before the key-scan process is started.
Bit - Name	Bit	Default	Bit Function
WAIT[7:0]	7:0	0x80	The default value 0x80 : 0xBF sets a time target of 12 msec Further time targets are as follows: 0xC0 - 0xFF: 16 msec 0x80 - 0xBF: 12 msec 0x40 - 0x7F: 8 msec 0x01 - 0x3F: 4 msec 0x00 : no settle time

14.1.2 KBDBOUNCE - Debounce Time Register

TABLE 21. KBDBOUNCE - Debounce Time Register

Register - Name	Address	Type	Register Function
KBDBOUNCE	0x02	R/W	Time between first detection of key and final sampling of key.
Bit - Name	Bit	Default	Bit Function
WAIT[7:0]	7:0	0x80	The default value 0x80 : 0xBF sets a time target of 12 msec. Further time targets are as follows: 0xC0 - 0xFF: 16 msec 0x80 - 0xBF: 12 msec 0x40 - 0x7F: 8 msec 0x01 - 0x3F: 4 msec 0x00: no debouncing time

14.1.3 KBDSIZE - Set Keypad Size Register

TABLE 22. KBDSIZE - Set Keypad Size Register

Register - Name	Address	Type	Register Function
KBDSIZE	0x03	R/W	Defines the physical keyboard matrix size.
Bit - Name	Bit	Default	Bit Function
ROWSIZE[3:0]	7:4	0x2	Number of rows in the keyboard matrix: 0x0: free all rows to become GPIO, KPX[1:0] used as dedicated key inputs if scanning is enabled by CLKEN.KBEN. 0x1: (illegal value) 0x2 - 0x8: Number of rows in the matrix
COLSIZE[3:0]	3:0	0x2	Number of columns in the keyboard matrix: 0x0: free all rows to become GPIO, KPY[1:0] used as dedicated key inputs if scanning is enabled by CLKEN.KBEN 0x1: (illegal value) 0x2 - 0xC: Number of columns in the matrix

14.1.4 KBDEDCFG - Dedicated Key Register

TABLE 23. KBDEDCFG - Dedicated Key Register

Register - Name	Address	Type	Register Function
KBDEDCFG	0x04	R/W	Defines if a key is used as a standard keyboard/GPIO pin or whether it is used as dedicated key input.
Bit - Name	Bit	Default	Bit Function
ROW[7:2]	15:10	0x3F	Each bit in ROW [7:2] corresponds to ball KPX7 : KPX2. Bit=0: the dedicated key function applies. Bit=1: no dedicated key function is selected. The standard GPIO functionality applies according to register IOCFG or defined keyboard matrix.
COL[11:10]	9:8	0x03	Each bit in COL [11:10] corresponds to ball KPY11 : KPY10. Bit=0: the dedicated key function applies. Bit=1: no dedicated key function is selected. The standard GPIO functionality applies according to register IOCFG or defined keyboard matrix.
COL[9:2]	7:0	0xFF	Each bit in COL [9:2] corresponds to ball KPY9 : KPY2 and can be configured individually. Bit=0: the dedicated key function applies. Bit=1: no dedicated key function is selected. The standard GPIO functionality applies according to register IOCFG or defined keyboard matrix.

14.1.5 KBDRIS - Keyboard Raw Interrupt Status Register

TABLE 24. KBDRIS - Keyboard Raw Interrupt Status Register

Register - Name	Address	Type	Register Function
KBDRIS	0x06	R	Returns the status of stored keyboard interrupts.
Bit - Name	Bit	Default	Bit Function
(reserved)	7:4		(reserved)
RELINT	3	0x0	Raw event lost interrupt. More than 8 keyboard events have been detected and caused the event buffer to overflow. This bit is cleared by setting bit EVTIC of the KBDIC register.
REVTINT	2	0x0	Raw keyboard event interrupt. At least one key press or key release is in the keyboard event buffer. Reading from EVTCODE until the buffer is empty will clear this interrupt.
RKLINT	1	0x0	Raw key lost interrupt indicates a lost key-code. This interrupt is asserted when RSINT has not been cleared upon detection of a new key press or key release, or when more than 4 keys are pressed simultaneously.
RSINT	0	0x0	Raw scan interrupt. Interrupt generated after keyboard scan, if the keyboard status has changed.

14.1.6 KBDMIS - Keypad Masked Interrupt Status Register

TABLE 25. KBDMIS - Keypad Masked Interrupt Status Register

Register - Name	Address	Type	Register Function
KBDMIS	0x07	R	Returns the status on masked keyboard interrupts after masking with the KBDMSK register.
Bit - Name			
(reserved)	7:4		(reserved)
MELINT	3	0x0	Masked event lost interrupt. More than 8 keyboard events have been detected and caused the event buffer to overflow. This bit is cleared by setting bit EVTIC of the KBDIC register.
MEVTINT	2	0x0	Masked keyboard event interrupt. At least one key press or key release is in the keyboard event buffer. Reading from EVTICODE until the buffer is empty will clear this interrupt.
MKLINT	1	0x0	Masked key lost interrupt. Indicates a lost key-code. This interrupt is asserted when RSINT has not been cleared upon detection of a new key press or key release, or when more than 4 keys are pressed simultaneously.
MSINT	0	0x0	Masked scan interrupt. Interrupt generated after keyboard scan, if the keyboard status has changed, after masking process.

14.1.7 KBDIC - Keypad Interrupt Clear Register

TABLE 26. KBDIC - Keypad Interrupt Clear Register

Register - Name	Address	Default	Register Function
KBDIC	0x08	W	Setting these bits clears Keypad active Interrupts.
Bit - Name			
SFOFF	7		Switches off scanning of special function (SF) keys, when keyboard has no special function layout. 0: keyboard layout and SF keys are scanned 1: only keyboard layout is scanned, SF keys are not scanned
(reserved)	6:2		(reserved)
EVTIC	1		Clear event buffer and corresponding interrupts REVTINT and RELINT by writing a 1 to this bit position.
KBDIC	0		Clear RSINT and RKLINT interrupt bits by writing a 1 to this bit position.

14.1.8 KBDMSK - Keypad Interrupt Mask Register

TABLE 27. KBDMSK - Keypad Interrupt Mask Register

Register - Name	Address	Type	Register Function
KBDMSK	0x09	R/W	Configures masking of keyboard interrupts. Masked interrupts do not trigger an event on the Interrupt output. In case the interrupt processes registers KBDCODE[3:0], MSKELINT and MSKEINT should be set to 1. When the Event FIFO is processed, MSKLINT and MSKSINT should be set. For keyboard polling operations, all bits should be set and the polling operation consists of reading out the EVTCODE.
Bit - Name	Bit	Default	Bit Function
(reserved)	7:4		(reserved)
MSKELINT	3	0x1	0: keyboard event lost interrupt RELINT triggers IRQ line 1: keyboard event lost interrupt RELINT is masked
MSKEINT	2	0x1	0: keyboard event interrupt REVINT triggers IRQ line 1: keyboard event interrupt REVINT is masked
MSKLINT	1	0x0	0: keyboard lost interrupt RKLINT triggers IRQ line 1: keyboard lost interrupt RKLINT is masked
MSKSINT	0	0x0	0: keyboard status interrupt RSINT triggers IRQ line 1: keyboard status interrupt RSINT is masked

14.1.9 KBDCODE0 - Keyboard Code Register 0

The key code detected by the keyboard scan can be read from the registers KBDCODE0: KBDCODE3. Up to 4 keys can be detected simultaneously. Each KBDCODE register includes a bit (MULTIKEY) indicating if another key has been detected.

Please note: Reading out all key code registers (KBDCODE0 to KBDCODE3) will automatically reset the keyboard scan interrupt RSINT the same way as an active write access into bit KBDIC of the interrupt clear register does. Reading 0x7F from the KBDCODE0 register means that no key was pressed.

TABLE 28. KBDCODE0 - Keyboard Code Register 0

Register - Name	Address	Default	Register Function
KBDCODE0	0x0B	R	Holds the row and column information of the first detected key.
Bit - Name	Bit	Default	Bit Function
MULTIKEY	7	0x0	If this bit is 1 another key is available in KBDCODE1 register.
KEYROW[2:0]	6:4	0x7	ROW index of detected key (0 to 7)
KEYCOL[3:0]	3:0	0xF	Column index of detected (0 to 11, 12 for special function key).

14.1.10 KBDCODE1 - Keyboard Code Register 1

TABLE 29. KBDCODE1 - Keyboard Code Register 1

Register - Name	Address	Default	Register Function
KBDCODE1	0x0C	R	Holds the row and column information of the second detected key.
Bit - Name	Bit	Default	Bit Function
MULTIKEY	7	0x0	If this bit is 1 another key is available in KBDCODE2 register.
KEYROW[2:0]	6:4	0x7	ROW index of detected key (0 to 7)
KEYCOL[3:0]	3:0	0xF	Column index of detected key (0 to 11, 12 for special function key).

14.1.11 KBDCODE2 - Keyboard Code Register 2

TABLE 30. KBDCODE2 - Keyboard Code Register 2

Register - Name	Address	Default	Register Function
KBDCODE2	0x0D	R	Holds the row and column information of the third detected key.
Bit - Name			
Bit	Bit	Default	Bit Function
MULTIKEY	7	0x0	If this bit is 1 another key is available in KBDCODE3 register.
KEYROW[2:0]	6:4	0x7	ROW index of detected key (0 to 7)
KEYCOL[3:0]	3:0	0xF	Column index of detected key (0 to 11, 12 for special function key).

14.1.12 KBDCODE3 - Keyboard Code Register 3

TABLE 31. KBDCODE3 - Keyboard Code Register 3

Register - Name	Address	Default	Register Function
KBDCODE3	0x0E	R	Holds the row and column information of the fourth detected key.
Bit - Name			
Bit	Bit	Default	Bit Function
MULTIKEY	7	0x0	If this bit is set to "1" then more than 4 keys are pressed simultaneously.
KEYROW[2:0]	6:4	0x7	ROW index of detected key (0 to 7)
KEYCOL[3:0]	3:0	0xF	Column index of detected key (0 to 11, 12 for special function key).

14.1.13 EVTCODE - Key Event Code Register

TABLE 32. EVTCODE - Key Event Code Register

Register - Name	Address	Default	Bit Function
EVTCODE	0x10	R	With this register a FIFO buffer is addressed storing up to 15 consecutive events. Reading the value 0x7F from this address means that the FIFO buffer is empty. See further details below. NOTE: Auto increment is disabled on this register. Multi-byte read will always read from the same address.
Bit - Name			
Bit	Bit	Default	Bit Function
RELEASE	7	0x0	This bit indicates, whether the keyboard event was a key press or a key release event. 0: key was pressed 1: key was released
KEYROW[2:0]	6:4	0x7	Row index of key that is pressed or released.
KEYCOL[3:0]	3:0	0xF	Column index of key that is pressed (0...11, 12 for special function key) or released.

14.2 PWM TIMER CONTROL REGISTERS

The LM8327 provides three host-programmable PWM outputs useful for smooth LED brightness modulation. All PWM

timer control registers are mapped in the range from 0x60 to 0x7F. This paragraph describes the functions of the associated registers down to the bit level.

14.2.1 TIMCFGx - PWM Timer 0, 1 and 2 Configuration Registers

TABLE 33. TIMCFGx - PWM Timer 0, 1 and 2 Configuration Registers

Register - Name	Address	Type	Register Function
TIMCFG0	0x60	R/W	This register configures interrupt masking and handles PWM start/stop control of the associated PWM channel.
TIMCFG1	0x68		
TIMCFG2	0x70		
Bit - Name			
(x = 0, 1 or 2)	Bit	Default	Bit Function

Register - Name	Address	Type	Register Function
CYCIRQxMSK	4	0x0	Interrupt mask for PWM CYCIRQx (see Table 37): 0: interrupt enabled 1: interrupt masked
(reserved)	3:0	0x0	(reserved)

14.2.2 PWMCFGx - PWM Timer 0, 1 and 2 Configuration Control Registers

TABLE 34. PWMCFGx - PWM Timer 0, 1 and 2 Configuration Control Registers

Register - Name	Address	Type	Register Function
PWMCFG0	0x61	R/W	This register defines interrupt masking and the output behavior for the associated PWM channel. PGEx is used to start and stop the PWM script execution. PWMENx sets the PWM output to either reflect the generated pattern or the value configured in PWMPOLx.
PWMCFG1	0x69		
PWMCFG2	0x71		
Bit - Name (x = 0, 1 or 2)	Bit	Default	Bit Function
CDIRQxMSK	3	0x0	Mask for CDIRQ: 0: CDIRQ enabled 1: CDIRQ disabled/masked
PGEx	2	0x0	Pattern Generator Enable. Start/Stop PWM command processing for this channel. Script execution is started always from beginning. 0: Pattern Generator disabled 1: Pattern Generator enabled
PWMENx	1	0x0	0: PWM disabled. PWM timer output assumes value programmed in PWMPOL. 1: PWM enabled
PWMPOLx	0	0x0	Off-state of PWM output, when PWMEN=0. 0: PWM off-state is low 1: PWM off-state is high

14.2.3 TIMSCALx - PWM Timer 0, 1 and 2 Prescale Registers

TABLE 35. TIMSCALx - PWM Timer 0, 1 and 2 Prescale Registers

Register - Name	Address	Type	Register Function
TIMSCAL0	0x62	R/W	The registers determine the divider of the CLKIN external clock. The resulting clock is only used for PWM generation. The value should only be changed while PWM is stopped. Since all 3 PWM channels use the same slow clock, TIMSCAL0 affects all 3 PWM channels. TIMSCAL1 and TIMSCAL2 are directly linked to TIMSCAL0.
TIMSCAL1	0x6A		
TIMSCAL2	0x72		
Bit - Name	Bit	Default	Bit Function
SCAL[7:0]	7:0	0x0	CLKIN is divided by (SCAL+1).

14.2.4 TIMSWRES - PWM Timer Software Reset Registers

TABLE 36. TIMSWRES - PWM Timer Software Reset Registers

Register - Name	Address	Type	Register Function
TIMSWRES	0x78	W	Reset control on all PWM timers. A reset forces the pattern generator to fetch the first pattern and stops it. Each reset stops all state-machines and timer. Patterns stored in the pattern configuration register remain unaffected. Interrupts on each timer are not cleared, they need to be cleared writing into register TIMIC.
Bit - Name	Bit	Default	Bit Function
(reserved)	7:3		(reserved)
SWRES2	2		Software reset of timer 2. 0: no action 1: Software reset on timer 2, needs not to be written back to 0.
SWRES1	1		Software reset of timer 1. 0: no action 1: Software reset on timer 1, needs not to be written back to 0.
SWRES0	0		Software reset of timer 0. 0: no action 1: software reset on timer 0, needs not to be written back to 0.

14.2.5 TIMRIS - PWM Timer Interrupt Status Register

TABLE 37. TIMRIS - PWM Timer Interrupt Status Register

Register - Name	Address	Type	Register Function
TIMRIS	0x7A	R	This register returns the raw interrupt status from the PMW timers 0, 1 and 2. CYCIRQx - Interrupt from the timers when PWM cycle is complete (applies to the current PWM command residing in the active command register of a PWM block). CDIRQx - Interrupt from the pattern generator when PWM pattern code is complete (applies to a completed task residing in the script buffer of a PWM block).
Bit - Name	Bit	Default	Bit Functions
(reserved)	7:6		(reserved)
CDIRQ2	5	0x0	Raw interrupt status for CDIRQ timer2: 0: no interrupt pending 1: unmasked interrupt generated
CDIRQ1	4	0x0	Raw interrupt status for CDIRQ timer1: 0: no interrupt pending 1: unmasked interrupt generated
CDIRQ0	3	0x0	Raw interrupt status for CDIRQ timer0: 0: no interrupt pending 1: unmasked interrupt generated
CYCIRQ2	2	0x0	Raw interrupt status for CYCIRQ timer2: 0: no interrupt pending 1: unmasked interrupt generated
CYCIRQ1	1	0x0	Raw interrupt status for CYCIRQ timer1: 0: no interrupt pending 1: unmasked interrupt generated

Register - Name	Address	Type	Register Function
CYCIRQ0	0	0x0	Raw interrupt status for CYCIRQ timer0: 0: no interrupt pending 1: unmasked interrupt generated

14.2.6 TIMMIS - PWM Timer Masked Interrupt Status Register

TABLE 38. TIMMIS - PWM Timer Masked Interrupt Status Register

Register - Name	Address	Type	Register Function
TIMMIS	0x7B	R	This register returns the masked interrupt status from the PMW timers 0, 1 and 2. The raw interrupt status (TIMRIS) is masked with the associated TIMCFGx.CYCIRQxMSK and PWMCFGx.CDIRQxMSK bits to get the masked interrupt status of this register. CYCIRQ - Interrupt from the timers when PWM cycle is complete (applies to the current PWM command residing in the active command register of a PWM block). CDIRQ - Interrupt from the pattern generator when PWM pattern code is complete (applies to a completed task residing in the script buffer of a PWM block).
Bit - Name	Bit	Default	Bit Function
(reserved)	7:6		(reserved)
CDIRQ2	5	0x0	Interrupt after masking, indicates active contribution to the interrupt ball, when set. Status for CDIRQ timer2: 0: no interrupt pending 1: interrupt generated
CDIRQ1	4	0x0	Interrupt after masking, indicates active contribution to the interrupt ball, when set. Status for CDIRQ timer1: 0: no interrupt pending 1: interrupt generated
CDIRQ0	3	0x0	Interrupt after masking, indicates active contribution to the interrupt ball, when set. Status for CDIRQ timer0: 0: no interrupt pending 1: interrupt generated
CYCIRQ2	2	0x0	Interrupt after masking, indicates active contribution to the interrupt ball, when set. Status for CYCIRQ timer2: 0: no interrupt pending 1: interrupt generated
CYCIRQ1	1	0x0	Interrupt after masking, indicates active contribution to the interrupt ball, when set. Status for CYCIRQ timer1: 0: no interrupt pending 1: interrupt generated
CYCIRQ0	0	0x0	Interrupt after masking, indicates active contribution to the interrupt ball, when set. Status for CYCIRQ timer0: 0: no interrupt pending 1: interrupt generated

14.2.7 TIMIC - PWM Timer Interrupt Clear Register

TABLE 39. TIMIC - PWM Timer Interrupt Clear Register

Register - Name	Address	Type	Register Function
TIMIC	0x7C	W	This register clears timer and pattern interrupts. CYCIRQ - Interrupt from the timers when PWM cycle is complete (applies to the current PWM command residing in the active command register of a PWM block). CDIRQ - Interrupt from the pattern generator when PWM pattern code is complete (applies to a completed task residing in the script buffer of a PWM block).
Bit - Name	Bit	Default	Bit Function
(reserved)	7:6		(reserved)
CDIRQ2	5		Clears interrupt CDIRQ timer2: 0: no effect 1: interrupt is cleared. Does not need to be written back to 0
CDIRQ1	4		Clears interrupt CDIRQ timer1: 0: no effect 1: interrupt is cleared. Does not need to be written back to 0
CDIRQ0	3		Clears interrupt CDIRQ timer0: 0: no effect 1: interrupt is cleared. Does not need to be written back to 0
CYCIRQ2	2		Clears interrupt CYCIRQ timer2: 0: no effect 1: interrupt is cleared. Does not need to be written back to 0
CYCIRQ1	1		Clears interrupt CYCIRQ timer1: 0: no effect 1: interrupt is cleared. Does not need to be written back to 0
CYCIRQ0	0		Clears interrupt CYCIRQ timer0: 0: no effect 1: interrupt is cleared. Does not need to be written back to 0

14.2.8 PWMWP - PWM Timer Pattern Pointer Register

TABLE 40. PWMWP - PWM Timer Pattern Pointer Register

Register - Name	Address	Type	Register Function
PWMWP	0x7D	R/W	Pointer to the pattern position inside the configuration register, which will be overwritten by the next write access to be PWMCFG register. NOTE: 1 pattern consist of 2 bytes and not the byte position (low or high). It is incremented by 1 every time a full PWMCFG register access (word) is performed.
Bit - Name	Bit	Default	Bit Function
(reserved)	7	0x0	(reserved)
POINTER[6:0]	6:0	0x0	0 ≤ POINTER < 32 : timer0 patterns 0 to 31 32 ≤ POINTER < 64 : timer1 patterns 0 to 31 64 ≤ POINTER < 96 : timer2 patterns 0 to 31 96 ≤ POINTER < 128: not valid

14.2.9 PWMCFG - PWM Script Register (Two Byte)

TABLE 41. PWMCFG - PWM Script Register

Register - Name	Address	Type	Register Function
PWMCFG	0x7E	W	Two byte pattern storage register for a PWM script command indexed by PWMWP. PWMWP is automatically incremented. To be applied by two consecutive parameter bytes in one I ² C Write Transaction. NOTE: Autoincrement is disabled on this register. Address will stay at 0x7E for each word access.
Bit - Name	Bit	Default	Bit Function
CMD[15:8]	15:8		High byte portion of a PWM script command.
CMD[7:0]	7:0		Low byte portion of a PWM script command.

14.3 INTERFACE CONTROL REGISTERS

The following section describes the functions of special control registers provided for the main controller.

The manufacturer code MFGCODE and the software revision number SWREV tell the main device which configuration file has to be used for this device.

NOTE: I2CSA and MFGCODE use the same address. They just differentiate in the access type:

- Write - I2CSA
- Read - MFGCODE

14.3.1 I2CSA - I²C-Compatible ACCESS.bus Slave Address Register

TABLE 42. I2CSA - I²C-Compatible ACCESS.bus Slave Address Register

Register - Name	Address	Type	Register Function
I2CSA	0x80	W	I ² C-compatible ACCESS.bus Slave Address. The address is internally applied after the next I ² C STOP.
Bit - Name			
SLAVEADDR[7:1]	7:1	0x45	7-bit address field for the I ² C-compatible ACCESS.bus slave address.
(reserved)	0		(reserved)

14.3.2 MFGCODE - Manufacturer Code Register

TABLE 43. MFGCODE - Manufacturer Code Register

Register - Name	Address	Type	Register Function
MFGCODE	0x80	R	Manufacturer code of the LM8327.
Bit - Name			
MFGBIT	7:0	0x00	8-bit field containing the manufacturer code.

14.3.3 SWREV - Software Revision Register

TABLE 44. SWREV - Software Revision Register

Register - Name	Address	Type	Register Function
SWREV	0x81	R	Software revision code of the LM8327. NOTE: Writing the SW revision with the inverted value triggers a reset (see SWRESET).
Bit - Name			
SWBIT	7:0	0xC4	8-bit field containing the SW Revision number.

14.3.4 SWRESET - Software Reset

TABLE 45. SWRESET - Software Reset Register

Register - Name	Address	Type	Register Function
SWRESET	0x81	W	Software reset. NOTE: the reset is only applied if the supplied parameter has the inverted value as SWBIT. Reading this register provides the software revision (see Table 44).
Bit - Name			
SWBIT	7:0		Reapply inverted value for software reset.

14.3.5 RSTCTRL - System Reset Register

This register allows to reset specific blocks of the LM8327. For global reset of the I/OExpander the I²C command 'General Call reset' is used (see [Section 10.1.6 Global Call Re-](#)

[set](#)). This will reset the slave address back to 0x8A. During an active reset of a module, the LM8327 blocks the access to the module registers. A read will return 0, write commands are ignored.

TABLE 46. RSTCTRL - System Reset Register

Register - Name	Address	Type	Register Function
RSTCTRL	0x82	R/W	Software reset of specific parts of the LM8327.
Bit - Name			
(reserved)	7:5		(reserved)
IRQRST	4	0x0	Interrupt controller reset. Does not change status on IRQN ball. Only controls IRQ module register. Interrupt status read out is not possible when this bit is set. 0: interrupt controller not reset 1: interrupt controller reset
TIMRST	3	0x0	Timer reset for Timers 0, 1, 2: 0: timer not reset 1: timer is reset
(reserved)	2	0x0	(reserved)
KBDRST	1	0x0	Keyboard interface reset: 0: keyboard is not reset 1: keyboard is reset
GPIRST	0	0x0	GENIO reset: 0: GENIO not reset 1: GENIO is reset.

14.3.6 RSTINTCLR - Clear NO Init/Power-On Interrupt Register

TABLE 47. RSTINTCLR - Clear NO Init/Power-On Interrupt Register

Register - Name	Address	Type	Register Function
RSTINTCLR	0x84	W	This register allows to de-assert the POR/No Init Interrupt set every time the device returns from RESET (either POR, HW or SW Reset), the IRQN line is assigned active (low) and the IRQST.PORIRQ bit is set.
Bit - Name			
reserved	7:1		(reserved)
IRQCLR	0		1: Clears the PORIRQ Interrupt signalled in IRQST register. 0: is ignored

14.3.7 CLKMODE - Clock Mode Register

TABLE 48. CLKMODE - Clock Mode Register

Register - Name	Address	Type	Register Function
CLKMODE	0x88	R/W	This register controls the current operating mode of the LM8327 device.
Bit - Name			
(reserved)	7:2		(reserved)
MODCTL[1:0]	1:0	0x01	Writing to 00 forces the device to immediately enter sleep mode, regardless of any autosleep configuration. Reading this bit returns the current operating mode, which should always be 01. 00: SLEEP Mode 01: Operation Mode 1x: Future modes

14.3.8 CLKCFG - Clock Configuration Register

TABLE 49. CLKCFG - Clock Configuration Register

Register - Name	Address	Type	Register Function
CLKCFG	0x89	R/W	Configures clock sources and power options of the device. NOTE: Don't change while a PWM script is in progress.
Bit - Name	Bit	Default	Bit Function
(reserved)	7	0x0	(reserved)
CLKSRCSEL[1:0]	6:5	0x2	00: (reserved) 01: use externally generated clock from CLKIN pin as PWM slow clock 1x: use internally generated PWM slow clock
(reserved)	4:0	0x0	(reserved)

14.3.9 CLKEN - Clock Enable Register

TABLE 50. CLKEN - Clock Enable Register

Register - Name	Address	Type	Register Function
CLKEN	0x8A	R/W	Controls the clock to different functional units. It shall be used to enable the functional blocks globally and independently.
Bit - Name	Bit	Default	Bit Function
CLKOUTEN	7:6	0x0	CLKOUT clock output enable: 00: CLKOUT clock disabled. Fixed to low level. 01: CLKOUT frequency = PWM slow clock frequency. 10: reserved 11: reserved
(reserved)	5:3		(reserved)
TIMEN	2	0x0	PWM Timer 0, 1, 2 clock enable: 0: Timer 0, 1, 2 clock disabled 1: Timer 0, 1, 2 clock enabled.
DKBDEN*	1	0x0	Direct Key clock enable (starts/stops direct key scan): 0: Direct Key clock disabled 1: Direct Key clock enabled
KBDEN*	0	0x0	Keyboard clock enable (starts/stops key scan): 0: Keyboard clock disabled 1: Keyboard clock enabled

*Note: Only one of KBDEN or DKBDEN of CLKEN register can be set at a time, since Direct Key functions cannot be used at the same time as Keypad (Matrix). Setting both bits to 1 at the same time will enable only Direct Key.

14.3.10 AUTOSLP - Autosleep Enable Register

TABLE 51. AUTOSLP - Autosleep Enable Register

Register - Name	Address	Type	Register Function
AUTOSLP	0x8B	R/W	This register controls the Auto Sleep function of the LM8327 device.
Bit - Name	Bit	Default	Bit Function
(reserved)	7:1		(reserved)
ENABLE	0	0x00	Enables automatic sleep mode after a defined activity time stored in the AUTOSLPT1 register: 1: Enable entering auto sleep mode 0: Disable entering auto sleep mode

14.3.11 AUTOSLPTI - Auto Sleep Time Register

TABLE 52. AUTOSLPTI - Auto Sleep Time Register

Register - Name	Address	Type	Register Function
AUTOSLPTIL AUTOSLPTIH	0x8C 0x8D	R/W	This register defines the activity time. If this time passes without any processing events then the device enters into sleep-mode, but only if AUTOSLP.ENABLE bit is set to 1.
Bit - Name	Bit	Default	Bit Function
(reserved)	15:11		(reserved)
UPTIME[10:8] UPTIME[7:0]	10:8 7:0	0x00 0xFF	Values of UPTIME[10:0] match to multiples of 4ms: 0x00: no autosleep, regardless if AUTOSLP.ENABLE is set 0x01: 4ms 0x02: 8ms 0x7A: 500 ms 0xFF: 1020 ms (default after reset) 0x100: 1024 ms 0x7FF: 8188 ms

14.3.12 IRQST - Global Interrupt Status Register

TABLE 53. IRQST - Global Interrupt Status Register

Register - Name	Address	Type	Register Function
IRQST	0x91	R	Returns the interrupt status from various on-chip function blocks. If any of the bits is set and an IRQN line is configured, the IRQN line is asserted active
Bit - Name	Bit	Default	Bit Function
PORIRQ	7	0x1	Supply failure on VCC. Also power-on is considered as an initial supply failure. Therefore, after power-on, the bit is set. 0: no failure recorded 1: Failure, device was completely reset and requires re-programming.
KBDIRQ	6	0x0	Keyboard interrupt (further key selection in keyboard module): 0: inactive 1: active
DKBDIRQ	5	0x0	Direct key interrupt (further key selection in direct key module): 0: inactive 1: active
(reserved)	4		(reserved)
TIM2IRQ	3	0x0	Timer2 expiry (CDIRQ or CYCIRQ): 0: inactive 1: active
TIM1IRQ	2	0x0	Timer1 expiry (CDIRQ or CYCIRQ): 0: inactive 1: active
TIM0IRQ	1	0x0	Timer0 expiry (CDIRQ or CYCIRQ): 0: inactive 1: active
GPIOIRQ	0	0x0	GPIO interrupt (further selection in GPIO module): 0: inactive 1: active

14.4 GPIO FEATURE CONFIGURATION

14.4.1 GPIO Feature Mapping

The LM8327 has a flexible I/O structure which allows user to dynamically assign different functionality to each ball. The functionality of each ball is determined by the complete configuration of the balls.

In general the following priority is given:

- Direct Key
- Keypad
- GPIO
- PWM

With this, each ball will be available as keypad, GPIO, or PWM unless it is specified to be a direct key. The configuration for

direct key, keypad, GPIO or PWM usage is defined by the following registers:

- DIRECTn
 - This register defines a ball as a direct key.
- KBDSIZE and KBDEDCFG
 - Both registers define a ball as either part of the keypad matrix or as dedicated key input. These settings have highest priority and will overwrite settings made in other registers.
- IOCFG
 - This register is used to define the usage of PWM[2:0] and EXTIO if not configured to be part of the keymatrix, to be used as GPIO.

TABLE 54. Ball Configuration Options

BALL	Module connectivity							
	GPIOSEL	BALLCFG						
		0x0	0x1	0x2	0x3	0x4	0x5	0x6
KPX[7:0]	not used	GPIO[7:0]	-	-	-	-	-	-
KPY[7:0]	not used	GPIO[15:8]	-	-	-	-	-	-
KPY8	not used	GPIO16	-	-	-	-	-	-
KPY9	not used	GPIO17	-	-	-	-	-	-
KPY10	not used	GPIO18	-	-	-	-	-	-
KPY11	not used	GPIO19	-	-	-	-	-	-
PWM0	GPIO20	PWM0	-	-	-	-	-	-
PWM1	GPIO21	PWM1	-	-	-	-	-	-
PWM2	GPIO22	PWM2	-	-	-	-	-	-
EXTIO	GPIO23	-	-	-	-	-	-	-

14.4.2 IOCGF - Input/Output Pin Mapping Configuration Register

TABLE 55. IOCGF - Input/Output Pin Mapping Configuration Register

Register - Name	Address	Type	Register Function
IOCFG	0xA7	W	Configures usage of PWM[2:0] and EXTIO if not used as primary function.
Bit - Name	Bit	Default	Bit Function
GPIOSEL	7:4		TBD
(reserved)	3		(reserved)
BALLCFG	2:0		Select column to configure, see Table 54

14.4.3 IOPC0 - Pull Resistor Configuration Register 0

TABLE 56. IOPC0 - Pull Resistor Configuration Register 0

Register - Name	Address	Type	Register Function
IOPC0*	0xAA	R/W	Defines the pull resistor configuration for balls KPX[7:0].
Bit - Name	Bit	Default	Bit Function
KPX7PR[1:0]	15:14	0x3	Resistor enable for KPX7 ball: 00: no pull resistor at ball 01: pull down resistor programmed 1x: pull up resistor programmed
KPX6PR[1:0]	13:12	0x3	Resistor enable for KPX6 ball: 00: no pull resistor at ball 01: pull down resistor programmed 1x: pull up resistor programmed
KPX5PR[1:0]	11:10	0x3	Resistor enable for KPX5 ball: 00: no pull resistor at ball 01: pull down resistor programmed 1x: pull up resistor programmed
KPX4PR[1:0]	9:8	0x3	Resistor enable for KPX4 ball: 00: no pull resistor at ball 01: pull down resistor programmed 1x: pull up resistor programmed
KPX3PR[1:0]	7:6	0x3	Resistor enable for KPX3 ball: 00: no pull resistor at ball 01: pull down resistor programmed 1x: pull up resistor programmed
KPX2PR[1:0]	5:4	0x3	Resistor enable for KPX2 ball: 00: no pull resistor at ball 01: pull down resistor programmed 1x: pull up resistor programmed
KPX1PR[1:0]	3:2	0x3	Resistor enable for KPX1 ball: 00: no pull resistor at ball 01: pull down resistor programmed 1x: pull up resistor programmed
KPX0PR[1:0]	1:0	0x3	Resistor enable for KPX0 ball: 00: no pull resistor at ball 01: pull down resistor programmed 1x: pull up resistor programmed

* Written values of 0x2 and 0x3 will always be read back as 0x3.

14.4.4 IOPC1 - Pull Resistor Configuration Register 1

TABLE 57. IOPC1 - Pull Resistor Configuration Register 1

Register - Name	Address	Type	Register Function
IOPC1**	0xAC	R/W	Defines the pull resistor configuration for balls KPY[7:0].
Bit - Name	Bit	Default	Bit Function
KPY7PR[1:0]	15:14	0x3	Resistor enable for KPY7 ball: 00: no pull resistor at ball 01: pull down resistor programmed 1x: pull up resistor programmed

Register - Name	Address	Type	Register Function
KPY6PR[1:0]	13:12	0x3	Resistor enable for KPY6 ball: 00: no pull resistor at ball 01: pull down resistor programmed 1x: pull up resistor programmed
KPY5PR[1:0]	11:10	0x3	Resistor enable for KPY5 ball: 00: no pull resistor at ball 01: pull down resistor programmed 1x: pull up resistor programmed
KPY4PR[1:0]	9:8	0x3	Resistor enable for KPY4 ball: 00: no pull resistor at ball 01: pull down resistor programmed 1x: pull up resistor programmed
KPY3PR[1:0]	7:6	0x3	Resistor enable for KPY3 ball: 00: no pull resistor at ball 01: pull down resistor programmed 1x: pull up resistor programmed
KPY2PR[1:0]	5:4	0x3	Resistor enable for KPY2 ball: 00: no pull resistor at ball 01: pull down resistor programmed 1x: pull up resistor programmed
KPY1PR[1:0]	3:2	0x3	Resistor enable for KPY1 ball: 00: no pull resistor at ball 01: pull down resistor programmed 1x: pull up resistor programmed
KPY0PR[1:0]	1:0	0x3	Resistor enable for KPY0 ball: 00: no pull resistor at ball 01: pull down resistor programmed 1x: pull up resistor programmed

** Written values of 0x2 and 0x3 will always be read back as 0x3.

14.4.5 IOPC2 - Pull Resistor Configuration Register 2

TABLE 58. IOPC2 - Pull Resistor Configuration Register 2

Register - Name	Address	Type	Register Function
IOPC2***	0xAE	R/W	Defines the pull resistor configuration for balls KPY[11:8], PWM[2:0], EXTIO.
Bit - Name	Bit	Default	Bit Function
EXTIO[1:0]	15:14	0x3	Resistor enable for EXTIO ball: 00: no pull resistor at ball 01: pull down resistor programmed 1x: pull up resistor programmed
PWM2[1:0]	13:12	0x3	Resistor enable for PWM2 ball: 00: no pull resistor at ball 01: pull down resistor programmed 1x: pull up resistor programmed
PWM1[1:0]	11:10	0x3	Resistor enable for PWM1 ball: 00: no pull resistor at ball 01: pull down resistor programmed 1x: pull up resistor programmed

Register - Name	Address	Type	Register Function
PWM0[1:0]	9:8	0x3	Resistor enable for PWM0 ball: 00: no pull resistor at ball 01: pull down resistor programmed 1x: pull up resistor programmed
KPY11PR[1:0]	7:6	0x3	Resistor enable for KPY11 ball: 00: no pull resistor at ball 01: pull down resistor programmed 1x: pull up resistor programmed
KPY10PR[1:0]	5:4	0x3	Resistor enable for KPY10 ball: 00: no pull resistor at ball 01: pull down resistor programmed 1x: pull up resistor programmed
KPY9PR[1:0]	3:2	0x3	Resistor enable for KPY9 ball: 00: no pull resistor at ball 01: pull down resistor programmed 1x: pull up resistor programmed
KPY8PR[1:0]	1:0	0x3	Resistor enable for KPY8 ball: 00: no pull resistor at ball 01: pull down resistor programmed 1x: pull up resistor programmed

*** Written values of 0x2 and 0x3 will always be read back as 0x3.

14.4.6 GPIOOME0 - GPIO Open Drain Mode Enable Register 0

TABLE 59. GPIOOME0 - GPIO Open Drain Mode Enable Register 0

Register - Name	Address	Type	Register Function
GPIOOME0	0xE0	R/W	Configures KPX[7:0] for Open Drain or standard output functionality. The Open Drain drive source is configured by GPIOOMS0.
Bit - Name	Bit	Default	Bit Function
KPX[7:0]ODE	7:0	0x0	Open Drain Enable on KPX[7:0]: 0: full buffer 1: open drain functionality

14.4.7 GPIOOMS0 - GPIO Open Drain Mode Select Register 0

TABLE 60. GPIOOMS0 - GPIO Open Drain Mode Select Register 0

Register - Name	Address	Type	Register Function
GPIOOMS0	0xE1	R/W	Configures the Open Drain drive source on KPX[7:0] if selected by GPIOOME0.
Bit - Name	Bit	Default	Bit Function
KPX[7:0]ODM	7:0	0x0	0: Only NMOS transistor is active in output driver stage. Output can be driven to gnd or Hi-Z. 1: Only PMOS transistor is active in output driver stage. Output can be driven to VCC or Hi-Z.

14.4.8 GPIOOME1 - GPIO Open Drain Mode Enable Register 1

TABLE 61. GPIOOME1 - GPIO Open Drain Mode Enable Register 1

Register - Name	Address	Type	Register Function
GPIOOME1	0xE2	R/W	Configures KPY[7:0] for Open Drain or standard output functionality. The Open Drain drive source is configured by GPIOOMS1.
Bit - Name	Bit	Default	Bit Function
KPY[7:0]ODE	7:0	0x0	Open Drain Enable on KPY[7:0]: 0: full buffer 1: open drain functionality

14.4.9 GPIOOMS1 - GPIO Open Drain Mode Select Register 1

TABLE 62. GPIOOMS1 - GPIO Open Drain Mode Select Register 1

Register - Name	Address	Type	Register Function
GPIOOMS1	0xE3	R/W	Configures the Open Drain drive source on KPY[7:0] if selected by GPIOOME1.
Bit - Name	Bit	Default	Bit Function
KPY[7:0]ODM	7:0	0x0	0: Only NMOS transistor is active in output driver stage. Output can be driven to GND or Hi-Z. 1: Only PMOS transistor is active in output driver stage. Output can be driven to VCC or Hi-Z.

14.4.10 GPIOOME2 - GPIO Open Drain Mode Enable Register 2

TABLE 63. GPIOOME2 - GPIO Open Drain Mode Enable Register 2

Register - Name	Address	Type	Register Function
GPIOOME2	0xE4	R/W	Configures KPY[11:8], PWM[2:0], EXTIO for Open Drain or standard output functionality. The Open Drain drive source is configured by GPIOOMS2.
Bit - Name	Bit	Default	Bit Function
EXTIOODM	7	0x0	Open Drain Enable on EXTIO: 0: full buffer 1: open drain functionality
PWM[2:0]ODM	6:4	0x0	Open Drain Enable on PWM[2:0]: 0: full buffer 1: open drain functionality
KPY[11:8]ODE	3:0	0x0	Open Drain Enable on KPY[11:8]: 0: full buffer 1: open drain functionality

14.4.11 GPIOOMS2 - GPIO Open Drain Mode Select Register 2

TABLE 64. GPIOOMS2 - GPIO Open Drain Mode Select Register 2

Register - Name	Address	Type	Register Function
GPIOOMS2	0xE5	R/W	Configures the Open Drain drive source on KPY[11:8], PWM[2:], EXTIO if selected by GPIOOME2.
Bit - Name	Bit	Default	Bit Function
EXTIOODM	7	0x0	0: only NMOS transistor is active in output driver stage. Output can be driven to GND or Hi-Z. 1: only PMOS transistor is active in output driver stage. Output can be driven to GND or Hi-Z.
PWM[2:0]ODM	6:4	0x0	same as above
KPY[11:8]ODM	3:0	0x0	same as above

14.5 GPIO DATA INPUT/OUTPUT

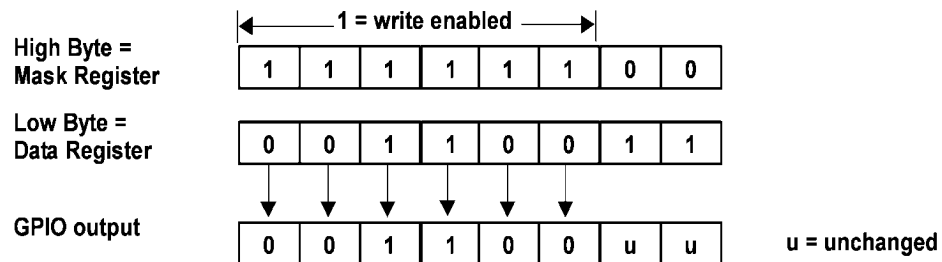

30124211

14.5.1 GPIODATA0 - GPIO Data Register 0

TABLE 65. GPIODATA0 - GPIO Data Register 0

Register - Name	Address	Type	Register Function
GPIODATA0	0xC0	R/W	This register is used for data input/output of KPX[7:0]. Every data I/O is masked with the associated MASK register. If one of the I/Os is defined as output (see Table 68) values written to this register are masked with MASK and then applied to the associated pin. If one of the I/Os is defined as input (see Table 68) values read from this register hold the masked input value of the associated pin.
Bit - Name	Bit	Default	Bit Function
MASK7	15	0x0	Mask Status for KPX7 when enabled as GPIO: 1: KPX7 enabled 0: KPX7 disabled
MASK6	14	0x0	Mask Status for KPX6 when enabled as GPIO: 1: KPX6 enabled 0: KPX6 disabled
MASK5	13	0x0	Mask Status for KPX5 when enabled as GPIO: 1: KPX5 enabled 0: KPX5 disabled
MASK4	12	0x0	Mask Status for KPX4 when enabled as GPIO: 1: KPX4 enabled 0: KPX4 disabled
MASK3	11	0x0	Mask Status for KPX3 when enabled as GPIO: 1: KPX3 enabled 0: KPX3 disabled

Register - Name	Address	Type	Register Function
MASK2	10	0x0	Mask Status for KPX2 when enabled as GPIO: 1: KPX2 enabled 0: KPX2 disabled
MASK1	9	0x0	Mask Status for KPX1 when enabled as GPIO: 1: KPX1 enabled 0: KPX1 disabled
MASK0	8	0x0	Mask Status for KPX0 when enabled as GPIO: 1: KPX0 enabled 0: KPX0 disabled
DATA7	7	0x0	Pin Status for KPX7 when enabled as GPIO.
DATA6	6	0x0	Pin Status for KPX6 when enabled as GPIO.
DATA5	5	0x0	Pin Status for KPX5 when enabled as GPIO.
DATA4	4	0x0	Pin Status for KPX4 when enabled as GPIO.
DATA3	3	0x0	Pin Status for KPX3 when enabled as GPIO.
DATA2	2	0x0	Pin Status for KPX2 when enabled as GPIO.
DATA1	1	0x0	Pin Status for KPX1 when enabled as GPIO.
DATA0	0	0x0	Pin Status for KPX0 when enabled as GPIO.

14.5.2 GPIOPDATA1 - GPIO Data Register 1

TABLE 66. GPIOPDATA1 - GPIO Data Register 1

Register - Name	Address	Type	Register Function
GPIOPDATA1	0xC2	R/W	This register is used for data input/output of KPY[7:0]. Every data I/O is masked with the associated MASK register. If one of the I/Os is defined as output (see Table 69) values written to this register are masked with MASK and then applied to the associated pin. If one of the I/Os is defined as input (see Table 69) values read from this register hold the masked input value of the associated pin.
Bit - Name	Bit	Default	Bit Function
MASK15	15	0x0	Mask Status for KPY7 when enabled as GPIO: 1: KPY7 enabled 0: KPY7 disabled
MASK14	14	0x0	Mask Status for KPY6 when enabled as GPIO: 1: KPY6 enabled 0: KPY6 disabled
MASK13	13	0x0	Mask Status for KPY5 when enabled as GPIO: 1: KPY5 enabled 0: KPY5 disabled
MASK12	12	0x0	Mask Status for KPY4 when enabled as GPIO: 1: KPY4 enabled 0: KPY4 disabled
MASK11	11	0x0	Mask Status for KPY3 when enabled as GPIO: 1: KPY3 enabled 0: KPY3 disabled
MASK10	10	0x0	Mask Status for KPY2 when enabled as GPIO: 1: KPY2 enabled 0: KPY2 disabled
MASK9	9	0x0	Mask Status for KPY1 when enabled as GPIO: 1: KPY1 enabled 0: KPY1 disabled

Register - Name	Address	Type	Register Function
MASK8	8	0x0	Mask Status for KPY0 when enabled as GPIO: 1: KPY0 enabled 0: KPY0 disabled
DATA15	7	0x0	Pin Status for KPY7 when enabled as GPIO.
DATA14	6	0x0	Pin Status for KPY6 when enabled as GPIO.
DATA13	5	0x0	Pin Status for KPY5 when enabled as GPIO.
DATA12	4	0x0	Pin Status for KPY4 when enabled as GPIO.
DATA11	3	0x0	Pin Status for KPY3 when enabled as GPIO.
DATA10	2	0x0	Pin Status for KPY2 when enabled as GPIO.
DATA9	1	0x0	Pin Status for KPY1 when enabled as GPIO.
DATA8	0	0x0	Pin Status for KPY0 when enabled as GPIO.

14.5.3 GPIODATA2 - GPIO Data Register 2

TABLE 67. GPIODATA2 - GPIO Data Register 2

Register - Name	Address	Type	Register Function
GPIODATA2	0xC4	R/W	This register is used for data input/output of KPY[11:8], PWM[2:0], EXTIO. Every data I/O is masked with the associated MASK register. If one of the I/Os is defined as output (see Table 70) values written to this register are masked with MASK and then applied to the associated pin. If one of the I/Os is defined as input (see Table 70) values read from this register hold the masked input value of the associated pin.
Bit - Name	Bit	Default	Bit Function
MASK23	15	0x0	Mask Status for EXTIO when enabled as GPIO: 1: EXTIO enabled 0: EXTIO disabled
MASK22	14	0x0	Mask Status for PWM2 when enabled as GPIO: 1: PWM2 enabled 0: PWM2 disabled
MASK21	13	0x0	Mask Status for PWM1 when enabled as GPIO: 1: PWM1 enabled 0: PWM1 disabled
MASK20	12	0x0	Mask Status for PWM0 when enabled as GPIO: 1: PWM0 enabled 0: PWM0 disabled
MASK19	11	0x0	Mask Status for KPY11 when enabled as GPIO: 1: KPY11 enabled 0: KPY11 disabled
MASK18	10	0x0	Mask Status for KPY10 when enabled as GPIO: 1: KPY10 enabled 0: KPY10 disabled
MASK17	9	0x0	Mask Status for KPY9 when enabled as GPIO: 1: KPY9 enabled 0: KPY9 disabled
MASK16	8	0x0	Mask Status for KPY8 when enabled as GPIO: 1: KPY8 enabled 0: KPY8 disabled
DATA23	7	0x0	Pin Status for EXTIO when enabled as GPIO.
DATA22	6	0x0	Pin Status for PWM2 when enabled as GPIO.
DATA21	5	0x0	Pin Status for PWM1 when enabled as GPIO.
DATA20	4	0x0	Pin Status for PWM0 when enabled as GPIO.

Register - Name	Address	Type	Register Function
DATA19	3	0x0	Pin Status for KPY11 when enabled as GPIO
DATA18	2	0x0	Pin Status for KPY10 when enabled as GPIO.
DATA17	1	0x0	Pin Status for KPY9 when enabled as GPIO.
DATA16	0	0x0	Pin Status for KPY8 when enabled as GPIO.

14.5.4 GPIODIR0 - GPIO Port Direction Register 0

TABLE 68. GPIODIR0 - GPIO Port Direction Register 0

Register - Name	Address	Type	Register Function
GPIODIR0	0xC6	R/W	Port direction for KPX[7:0].
Bit - Name	Bit	Default	Bit Function
KPX[7:0]DIR	7:0	0x00	Direction bits for KPX[7:0]: 0: input mode 1: output mode

14.5.5 GPIODIR1 - GPIO Port Direction Register 1

TABLE 69. GPIODIR1 - GPIO Port Direction Register 1

Register - Name	Address	Type	Register Function
GPIODIR1	0xC7	R/W	Port direction for KPY[7:0].
Bit - Name	Bit	Default	Bit Function
KPY[7:0]DIR	7:0	0x00	Direction bits for KPY[7:0]: 0: input mode 1: output mode

14.5.6 GPIODIR2 - GPIO Port Direction Register 2

TABLE 70. GPIODIR2 - GPIO Port Direction Register 2

Register - Name	Address	Type	Register Function
GPIODIR2	0xC8	R/W	Port direction for KPY[11:8], PWM[2:0], EXTIO.
Bit - Name	Bit	Default	Bit Function
EXTIODIR	7	0x0	Direction bits for EXTIO: 0: input mode 1: output mode
PWM[2:0]DIR	6:4	0x0	Direction bits for PWM[2:0]: 0: input mode 1: output mode
KPY[11:8]DIR	3:0	0x00	Direction bits for KPY[11:8]: 0: input mode 1: output mode

14.6 GPIO INTERRUPT CONTROL

14.6.1 GPIOIS0 - Interrupt Sense Configuration Register 0

TABLE 71. GPIOIS0 - Interrupt Sense Configuration Register 0

Register - Name	Address	Type	Register Function
GPIOIS0	0xC9	R/W	Interrupt type on KPX[7:0].
Bit - Name	Bit	Default	Bit Function
KPX[7:0]IS	7:0	0x0	Interrupt type bits for KPX[7:0]: 0: edge sensitive interrupt 1: level sensitive interrupt

14.6.2 GPIOIS1 - Interrupt Sense Configuration Register 1

TABLE 72. GPIOIS1 - Interrupt Sense Configuration Register 1

Register - Name	Address	Type	Register Function
GPIOIS1	0xCA	R/W	Interrupt type on KPY[7:0].
Bit - Name	Bit	Default	Bit Function
KPY[7:0]IS	7:0	0x0	Interrupt type bits for KPY[7:0]: 0: edge sensitive interrupt 1: level sensitive interrupt

14.6.3 GPIOIS2 - Interrupt Sense Configuration Register 2

TABLE 73. GPIOIS2 - Interrupt Sense Configuration Register 2

Register - Name	Address	Type	Register Function
GPIOIS2	0xCB	R/W	Interrupt type on KPY[11:8], PWM[2:0], EXTIO.
Bit - Name	Bit	Default	Bit Function
EXTIOIS	7	0x0	Interrupt type bits for EXTIO: 0: edge sensitive interrupt 1: level sensitive interrupt
PWM[2:0]IS	6:4	0x0	Interrupt type bits for PWM[2:0]: 0: edge sensitive interrupt 1: level sensitive interrupt
KPY[11:8]IS	3:0	0x0	Interrupt type bits for KPY[11:8]: 0: edge sensitive interrupt 1: level sensitive interrupt

14.6.4 GPIOIBE0 - GPIO Interrupt Edge Configuration Register 0

TABLE 74. GPIOIBE0 - GPIO Interrupt Edge Configuration Register 0

Register - Name	Address	Type	Register Function
GPIOIBE0	0xCC	R/W	Defines whether an interrupt on KPX[7:0] is triggered on both edges or on a single edge. See Table 77 for the edge configuration.
Bit - Name	Bit	Default	Bit Function
KPX[7:0]IBE	7:0	0x0	Interrupt both edges bits for KPX[7:0]: 0: interrupt generated at the active edge 1: interrupt generated after both edges

14.6.5 GPIOIBE1 - GPIO Interrupt Edge Configuration Register 1

TABLE 75. GPIOIBE1 - GPIO Interrupt Edge Configuration Register 1

Register - Name	Address	Type	Register Function
GPIOIBE1	0xCD	R/W	Defines whether an interrupt on KPY[7:0] is triggered on both edges or on a single edge. See Table 78 for the edge configuration.
Bit - Name	Bit	Default	Bit Function
KPY[7:0]IBE	7:0	0x0	Interrupt both edges bits for KPY[7:0]: 0: interrupt generated at the configured edge 1: interrupt generated after both edges

14.6.6 GPIOIBE2 - GPIO Interrupt Edge Configuration Register 2

TABLE 76. GPIOIBE2 - GPIO Interrupt Edge Configuration Register 2

Register - Name	Address	Type	Register Function
GPIOIBE2	0xCE	R/W	Defines whether an interrupt on KPY[11:8], PWM[2:0], EXTIO is triggered on both edges or on a single edge. See Table 79 for the edge configuration.
Bit - Name	Bit	Default	Bit Function
EXTIOIBE	7	0x0	Interrupt both edges bits for EXTIO: 0: interrupt generated at the active edge 1: interrupt generated after both edges
PWM[2:0]IBE	6:4	0x0	Interrupt both edges bits for PWM[2:0]: 0: interrupt generated at the active edge 1: interrupt generated after both edges
KPY[11:8]IBE	3:0	0x0	Interrupt both edges bits for KPY[11:8]: 0: interrupt generated at the active edge 1: interrupt generated after both edges

14.6.7 GPIOIEV0 - GPIO Interrupt Edge Select Register 0

TABLE 77. GPIOIEV0 - GPIO Interrupt Edge Select Register 0

Register - Name	Address	Type	Register Function
GPIOIEV0	0xCF	R/W	Select Interrupt edge for KPX[7:0].
Bit - Name	Bit	Default	Bit Function
KPX[7:0]EV	7:0	0x0	Interrupt edge select from KPX[7:0]: 0: interrupt at low level or falling edge 1: interrupt at high level or rising edge

14.6.8 GPIOIEV1 - GPIO Interrupt Edge Select Register 1

TABLE 78. GPIOIEV1 - GPIO Interrupt Edge Select Register 1

Register - Name	Address	Type	Register Function
GPIOIEV1	0xD0	R/W	Select Interrupt edge for KPY[7:0].
Bit - Name	Bit	Default	Bit Function
KPY[7:0]EV	7:0	0x0	Interrupt edge select from KPY[7:0]: 0: interrupt at low level or falling edge 1: interrupt at high level or rising edge

14.6.9 GPIOIEV2 - GPIO Interrupt Edge Select Register 2

TABLE 79. GPIOIEV2 - GPIO Interrupt Edge Select Register 2

Register - Name	Address	Type	Register Function
GPIOIEV2	0xD1	R/W	Select Interrupt edge for KPY[11:8], PWM[2:0], EXTIO.
Bit - Name	Bit	Default	Bit Function
EXTIOEV	7	0x0	Interrupt edge select from EXTIO: 0: interrupt at low level or falling edge 1: interrupt at high level or rising edge
PWM[2:0]EV	6:4	0x0	Interrupt edge select from PWM[2:0]: 0: interrupt at low level or falling edge 1: interrupt at high level or rising edge
KPY[11:8]EV	3:0	0x0	Interrupt edge select from KPY[11:8]: 0: interrupt at low level or falling edge 1: interrupt at high level or rising edge

14.6.10 GPIOIE0 - GPIO Interrupt Enable Register 0

TABLE 80. GPIOIE0 - GPIO Interrupt Enable Register 0

Register - Name	Address	Type	Register Function
GPIOIE0	0xD2	R/W	Enable/disable interrupts on KPX[7:0].
Bit - Name	Bit	Default	Bit Function
KPX[7:0]IE	7:0	0x0	Interrupt enable on KPX[7:0]: 0: disable interrupt 1: enable interrupt

14.6.11 GPIOIE1 - GPIO Interrupt Enable Register 1

TABLE 81. GPIOIE1 - GPIO Interrupt Enable Register 1

Register - Name	Address	Type	Register Function
GPIOIE1	0xD3	R/W	Enable/disable interrupts on KPY[7:0]
Bit - Name	Bit	Default	Bit Function
KPY[7:0]IE	7:0	0x0	Interrupt enable on KPY[7:0]: 0: disable interrupt 1: enable interrupt

14.6.12 GPIOIE2 - GPIO Interrupt Enable Register 2

TABLE 82. GPIOIE2 - GPIO Interrupt Enable Register 2

Register - Name	Address	Type	Register Function
GPIOIE2	0xD4	R/W	Enable/disable interrupts on KPY[11:8], PWM[2:0], EXTIO.
Bit - Name	Bit	Default	Bit Function
EXTIOIE	7	0x0	Interrupt enable on EXTIO: 0: disable interrupt 1: enable interrupt
PWM[2:0]IE	6:4	0x0	Interrupt enable on PWM[2:0]: 0: disable interrupt 1: enable interrupt

Register - Name	Address	Type	Register Function
KPY[11:8]IE	3:0	0x0	Interrupt enable on KPY[11:8]: 0: disable interrupt 1: enable interrupt

14.6.13 GPIOIC0 - GPIO Clear Interrupt Register 0

TABLE 83. GPIOIC0 - GPIO Clear Interrupt Register 0

Register - Name	Address	Type	Register Function
GPIOIC0	0xDC	W	Clears the interrupt on KPX[7:0].
Bit - Name	Bit	Default	Bit Function
KPX[7:0]IC	7:0		Clear Interrupt on KPX[7:0]. 0: no effect 1: Clear corresponding interrupt

14.6.14 GPIOIC1 - GPIO Clear Interrupt Register 1

TABLE 84. GPIOIC1 - GPIO Clear Interrupt Register 1

Register - Name	Address	Type	Register Function
GPIOIC1	0xDD	W	Clears the interrupt on KPY[7:0].
Bit - Name	Bit	Default	Bit Function
KPY[7:0]IC	7:0		Clear Interrupt on KPY[7:0]. 0: no effect 1: Clear corresponding interrupt

14.6.15 GPIOIC2 - GPIO Clear Interrupt Register 2

TABLE 85. GPIOIC2 - GPIO Clear Interrupt Register 2

Register - Name	Address	Type	Register Function
GPIOIC2	0xDE	W	Clears the interrupt on KPY[11:8], PWM[2:0], EXTIO.
Bit - Name	Bit	Default	Bit Function
EXTIOIC	7		Clear interrupt on EXTIO: 0: no effect 1: Clear corresponding interrupt
PWM[2:0]IC	6:4		Clear interrupt on PWM[2:0]: 0: no effect 1: Clear corresponding interrupt
KPY[11:8]IC	3:0		Clear Interrupt on KPY[11:8]: 0: no effect 1: Clear corresponding interrupt

14.7 GPIO INTERRUPT STATUS

14.7.1 GPIORIS0 - Raw Interrupt Status Register 0

TABLE 86. GPIORIS0 - Raw Interrupt Status Register 0

Register - Name	Address	Type	Register Function
GPIORIS0	0xD6	R	Raw interrupt status on KPX[7:0].
Bit - Name	Bit	Default	Bit Function
KPX[7:0]RIS	7:0	0x0	Raw Interrupt status data on KPX[7:0]: 0: no interrupt condition at GPIO 1: interrupt condition at GPIO

14.7.2 GPIORIS1 - Raw Interrupt Status Register 1

TABLE 87. GPIORIS1 - Raw Interrupt Status Register 1

Register - Name	Address	Type	Register Function
GPIORIS1	0xD7	R	Raw interrupt status on KPY[7:0].
Bit - Name	Bit	Default	Bit Function
KPY[7:0]RIS	7:0	0x0	Raw Interrupt status data on KPY[7:0]: 0: no interrupt condition at GPIO 1: interrupt condition at GPIO

14.7.3 GPIORIS2 - Raw Interrupt Status Register 2

TABLE 88. GPIORIS2 - Raw Interrupt Status Register 2

Register - Name	Address	Type	Register Function
GPIORIS2	0xD8	R	Raw interrupt status on KPY[11:8], PWM[2:0], EXTIO.
Bit - Name	Bit	Default	Bit Function
EXTIORIS	7	0x0	Raw Interrupt status data on EXTIO: 0: no interrupt condition at GPIO 1: interrupt at GPIO is active
PWM[2:0]RIS	6:4	0x0	Raw Interrupt status data on PWM[2:0]: 0: no interrupt condition at GPIO 1: interrupt at GPIO is active
KPY[11:8]RIS	3:0	0x0	Raw Interrupt status data on KPY[11:8]: 0: no interrupt condition at GPIO 1: interrupt condition at GPIO

14.7.4 GPIOMIS0 - Masked Interrupt Status Register 0

TABLE 89. GPIOMIS0 - Masked Interrupt Status Register 0

Register - Name	Address	Type	Register Function
GPIOMIS0	0xD9	R	Masked interrupt status on KPX[7:0].
Bit - Name	Bit	Default	Bit Function
KPX[7:0]MIS	7:0	0x0	Masked Interrupt status data on KPX[7:0]: 0: no interrupt contribution from GPIO 1: interrupt GPIO is active

14.7.5 GPIOMIS1 - Masked Interrupt Status Register 1

TABLE 90. GPIOMIS1 - Masked Interrupt Status Register 1

Register - Name	Address	Type	Register Function
GPIOMIS1	0xDA	R	Masked interrupt status on KPY[7:0].
Bit - Name	Bit	Default	Bit Function
KPY[7:0]MIS	7:0	0x0	Masked Interrupt status data on KPY[7:0]: 0: no interrupt contribution from GPIO 1: interrupt GPIO is active

14.7.6 GPIOMIS2 - Masked Interrupt Status Register 2

TABLE 91. GPIOMIS2 - Masked Interrupt Status Register 2

Register - Name	Address	Type	Register Function
GPIOMIS2	0xDB	R	Masked interrupt status on KPY[11:8], PWM[2:0], EXTIO.
Bit - Name	Bit	Default	Bit Function
EXTIOMIS	7	0x0	Masked Interrupt status data on EXTIO: 0: no interrupt condition from GPIO 1: interrupt at GPIO is active
PWM[2:0]MIS	6:4	0x0	Masked Interrupt status data on PWM[2:0]: 0: no interrupt condition from GPIO 1: interrupt at GPIO is active
KPY[11:8]MIS	3:0	0x0	Masked Interrupt status data on KPY[11:8]: 0: no interrupt contribution from GPIO 1: interrupt GPIO is active

14.8 GPIO WAKE-UP CONTROL

14.8.1 GPIOWAKE0 - GPIO Wake-Up Register 0

TABLE 92. GPIOWAKE0 - GPIO Wake-Up Register 0

Register - Name	Address	Type	Register Function
GPIOWAKE0	0xE9	R/W	Configures wake-up conditions for KPX[7:0]. Each bit corresponds to a ball. When bit set, the corresponding ball contributes to wakeup from auto sleep mode.
Bit - Name	Bit	Default	Bit Function
KPX[7:0]WAKE	7:0	0x0	Wakeup enable on KPX[7:0]: 0: disable wakeup 1: enable wakeup

14.8.2 GPIOWAKE1 - GPIO Wake-Up Register 1

TABLE 93. GPIOWAKE1 - GPIO Wake-Up Register 1

Register - Name	Address	Type	Register Function
GPIOWAKE1	0xEA	R/W	Configures wake-up conditions for KPY[7:0]. Each bit corresponds to a ball. When bit set, the corresponding ball contributes to wakeup from auto sleep mode.
Bit - Name	Bit	Default	Bit Function
KPY[7:0]WAKE	7:0	0x0	Wakeup enable on KPX[7:0]: 0: disable wakeup 1: enable wakeup

14.8.3 GPIOWAKE2 - GPIO Wake-Up Register 2

TABLE 94. GPIOWAKE2 - GPIO Wake-Up Register 2

Register - Name	Address	Type	Register Function
GPIOWAKE2	0xEB	R/W	Configures wake-up conditions for KPY[11:8], PWM[2:0], EXTIO. Each bit corresponds to a ball. When bit set, the corresponding ball contributes to wakeup from auto sleep mode.
Bit - Name	Bit	Default	Bit Function
EXTIOWAKE	7	0x0	Wakeup enable on EXTIO: 0: disable wakeup 1: enable wakeup
PWM[2:0]WAKE	6:4	0x0	Wakeup enable on PWM[2:0]: 0: disable wakeup 1: enable wakeup
KPY[11:8]WAKE	3:0	0x0	Wakeup enable on KPY[11:8]: 0: disable wakeup 1: enable wakeup

14.9 DIRECT KEY REGISTERS AND DIRECT KEY CONTROL

Direct Key selection and control registers are mapped in the address range from 0xE6 to 0xF3. This paragraph describes the functions of the associated registers down to the bit level.

14.9.1 DEVTCODE - Direct Key Event Code Register

TABLE 95. DEVTCODE - Direct Key Event Code Register

Register - Name	Address	Type	Register Function
DEVTCODE	0xE6	R	With this register a FIFO buffer is addressed storing up to 15 consecutive events. Reading the value 0x3F from this address means that the FIFO buffer is empty and a key is not pressed. Reading the value 0x1F from this address means that the FIFO buffer is empty and a key is still pressed. DKBDRIS.DREVTINT bit is cleared as soon as this FIFO reaches its empty state. See further details below. NOTE: Auto increment is disabled on this register. Multi-byte read will always read from the same address.
Bit - Name	Bit	Default	Bit Function
(reserved)	7:6		(reserved)
DKEYSTAT	5	0x0	This bit indicates whether the direct key event was a key press or a key release event. 0: direct key was pressed 1: direct key was released.
DKEYCODE	4:0	0x1F	Column index of key is pressed (0...24, 25 for Direct keys).

14.9.2 DBOUNCE - Direct Key Debounce Time Register

TABLE 96. DBOUNCE - Direct Key Debounce Time Register

Register - Name	Address	Type	Register Function
DBOUNCE	0xE7	R/W	Time between first detection of key and final sampling of key.
Bit - Name			
(reserved)	7:5		(reserved)
DEBOUNCE	4:0	0x03	De-bounce time for direct keys. Values of DEBOUNCE[4:0] match to multiples of 3ms: 0x00: 0ms 0x01: 3ms 0x02: 6ms 0x03: 9ms 0x1F: 93 ms

14.9.3 DIRECT0 - Direct Key Register 0

The direct key settings. If not enabled as a direct key, then that pin follows the IOCFG and keypad registers. Direct Key

bits take priority over anything else. Direct key bits must be cleared before IOCFG is accessed to set other functions for the pins.

TABLE 97. DIRECT0 - Direct Key Register 0

Register - Name	Address	Type	Register Function
DIRECT0	0xEC	R/W	Enable Direct Key connections for DK[7:0].
Bit - Name			
DK[7:0]	7:0	0xFF	1: Direct Key connection 0: Direct Key follows IOCFG and keypad registers.

14.9.4 DIRECT1 - Direct Key Register 1

TABLE 98. DIRECT1 - Direct Key Register 1

Register - Name	Address	Type	Register Function
DIRECT1	0xED	R/W	Enable Direct Key connections for DK[15:8].
Bit - Name			
DK[15:8]	7:0	0xFF	1: Direct Key connection 0: Direct Key follows IOCFG and keypad registers.

14.9.5 DIRECT2 - Direct Key Register 2

TABLE 99. DIRECT2 - Direct Key Register 2

Register - Name	Address	Type	Register Function
DIRECT2	0xEE	R/W	Enable Direct Key connections for DK[23:16].
Bit - Name			
DK[23:16]	7:0	0xFF	1: Direct Key connection 0: Direct Key follows IOCFG and keypad registers.

14.9.6 DIRECT3 - Direct Key Register 3

TABLE 100. DIRECT3 - Direct Key Register 3

Register - Name	Address	Type	Register Function
DIRECT3	0xEF	R/W	Enable Direct Key connections for DK[25:24].
Bit - Name			
(reserved)	7:2		(reserved)
DK[25:24]	1:0	0x03	1: Direct Key connection 0: Direct Key follows IOCFG and keypad registers.

14.9.7 DKBDRIS - Direct Key Raw Interrupt Status Register

TABLE 101. DKBDRIS - Direct Key Raw Interrupt Status Register

Register - Name	Address	Type	Register Function
DKBDRIS	0xF0	R	Returns the status of stored direct key interrupts.
Bit - Name			
(reserved)	7:2		(reserved)
DRELINT	1	0x0	Raw event lost interrupt. More than 8 direct key events have been detected and caused the event buffer to overflow. This bit is cleared by setting bit DEVTIC of the DKBDIC register.
DREVTINT	0	0x0	Raw direct key event interrupt. At least one direct key press or direct key release is in the direct key event buffer. Reading from DEVTCODE until the buffer is empty will automatically clear this interrupt.

14.9.8 DKBDMIS - Direct Key Masked Interrupt Status Register

TABLE 102. DKBDMIS - Direct Key Masked Interrupt Status Register

Register - Name	Address	Type	Register Function
DKBDMIS	0xF1	R	Returns the status of masked direct key interrupts after masking with the DKBDMSK register.
Bit - Name			
(reserved)	7:2		(reserved)
DMELINT	1	0x0	Masked event lost interrupt. More than 8 direct key events have been detected and caused the event buffer to overflow. This bit is cleared by setting bit DEVTIC of the DKBDIC register.
DMEVTINT	0	0x0	Masked direct key event interrupt. At least one direct key press or direct key release is in the direct key event buffer. Reading from DEVTCODE until the buffer is empty will automatically clear this interrupt.

14.9.9 DKBDIC - Direct Key Interrupt Clear Register

TABLE 103. DKBDIC - Direct Key Interrupt Clear Register

Register - Name	Address	Type	Register Function
DKBDIC	0xF2	W	Setting these bits clears direct key active interrupts.
Bit - Name			
	Bit	Default	Bit Function
(reserved)	7:1		(reserved)
DEVTIC	0		Clear event buffer and corresponding interrupts DREVTINT and DRELINT by writing a '1' to this bit position.

14.9.10 DKBDMSK - Direct Key Interrupt Mask Register

TABLE 104. DKBDMSK - Direct Key Interrupt Mask Register

Register - Name	Address	Type	Register Function
DKBDMSK	0xF3	R/W	Configures masking of direct key interrupts. Masked interrupts do not trigger an event of the interrupt output.
Bit - Name			
	Bit	Default	Bit Function
(reserved)	7:2		(reserved)
MSKELINT	1	0x1	0: direct key event lost interrupt DRELINT triggers IRQ line 1: direct key event lost interrupt DRELINT is masked.
MSKEINT	0	0x1	0: direct key event interrupt DREVTINT triggers IRQ line 1: direct key event interrupt DREVTINT is masked.

15.0 Absolute Maximum Ratings *(Note 1)*

If Military/Aerospace specified devices are required, please contact the National Semiconductor Sales Office/Distributors for availability and specifications.

Supply Voltage (V_{CC})	-0.3V to 2.2V
Voltage at Generic IOs	-0.2V to $V_{CC} + 0.2V$
Voltage at Backdrive/Overvoltage IOs	-0.3V to +4.25V

Maximum Input Current Without Latchup	± 100 mA
ESD Protection Level (Human Body Model)	2kV
(Machine Model)	200V
(Charge Device Model)	750V
Total Current into V_{CC} Pin (Source)	100 mA
Total Current out of GND Pin (Sink)	100 mA
Storage Temperature Range	-65°C to +140°C

16.0 Electrical Characteristics

TABLE 105. DC ELECTRICAL CHARACTERISTICS

Datasheet min/max specification limits are guaranteed by design, test, or statistical analysis.

(Temperature: $-40^{\circ}\text{C} \leq T_A \leq +85^{\circ}\text{C}$, unless otherwise specified)

Parameter	Conditions	Min	Typ	Max	Units
Operating Voltage (V_{CC})	Core Supply Voltage	1.62		1.98	V
Maximum Input voltage for Backdrive/Overvoltage IOs				3.60	V
Supply Current (I_{DD}) <i>(Note 2, Note 3)</i>	Internal Clock = ON, all internal functional blocks running, No loads on pins, $V_{CC} = 1.8V$, $T_C = 1\mu\text{s}$ $T_A = 25^{\circ}\text{C}$		1.2	2.0	mA
Sleep Mode HALT Current (I_{HALT}) <i>(Note 4)</i>	$V_{CC} = 1.8V$, $T_A = 25^{\circ}\text{C}$ Internal Clock = OFF, no internal functional blocks running		<9	40	μA
IDLE Current	Internal Clock = ON, no internal functional blocks running		1		mA

TABLE 106. AC ELECTRICAL CHARACTERISTICS

(Temperature: $-40^{\circ}\text{C} \leq T_A \leq +85^{\circ}\text{C}$)

Data sheet specification limits are guaranteed by design, test, or statistical analysis.

Parameter	Conditions	Min	Typ	Max	Units
System Clock Frequency	Internal RC		10.5		MHz
System Clock Period (mclk)	$1.62V \leq V_{CC} \leq 1.98V$		95		ns
Internal RC Oscillator (t_C)	$1.62V \leq V_{CC} \leq 1.98V$		0.95		μs
Internal RC Oscillator Frequency Variation				± 7	%
ACCESS.bus Input Signals					
Bus Free Time Between Stop and Start Condition (t_{BUFI}) <i>(Note 5)</i>		16			
SCL Setup Time (t_{CSTOSi}) <i>(Note 5)</i>	Before Stop Condition	8			
SCL Hold Time (t_{CSTRhi}) <i>(Note 5)</i>	After Start Condition	8			
SCL Setup Time (t_{CSTRsi}) <i>(Note 5)</i>	Before Start Condition	8			
Data High Setup Time (t_{DHCsi}) <i>(Note 5)</i>	Before SCL Rising Edge (RE)	2			
<i>(Note 6)</i>					
Data Low Setup Time (t_{DLCsi}) <i>(Note 5)</i>	Before SCL RE	2			
<i>(Note 6)</i>					
SCL Low Time ($t_{SCLlowi}$) <i>(Note 5)</i>	After SCL Falling Edge (FE)	12			
SCL High Time ($t_{SCLhighi}$) <i>(Note 5)</i>	After SCL FE	12			
<i>(Note 6)</i>					
SDA Hold Time (t_{SDAhi}) <i>(Note 5)</i>	After SCL FE	0			
SDA Setup Time (t_{SDAsi}) <i>(Note 5)</i>	Before SCL RE	2			
<i>(Note 6)</i>					

Parameter	Conditions	Min	Typ	Max	Units
ACCESS.bus Output Signals SDA Hold Time (t_{SDAho}) (Note 5)	After SCL Falling Edge	2			mclk

TABLE 107. GENERAL GPIO CHARACTERISTICS

Characteristics for all pins except CLKIN, IRQN/KPY11/PWM2, SDA, and SCL in GPIO mode.

Parameter	Conditions	Min	Typ	Max	Units
V_{IH} (Min. Input High Voltage)		$0.7 \times V_{CC}$			V
V_{IL} (Max. Input Low Voltage)				$0.3 \times V_{CC}$	V
I_{Source}	$V_{CC} = 1.62$ $V_{OH} = 0.7 \times V_{CC}$			-16	mA
I_{Sink}	$V_{CC} = 1.62$ $V_{OL} = 0.3 \times V_{CC}$	16			mA
Allowable Sink current per pin (Note 7)				16	mA
I_{PU} (Weak Pull-UP Current) (Note 8)	$V_{OUT} = 0V$	-30		-160	μA
I_{PD} (Weak Pull-Down Current) (Note 8)	$V_{OUT} = V_{CC}$	30		160	
I_{OZ} (Input Leakage Current)	GPIO output disabled $V_{pin} = 0$ to V_{CC}			± 2	
$t_{Rise/Fall}$ (Max. Rise and Fall times) (Note 5)	$C_{LOAD} = 50$ pF			15	ns

TABLE 108. BACKDRIVE/OVERVOLTAGE I/O DC CHARACTERISTICS

Characteristics for pins CLKIN, IRQN/KPY11/PWM2, SDA and SCL

Parameter	Conditions	Min	Typ	Max	Units
V_{IH} (Min. Input High Voltage)		$0.7 \times V_{CC}$			V
V_{IL} (Max. Input Low Voltage)				$0.3 \times V_{CC}$	
I_{Source}	$V_{CC} = 1.62V$ $V_{OH} = 1.15V$			-6	mA
I_{Sink1} (as GPIO)	$V_{CC} = 1.62V$ $V_{OL} = 0.4V$	12			mA
I_{Sink2} (as ACCESS.bus)	$V_{CC} = 1.62V$ $V_{OL} = 0.4V$	3			mA
I_{Sink3} (as ACCESS.bus)	$V_{CC} = 1.62V$ $V_{OL} = 0.6V$	4			mA
Allowable Sink current per pin (Note 7)				12	mA
I_{PU} (Weak Pull-UP Current) (Note 8)	$V_{OUT} = 0V$	-7		-40	μA
I_{PD} (Weak Pull-Down Current) (Note 8)	$V_{OUT} = V_{CC}$	7		40	
I_{OZ1} (Input Leakage Current) (Note 9)	GPIO output disabled $V_{CC} = 1.62V$ to $1.98V$ $V_{pin} = 0$ to V_{CC} $V_{pin} = V_{CC}$ to $3.6V$			± 2 ± 10	
I_{OZ2} (Input Backdrive Leakage Current)	$0 \leq V_{CC} \leq 0.5V$ $V_{pin} = 0$ to $3.6V$			± 10	μA

TABLE 109. BACKDRIVE/OVERVOLTAGE I/O AC CHARACTERISTICS

Characteristics for pins CLKIN, IRQN/KPY11/PWM2, SDA and SCL

Parameter	Conditions	Min	Typ	Max	Units
$t_{Rise/Fall}$ (Max. Rise and Fall time) (Note 5)	$C_{LOAD} = 50$ pF @ 1MHz			70	ns
t_{Fall} (Max. Fall time) as ACCESS.bus (SDA, SCL only) (Note 5)	$C_{LOAD} = 10$ pF to 100 pF V_{IHmin} to V_{ILmax}	10		120	

- Note 1:** Absolute Maximum Ratings indicate limits beyond which damage to the device may occur. DC and AC electrical specifications are not ensured when operating the device at absolute maximum ratings.
- Note 2:** Supply and IDLE current is measured with inputs connected to V_{CC} and outputs driven low but not connected to a load.
- Note 3:** Values are estimates. Values will be updated after characterization is completed.
- Note 4:** In sleep mode, the internal clock is switched off. Supply current in sleep mode is measured with inputs connected to V_{CC} and outputs driven low but not connected to a load.
- Note 5:** Guaranteed by design, not tested.
- Note 6:** The ACCESS.bus interface implements and meets the timings necessary for interface to the I²C and SMBus protocols at logic levels. The bus drivers have open-drain outputs for bidirectional operation. Due to Internal RC Oscillator Frequency Variation, this specification may not meet the AC timing and current/voltage drive requirements of the full-bus specifications.
- Note 7:** The sum of all I/O sink/source current must not exceed the maximum total current into V_{CC} and out of GND as specified in the absolute maximum ratings.
- Note 8:** This is the internal weak pull-up (pull-down) current when driver output is disabled. If enabled, during receiving mode, this is the current required to switch the input from one state to another.
- Note 9:** I_{OZ1} for CLKIN is max 60 μ A if $V_{PIN} > V_{CC}$ because the weak pull-down is enabled.

17.0 Registers

17.1 REGISTER MAPPING

17.1.1 Keyboard Registers

Table 110 shows the register map for keyboard functionality. In addition to Global Call Reset (see [Section 10.1.6 Global Call Reset](#)) or Software Reset using SWRESET (see [Table](#)

45), these registers are reset to 0x00 values by a module reset using RSTCTRL.KBDRST and should be rewritten for desired settings (see RSTCTRL - [Section 14.3.5 RSTCTRL - System Reset Register](#)).

TABLE 110. Register Map for Keyboard Functionality

Register Name	Description	Register File Address	Register Type	ACCESS Size	Default value	Next RF Address
KBDSETTLE	Keypad Settle Time	0x01	R/W	byte	0x80	0x02
KBDBOUNCE	Keypad Debounce Time	0x02	R/W	byte	0x80	0x03
KBDSIZE	Keypad Size Configuration	0x03	R/W	byte	0x22	0x04
KBDEDCFG0	Keypad Dedicated Key 0	0x04	R/W	byte	0xFF	0x05
KBDEDCFG1	Keypad Dedicated Key 1	0x05	R/W	byte	0xFF	0x06
KBDRIS	Keypad Raw Interrupt Status	0x06	R	byte	0x00	0x07
KBDMIS	Keypad Masked Interrupt Status	0x07	R	byte	0x00	0x08
KBDIC	Keypad Interrupt Clear	0x08	W	byte		0x09
KBDMSK	Keypad Interrupt Mask	0x09	R	byte	0x0C	0x0A
KBDCODE0	Keypad Code 0	0x0B	R	byte	0x7F	0x0C
KBDCODE1	Keypad Code 1	0x0C	R	byte	0x7F	0x0D
KBDCODE2	Keypad Code 2	0x0D	R	byte	0x7F	0x0E
KBDCODE3	Keypad Code 3	0x0E	R	byte	0x7F	0x0F
EVTCODE	Key Event Code	0x10	R	byte	0x7F	0x10

17.1.2 Direct Key Registers

Table 111 shows the register map for keyboard functionality when using direct keys. In addition to Global Call Reset (see [Section 10.1.6 Global Call Reset](#)) or Software Reset using SWRESET (see [Section 14.3.4 SWRESET - Software Re-](#)

[set](#)), these registers are reset to 0x00 values by a module reset using RSTCTRL.KBDRST and should be rewritten for desired settings (see RSTCTRL, [Section 14.3.5 RSTCTRL - System Reset Register](#)).

TABLE 111. Register Map for Direct Key Registers

Register Name	Description	Register File Address	Register Type	ACCESS Size	Default value	Next RF Address
DEVTCODE	Direct Key Event Code	0xE6	R	byte	0x3F	0xE6
DBOUNCE	Direct Key Debounce Time	0xE7	R/W	byte	0x03	0xE8
DIRECT0	Direct Key Config 0	0xEC	R/W	byte	0xFF	0xED
DIRECT1	Direct Key Config 1	0xED	R/W	byte	0xFF	0xEE
DIRECT2	Direct Key Config 2	0xEE	R/W	byte	0xFF	0xEF
DIRECT3	Direct Key Config 3	0xEF	R/W	byte	0x03	0xF0
DKBDRIS	Direct Key Raw Interrupt Status	0xF0	R	byte	0x00	0xF1
DKBDMIS	Direct Key Masked Int. Status	0xF1	R	byte	0x00	0xF2
DKBDIC	Direct Key Interrupt Clear	0xF2	W	byte		0xF3
DKBDMSK	Direct Key Interrupt Mask	0xF3	R/W	byte	0x03	0xF4

17.1.3 PWM Timer Registers

Table 112 shows the register map for PWM Timer functionality. In addition to Global Call Reset (see [Section 10.1.6 Global Call Reset](#)) or Software Reset using SWRESET (see [Table 45](#)), these registers are reset to default values by a module reset using RSTCTRL.TIMRST (see [Section 14.3.5 RSTCTRL - System Reset Register](#)).

TABLE 112. Register Map for PWM Timer Functionality

Register Name	Description	Register File Address	Register Type	ACCESS Size	Default value	Next RF Address
TIMCFG0	PWM Timer Configuration 0	0x60	R/W	byte	0x00	0x61
PWMCFG0	PWM Configuration 0	0x61	R/W	byte	0x00	0x62
TIMSCAL0	PWM Timer Prescaler 0	0x62	R/W	byte	0x00	0x63
TIMCFG1	PWM Timer Configuration 1	0x68	R/W	byte	0x00	0x69
PWMCFG1	PWM Configuration 1	0x69	R/W	byte	0x00	0x6A
TIMSCAL1	PWM Timer Prescaler 1	0x6A	R/W	byte	0x00	0x6B
TIMCFG2	PWM Timer Configuration 2	0x70	R/W	byte	0x00	0x71
PWMCFG2	PWM Configuration 2	0x71	R/W	byte	0x00	0x72
TIMSCAL2	PWM Timer Prescaler 2	0x72	R/W	byte	0x00	0x73
TIMSWRES	PWM Timer SW Reset	0x78	W	byte		0x79
TIMRIS	PWM Timer Interrupt Status	0x7A	R	byte	0x00	0x7B
TIMMIS	PWM Timer Masked Int. Status	0x7B	R	byte	0x00	0x7C
TIMIC	Timer Interrupt Clear	0x7C	W	byte		0x7D
PWMWP	PWM Command Write Pointer	0x7D	R/W	byte	0x00	0x7E
PWMCFG	PWM Command Script	0x7E	W	word		0x7F

17.1.4 System Registers

Table 113 shows the register map for general system registers. These registers are not affected by any of the module resets addressed by RSTCTRL (see Section 14.3.5 RSTCTRL - System Reset Register).

These registers can only be reset to default values by a Global Call Reset (see Section 10.1.6 Global Call Reset) or by a complete Software Reset using SWRESET (see Table 45).

TABLE 113. Register Map for System Control Functionality

Register Name	Description	Register File Address	Register Type	ACCESS Size	Default value	Next RF Address
I2CSA	I ² C Slave Address	0x80	W	byte	0x8A	0x81
MFGCODE	Manufacturer Code	0x80	R	byte	0x00	0x81
SWREV	SW Revision	0x81	R	byte	0xC4	0x82
SWRESET	SW Reset	0x81	W	byte		0x82
RSTCTRL	System Reset	0x82	R/W	byte	0x00	0x83
RSTINTCLR	Clear No Init/Power On Interrupt	0x84	W	byte		0x85
CLKMODE	Clock Mode	0x88	R/W	byte	0x01	0x89
CLKCFG	Clock Configuration	0x89	R/W	byte	0x40	0x8A
CLKEN	Clock Enable	0x8A	R/W	byte	0x00	0x8B
AUTOSLP	Auto Sleep Enable	0x8B	R/W	byte	0x00	0x8C
AUTOSLPTI	Auto Sleep Time	0x8C	R/W	word	0x00FF	0x8D
MMMASTER	Multi-Master Mode	0xF4	R/W	byte	0x00	0xF5

17.1.5 Global Interrupt Registers

Table 114 shows the register map for global interrupt functionality. In addition to Global Call Reset (see Section 10.1.6 Global Call Reset) or Software Reset using SWRESET (see

Table 45), these registers are reset to default values by a module reset using RSTCTRL.IRQRST (see Section 14.3.5 RSTCTRL - System Reset Register).

TABLE 114. Register Map for Global Interrupt Functionality

Register Name	Description	Register File Address	Register Type	ACCESS Size	Default value	Next RF Address
IRQST	Global Interrupt Status	0x91	R	byte	0x80	0x92

17.1.6 GPIO Registers

Table 115 shows the register map for GPIO functionality. In addition to Global Call Reset (see Section 10.1.6 Global Call Reset) or Software Reset using SWRESET (see Table 45),

these registers are reset to 0x00 values by a module reset using RSTCTRL.GPIRST and should be rewritten for desired settings (see Section 14.3.5 RSTCTRL - System Reset Register).

TABLE 115. Register Map for GPIO Functionality

Register Name	Description	Register File Address	Register Type	ACCESS Size	Default value	Next RF Address
IOCFG	I/O Pin Mapping Configuration	0xA7	W	byte		0xA8
IOPC0	Pull Resistor Configuration 0	0xAA	R/W	word	0xFFFF	0xAB
IOPC1	Pull Resistor Configuration 1	0xAC	R/W	word	0xFFFF	0xAD
IOPC2	Pull Resistor Configuration 2	0xAE	R/W	word	0xFFFF	0xAF
GPIODATA0	GPIO I/O Data 0	0xC0	R/W	byte	0x00	0xC1
GPIOMASK0	GPIO I/O Mask 0	0xC1	W	byte		0xC2
GPIODATA1	GPIO I/O Data 1	0xC2	R/W	byte	0x00	0xC3
GPIOMASK1	GPIO I/O Mask 1	0xC3	W	byte		0xC4
GPIODATA2	GPIO I/O Data 2	0xC4	R/W	byte	0x00	0xC5
GPIOMASK2	GPIO I/O Mask 2	0xC5	W	byte		0xC6
GPIODIR0	GPIO I/O Direction 0	0xC6	R/W	byte	0x00	0xC7
GPIODIR1	GPIO I/O Direction 1	0xC7	R/W	byte	0x00	0xC8

Register Name	Description	Register File Address	Register Type	ACCESS Size	Default value	Next RF Address
GPIODIR2	GPIO I/O Direction 2	0xC8	R/W	byte	0x00	0xC9
GPIOIS0	GPIO Int Sense Config 0	0xC9	R/W	byte	0x00	0xCA
GPIOIS1	GPIO Int Sense Config 1	0xCA	R/W	byte	0x00	0xCB
GPIOIS2	GPIO Int Sense Config 2	0xCB	R/W	byte	0x00	0xCC
GPIOIBE0	GPIO Int Both Edges Config 0	0xCC	R/W	byte	0x00	0xCD
GPIOIBE1	GPIO Int Both Edges Config 1	0xCD	R/W	byte	0x00	0xCE
GPIOIBE2	GPIO Int Both Edges Config 2	0xCE	R/W	byte	0x00	0xCF
GPIOIEV0	GPIO Int Edge Select 0	0xCF	R/W	byte	0x00	0xD0
GPIOIEV1	GPIO Int Edge Select 1	0xD0	R/W	byte	0x00	0xD1
GPIOIEV2	GPIO Int Edge Select 2	0xD1	R/W	byte	0x00	0xD2
GPIOIE0	GPIO Interrupt Enable 0	0xD2	R/W	byte	0x00	0xD3
GPIOIE1	GPIO Interrupt Enable 1	0xD3	R/W	byte	0x00	0xD4
GPIOIE2	GPIO Interrupt Enable 2	0xD4	R/W	byte	0x00	0xD5
GPIORIS0	GPIO Raw Int Status 0	0xD6	R	byte	0x00	0xD7
GPIORIS1	GPIO Raw Int Status 1	0xD7	R	byte	0x00	0xD8
GPIORIS2	GPIO Raw Int Status 2	0xD8	R	byte	0x00	0xD9
GPIOMIS0	GPIO Masked Int Status 0	0xD9	R	byte	0x00	0xDA
GPIOMIS1	GPIO Masked Int Status 1	0xDA	R	byte	0x00	0xDB
GPIOMIS2	GPIO Masked Int Status 2	0xDB	R	byte	0x00	0xDC
GPIOIC0	GPIO Interrupt Clear 0	0xDC	W	byte		0xDD
GPIOIC1	GPIO Interrupt Clear 1	0xDD	W	byte		0xDE
GPIOIC2	GPIO Interrupt Clear 2	0xDE	W	byte		0xDF
GPIOOMEO	GPIO Open Drain Mode Enable 0	0xE0	R/W	byte	0x00	0xE1
GPIOOMS0	GPIO Open Drain Mode Select 0	0xE1	R/W	byte	0x00	0xE2
GPIOOME1	GPIO Open Drain Mode Enable 1	0xE2	R/W	byte	0x00	0xE3
GPIOOMS1	GPIO Open Drain Mode Select 1	0xE3	R/W	byte	0x00	0xE4
GPIOOME2	GPIO Open Drain Mode Enable 2	0xE4	R/W	byte	0x08	0xE5
GPIOOMS2	GPIO Open Drain Mode Select 2	0xE5	R/W	byte	0x00	0xE6
GPIOWAKE0	GPIO Wakeup Enable 0	0xE9	R/W	byte	0x00	0xEA
GPIOWAKE1	GPIO Wakeup Enable 1	0xEA	R/W	byte	0x00	0xEB
GPIOWAKE2	GPIO Wakeup Enable 2	0xEB	R/W	byte	0x00	0xEC

TABLE 116. REGISTER LAYOUT - Control Bits in LM8327 Registers

Register	Addr.	BIT 7	BIT 6	BIT 5	BIT 4	BIT 3	BIT 2	BIT 1	BIT 0
KBDSETTLE	0x01								
KBDBOUNCE	0x02								
Wait[7:0]									
Wait[7:0]									
KBDSIZE	0x03	ROWSIZE3	ROWSIZE2	ROWSIZE1	ROWSIZE0	COLSIZE3	COLSIZE2	COLSIZE1	COLSIZE0
KBDDDCFG0	0x04	COL9	COL8	COL7	COL6	COL5	COL4	COL3	COL2
KBDDDCFG1	0x05	ROW7	ROW6	ROW5	ROW4	ROW3	ROW2	COL11	COL10
KBDRIS	0x06					RELINT	REVTINT	RKLINT	RSINT
KBDMIS	0x07					MELINT	MEVTINT	MKLINT	MSINT
KBDIC	0x08	SFOFF						EVTIC	KBDIC
KBDMASK	0x09					MSKELINT	MSKEINT	MSKLINT	MSKSINT
KBDCODE0	0x0B	MULTIKEY	KEYROW2	KEYROW1	KEYROW0	KEYCOL3	KEYCOL2	KEYCOL1	KEYCOL0
KBDCODE1	0x0C	MULTIKEY	KEYROW2	KEYROW1	KEYROW0	KEYCOL3	KEYCOL2	KEYCOL1	KEYCOL0
KBDCODE2	0x0D	MULTIKEY	KEYROW2	KEYROW1	KEYROW0	KEYCOL3	KEYCOL2	KEYCOL1	KEYCOL0
KBDCODE3	0x0E	MULTIKEY	KEYROW2	KEYROW1	KEYROW0	KEYCOL3	KEYCOL2	KEYCOL1	KEYCOL0
EVTCODE	0x10	RELEASE	KEYROW2	KEYROW1	KEYROW0	KEYCOL3	KEYCOL2	KEYCOL1	KEYCOL0
TIMCFG0	0x60				CYCIRQ0MSK				START
PWMCFG0	0x61					CDIRQ0MSK	PGE	PWMEN	PWMPOL
SCAL[7:0]									
TIMSCAL0	0x62								
TIMCFG1	0x68				CYCIRQ1MSK				START
PWMCFG1	0x69					CDIRQ1MSK	PGE	PWMEN	PWMPOL
SCAL[7:0]									
TIMSCAL1	0x6A								
TIMCFG2	0x70				CYCIRQ2MSK				START
PWMCFG2	0x71					CDIRQ2MSK	PGE	PWMEN	PWMPOL
SCAL[7:0]									
TIMSCAL2	0x72								
TIMSWRES	0x78						SWRES2	SWRES1	SWRES0
TIMRIS	0x7A			CDIRQ2	CDIRQ1	CDIRQ0	CYCIRQ2	CYCIRQ1	CYCIRQ0
TIMMIS	0x7B			CDIRQ2	CDIRQ1	CDIRQ0	CYCIRQ2	CYCIRQ1	CYCIRQ0
TIMIC	0x7C			CDIRQ2	CDIRQ1	CDIRQ0	CYCIRQ2	CYCIRQ1	CYCIRQ0
PWMWP	0x7D	0							
PWWMP[6:0]									
PWMCFG(Low)	0x7E								
CMD[7:0]									
PWMCFG(High)	0x7F								
CMD[15:8]									
I2CSA	0x80					SLAVEADDR[7:1]			0
MFGCODE	0x80							MFGBIT[7:0]	
SWREV	0x81							SWBIT[7:0]	
SWRESET	0x81							SWBIT[7:0]	

Register	Addr.	BIT 7	BIT 6	BIT 5	BIT 4	BIT 3	BIT 2	BIT 1	BIT 0
RSTCTRL	0x82				IRQRST	TIMRST		KBDRST	GPIRST
RSTINTCLR	0x84								IRQCLR
CLKMODE	0x88							MODCTL[1:0]	
CLKCFG	0x89		CLKSRCSEL[1:0]						
CLKEN	0x8A	CLKOUTEN[1:0]					TIMEN	DKBDEN	KBDEN
AUTOSLP	0x8B								ENABLE
AUTOSLPTI (Low)	0x8C								
AUTOSLPTI (High)	0x8D								
IRQST	0x91	PORIRQ	KBD1RQ	DKBDIRQ		TIM2IRQ	TIM1IRQ	TIM0IRQ	GPIIRQ
IOCFG	0xA7								
IOPC0 (Low)	0xAA	KPX3PR[1:0]		KPX2PR[1:0]		KPX1PR[1:0]			KPX0PR[1:0]
IOPC0 (High)	0xAB	KPX7PR[1:0]		KPX6PR[1:0]		KPX5PR[1:0]			KPX4PR[1:0]
IOPC1 (Low)	0xAC	KPY3PR[1:0]		KPY2PR[1:0]		KPY1PR[1:0]			KPY0PR[1:0]
IOPC1 (High)	0xAD	KPY7PR[1:0]		KPY6PR[1:0]		KPY5PR[1:0]			KPY4PR[1:0]
IOPC2 (Low)	0xAE	KPY11PR[1:0]		KPY10PR[1:0]		KPY9PR[1:0]			KPY8PR[1:0]
IOPC2 (High)	0xAF	EXTIOPR[1:0]		PWM2PR[1:0]		PWM1PR[1:0]			PWM0PR[1:0]
GPIODATA0	0xC0	DATA7	DATA6	DATA5	DATA4	DATA3	DATA2	DATA1	DATA0
GPIONMASK0	0xC1	MASK7	MASK6	MASK5	MASK4	MASK3	MASK2	MASK1	MASK0
GPIODATA1	0xC2	DATA15	DATA14	DATA13	DATA12	DATA11	DATA10	DATA9	DATA8
GPIONMASK1	0xC3	MASK15	MASK14	MASK13	MASK12	MASK11	DATA10	DATA9	DATA8
GPIODATA2	0xC4	DATA23	DATA22	DATA21	DATA20	DATA19	DATA18	DATA17	DATA16
GPIONMASK2	0xC5	MASK23	MASK22	MASK21	MASK20	MASK19	MASK18	MASK17	MASK16
GPIODIR0	0xC6	KPX7DIR	KPX6DIR	KPX5DIR	KPX4DIR	KPX3DIR	KPX2DIR	KPX1DIR	KPX0DIR
GPIODIR1	0xC7	KPY7DIR	KPY6DIR	KPY5DIR	KPY4DIR	KPY3DIR	KPY2DIR	KPY1DIR	KPY0DIR
GPIODIR2	0xC8	EXTIODIR	PWM2DIR	PWM1DIR	PWM0DIR	KP11DIR	KPY10DIR	KPY9DIR	KPY8DIR
GPIOIS0	0xC9	KPX7IS	KPX6IS	KPX5IS	KPX4IS	KPX3IS	KPX2IS	KPX1IS	KPX0IS
GPIOIS1	0xCA	KPY7IS	KPY6IS	KPY5IS	KPY4IS	KPY3IS	KPY2IS	KPY1IS	KPY0IS
GPIOIS2	0xCB	EXTIOIS	PWM2IS	PWM1IS	PWM0IS	KPY11IS	KPY10IS	KPY9IS	KPY8IS
GPIOIBE0	0xCC	KPX7IBE	KPX6IBE	KPX5IBE	KPX4IBE	KPX3IBE	KPX2IBE	KPX1IBE	KPX0IBE
GPIOIBE1	0xCD	KPY7IBE	KPY6IBE	KPY5IBE	KPY4IBE	KPY3IBE	KPY2IBE	KPY1IBE	KPY0IBE
GPIOIBE2	0xCE	EXTIOIBE	PWM2IBE	PWM1IBE	PWM0IBE	KPY11IBE	KPY10IBE	KPY9IBE	KPY8IBE
GPIOIEV0	0xCF	KPX7EV	KPX6EV	KPX5EV	KPX4EV	KPX3EV	KPX2EV	KPX1EV	KPX0EV
GPIOIEV1	0xD0	KPY7EV	KPY6EV	KPY5EV	KPY4EV	KPY3EV	KPY2EV	KPY1EV	KPY0EV
GPIOIEV2	0xD1	EXTIOIEV	PWM2IEV	PWM1IEV	PWM0IEV	KPY11IEV	KPY10IEV	KPY9IEV	KPY8IEV
GPIOIE0	0xD2	KPX7IE	KPX6IE	KPX5IE	KPX4IE	KPX3IE	KPX2IE	KPX1IE	KPX0IE

Register	Addr.	BIT 7	BIT 6	BIT 5	BIT 4	BIT 3	BIT 2	BIT 1	BIT 0
GPIOIE1	0xD3	KPY7IE	KPY6IE	KPY5IE	KPY4IE	KPY3IE	KPY2IE	KPY1IE	KPY0IE
GPIOIE2	0xD4	EXTIOIE	PWM2IE	PWM1IE	PWM0IE	KPY11IE	KPY10IE	KPY9IE	KPY8IE
GPIOIRIS0	0xD6	KPX7RIS	KPX6RIS	KPX5RIS	KPX4RIS	KPX3RIS	KPX2RIS	KPX1RIS	KPX0RIS
GPIOIRIS1	0xD7	KPY7RIS	KPY6RIS	KPY5RIS	KPY4RIS	KPY3RIS	KPY2RIS	KPY1RIS	KPY0RIS
GPIOIRIS2	0xD8	EXTIORIS	PWM2RIS	PWM1RIS	PWM0RIS	KPY11RIS	KPY10RIS	KPY9RIS	KPY8RIS
GPIOIMS0	0xD9	KPX7MIS	KPX6MIS	KPX5MIS	KPX4MIS	KPX3MIS	KPX2MIS	KPX1MIS	KPX0MIS
GPIOIMS1	0xDA	KPY7MIS	KPY6MIS	KPY5MIS	KPY4MIS	KPY3MIS	KPY2MIS	KPY1MIS	KPY0MIS
GPIOIMS2	0xDB	EXTIOMIS	PWM2MIS	PWM1MIS	PWM0MIS	KPY11MIS	KPY10MIS	KPY9MIS	KPY8MIS
GPIOIC0	0xDC	KPX7IC	KPX6IC	KPX5IC	KPX4IC	KPX3IC	KPX2IC	KPX1IC	KPX0IC
GPIOIC1	0xDD	KPY7IC	KPY6IC	KPY5IC	KPY4IC	KPY3IC	KPY2IC	KPY1IC	KPY0IC
GPIOIC2	0xDE	EXTIOIC	PWM2IC	PWM1IC	PWM0IC	KPY11IC	KPY10IC	KPY9IC	KPY8IC
GPIOOME0	0xE0	KPX7ODE	KPX6ODE	KPX5ODE	KPX4ODE	KPX3ODE	KPX2ODE	KPX1ODE	KPX0ODE
GPIOOMS0	0xE1	KPX7ODM	KPX6ODM	KPX5ODM	KPX4ODM	KPX3ODM	KPX2ODM	KPX1ODM	KPX0ODM
GPIOOME1	0xE2	KPY7ODE	KPY6ODE	KPY5ODE	KPY4ODE	KPY3ODE	KPY2ODE	KPY1ODE	KPY0ODE
GPIOOMS1	0xE3	KPY7ODM	KPY6ODM	KPY5ODM	KPY4ODM	KPY3ODM	KPY2ODM	KPY1ODM	KPY0ODM
GPIOOME2	0xE4	EXTIO-ODE	PWM2-ODE	PWM1-ODE	PWM0-ODE	KPY11ODE	KPY10ODE	KPY9 ODE	KPY8 ODE
GPIOOMS2	0xE5	EXTIO-ODM	PWM2-ODM	PWM1-ODM	PWM0-ODM	KPY11ODM	KPY10ODM	KPY9 ODM	KPY8 ODM
DEVTCODE	0xE6					DKEYCODE[4:0]			
DBOUNCE	0xE7					DBOUNCE[4:0]			
GPIOWAKE0	0xE9	KPX7WAKE	KPX6WAKE	KPX5WAKE	KPX4WAKE	KPX3WAKE	KPX2WAKE	KPX1WAKE	KPX0WAKE
GPIOWAKE1	0xEA	KPY7WAKE	KPY6WAKE	KPY5WAKE	KPY4WAKE	KPY3WAKE	KPY2WAKE	KPY1WAKE	KPY0WAKE
GPIOWAKE2	0xEB	EXTIOWAKE	PWM2WAKE	PWM1WAKE	PWM0WAKE	KPY11WAKE	KPY10WAKE	KPY9WAKE	KPY8WAKE
DIRECT0	0xEC	DK07	DK06	DK05	DK04	DK03	DK02	DK01	DK00
DIRECT1	0xED	DK15	DK14	DK13	DK12	DK11	DK10	DK09	DK08
DIRECT2	0xEE	DK23	DK22	DK21	DK20	DK19	DK18	DK17	DK16
DIRECT3	0xEF							DK25	DK24
DKBDRIS	0xF0							DRELINT	DREVTINT
DKBDMIS	0xF1							DMELINT	DMEVTINT
DKBDIC	0xF2								DEVTIC
DKBDMASK	0xF3							DMSKELINT	DMSKEINT
MMMASTER	0xF4				MSTADR[7:1]				MMSTEN

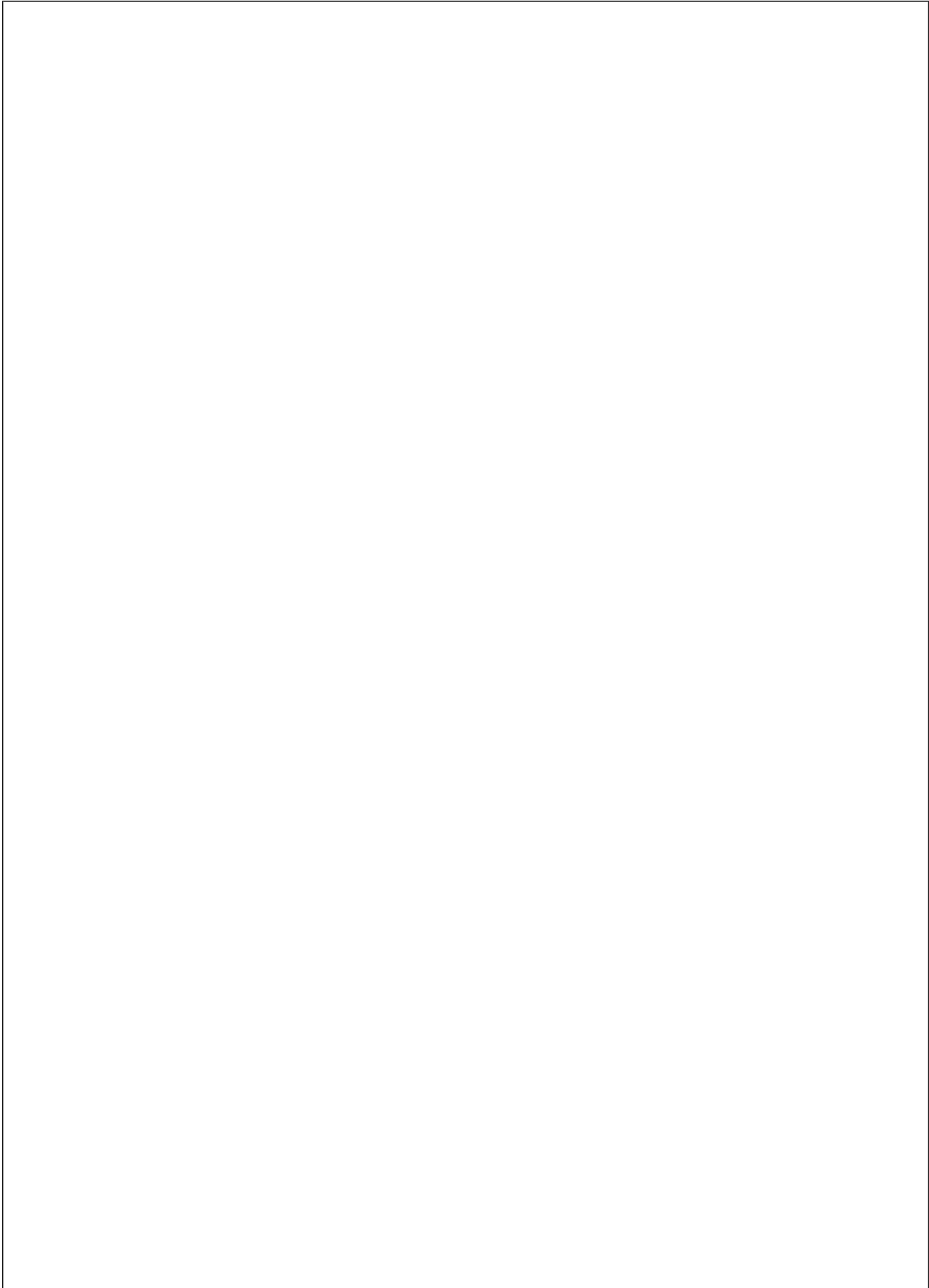

18.0 Physical Dimensions inches (millimeters) unless otherwise noted

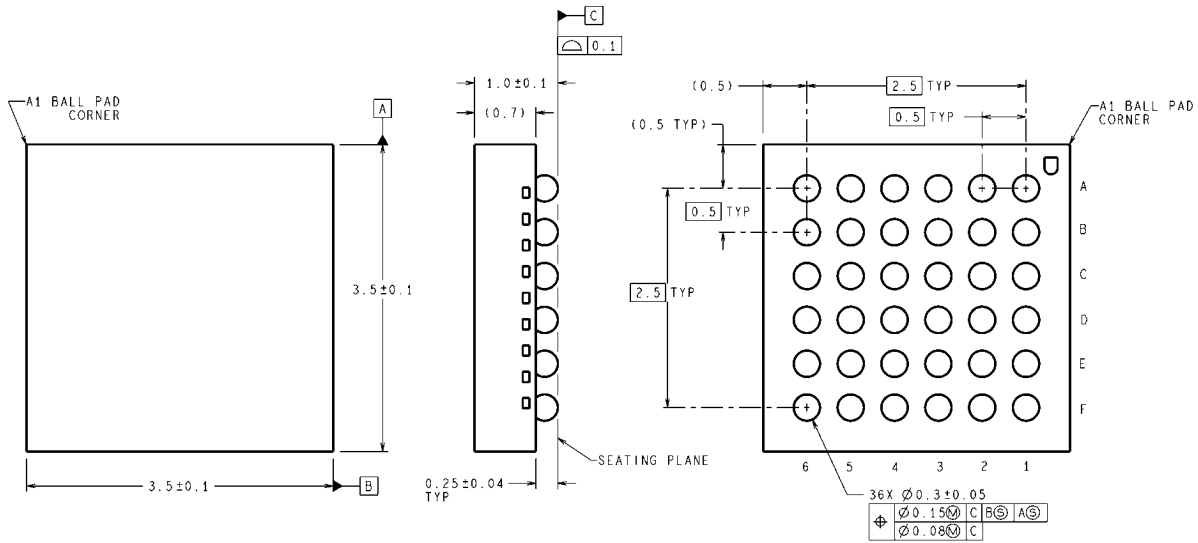

DIMENSIONS ARE IN MILLIMETERS
DIMENSIONS IN () FOR REFERENCE ONLY

GRA36A (Rev A)

MICRO ARRAY Package
Order Number LM8327JGR8 NOPB or LM8327JGR8X NOPB
NS Package Number GRA36A

Notes

For more National Semiconductor product information and proven design tools, visit the following Web sites at:
www.national.com

Products		Design Support	
Amplifiers	www.national.com/amplifiers	WEBENCH® Tools	www.national.com/webench
Audio	www.national.com/audio	App Notes	www.national.com/appnotes
Clock and Timing	www.national.com/timing	Reference Designs	www.national.com/refdesigns
Data Converters	www.national.com/adc	Samples	www.national.com/samples
Interface	www.national.com/interface	Eval Boards	www.national.com/evalboards
LVDS	www.national.com/lvds	Packaging	www.national.com/packaging
Power Management	www.national.com/power	Green Compliance	www.national.com/quality/green
Switching Regulators	www.national.com/switchers	Distributors	www.national.com/contacts
LDOs	www.national.com/ldo	Quality and Reliability	www.national.com/quality
LED Lighting	www.national.com/led	Feedback/Support	www.national.com/feedback
Voltage References	www.national.com/vref	Design Made Easy	www.national.com/easy
PowerWise® Solutions	www.national.com/powerwise	Applications & Markets	www.national.com/solutions
Serial Digital Interface (SDI)	www.national.com/sdi	Mil/Aero	www.national.com/milaero
Temperature Sensors	www.national.com/tempensors	SolarMagic™	www.national.com/solarmagic
PLL/VCO	www.national.com/wireless	PowerWise® Design University	www.national.com/training

THE CONTENTS OF THIS DOCUMENT ARE PROVIDED IN CONNECTION WITH NATIONAL SEMICONDUCTOR CORPORATION ("NATIONAL") PRODUCTS. NATIONAL MAKES NO REPRESENTATIONS OR WARRANTIES WITH RESPECT TO THE ACCURACY OR COMPLETENESS OF THE CONTENTS OF THIS PUBLICATION AND RESERVES THE RIGHT TO MAKE CHANGES TO SPECIFICATIONS AND PRODUCT DESCRIPTIONS AT ANY TIME WITHOUT NOTICE. NO LICENSE, WHETHER EXPRESS, IMPLIED, ARISING BY ESTOPPEL OR OTHERWISE, TO ANY INTELLECTUAL PROPERTY RIGHTS IS GRANTED BY THIS DOCUMENT.

TESTING AND OTHER QUALITY CONTROLS ARE USED TO THE EXTENT NATIONAL DEEMS NECESSARY TO SUPPORT NATIONAL'S PRODUCT WARRANTY. EXCEPT WHERE MANDATED BY GOVERNMENT REQUIREMENTS, TESTING OF ALL PARAMETERS OF EACH PRODUCT IS NOT NECESSARILY PERFORMED. NATIONAL ASSUMES NO LIABILITY FOR APPLICATIONS ASSISTANCE OR BUYER PRODUCT DESIGN. BUYERS ARE RESPONSIBLE FOR THEIR PRODUCTS AND APPLICATIONS USING NATIONAL COMPONENTS. PRIOR TO USING OR DISTRIBUTING ANY PRODUCTS THAT INCLUDE NATIONAL COMPONENTS, BUYERS SHOULD PROVIDE ADEQUATE DESIGN, TESTING AND OPERATING SAFEGUARDS.

EXCEPT AS PROVIDED IN NATIONAL'S TERMS AND CONDITIONS OF SALE FOR SUCH PRODUCTS, NATIONAL ASSUMES NO LIABILITY WHATSOEVER, AND NATIONAL DISCLAIMS ANY EXPRESS OR IMPLIED WARRANTY RELATING TO THE SALE AND/OR USE OF NATIONAL PRODUCTS INCLUDING LIABILITY OR WARRANTIES RELATING TO FITNESS FOR A PARTICULAR PURPOSE, MERCHANTABILITY, OR INFRINGEMENT OF ANY PATENT, COPYRIGHT OR OTHER INTELLECTUAL PROPERTY RIGHT.

LIFE SUPPORT POLICY

NATIONAL'S PRODUCTS ARE NOT AUTHORIZED FOR USE AS CRITICAL COMPONENTS IN LIFE SUPPORT DEVICES OR SYSTEMS WITHOUT THE EXPRESS PRIOR WRITTEN APPROVAL OF THE CHIEF EXECUTIVE OFFICER AND GENERAL COUNSEL OF NATIONAL SEMICONDUCTOR CORPORATION. As used herein:

Life support devices or systems are devices which (a) are intended for surgical implant into the body, or (b) support or sustain life and whose failure to perform when properly used in accordance with instructions for use provided in the labeling can be reasonably expected to result in a significant injury to the user. A critical component is any component in a life support device or system whose failure to perform can be reasonably expected to cause the failure of the life support device or system or to affect its safety or effectiveness.

National Semiconductor and the National Semiconductor logo are registered trademarks of National Semiconductor Corporation. All other brand or product names may be trademarks or registered trademarks of their respective holders.

Copyright© 2011 National Semiconductor Corporation

For the most current product information visit us at www.national.com



National Semiconductor Americas Technical Support Center
 Email: support@nsc.com
 Tel: 1-800-272-9959

National Semiconductor Europe Technical Support Center
 Email: europe.support@nsc.com

National Semiconductor Asia Pacific Technical Support Center
 Email: ap.support@nsc.com

National Semiconductor Japan Technical Support Center
 Email: jpn.feedback@nsc.com

IMPORTANT NOTICE

Texas Instruments Incorporated and its subsidiaries (TI) reserve the right to make corrections, modifications, enhancements, improvements, and other changes to its products and services at any time and to discontinue any product or service without notice. Customers should obtain the latest relevant information before placing orders and should verify that such information is current and complete. All products are sold subject to TI's terms and conditions of sale supplied at the time of order acknowledgment.

TI warrants performance of its hardware products to the specifications applicable at the time of sale in accordance with TI's standard warranty. Testing and other quality control techniques are used to the extent TI deems necessary to support this warranty. Except where mandated by government requirements, testing of all parameters of each product is not necessarily performed.

TI assumes no liability for applications assistance or customer product design. Customers are responsible for their products and applications using TI components. To minimize the risks associated with customer products and applications, customers should provide adequate design and operating safeguards.

TI does not warrant or represent that any license, either express or implied, is granted under any TI patent right, copyright, mask work right, or other TI intellectual property right relating to any combination, machine, or process in which TI products or services are used. Information published by TI regarding third-party products or services does not constitute a license from TI to use such products or services or a warranty or endorsement thereof. Use of such information may require a license from a third party under the patents or other intellectual property of the third party, or a license from TI under the patents or other intellectual property of TI.

Reproduction of TI information in TI data books or data sheets is permissible only if reproduction is without alteration and is accompanied by all associated warranties, conditions, limitations, and notices. Reproduction of this information with alteration is an unfair and deceptive business practice. TI is not responsible or liable for such altered documentation. Information of third parties may be subject to additional restrictions.

Resale of TI products or services with statements different from or beyond the parameters stated by TI for that product or service voids all express and any implied warranties for the associated TI product or service and is an unfair and deceptive business practice. TI is not responsible or liable for any such statements.

TI products are not authorized for use in safety-critical applications (such as life support) where a failure of the TI product would reasonably be expected to cause severe personal injury or death, unless officers of the parties have executed an agreement specifically governing such use. Buyers represent that they have all necessary expertise in the safety and regulatory ramifications of their applications, and acknowledge and agree that they are solely responsible for all legal, regulatory and safety-related requirements concerning their products and any use of TI products in such safety-critical applications, notwithstanding any applications-related information or support that may be provided by TI. Further, Buyers must fully indemnify TI and its representatives against any damages arising out of the use of TI products in such safety-critical applications.

TI products are neither designed nor intended for use in military/aerospace applications or environments unless the TI products are specifically designated by TI as military-grade or "enhanced plastic." Only products designated by TI as military-grade meet military specifications. Buyers acknowledge and agree that any such use of TI products which TI has not designated as military-grade is solely at the Buyer's risk, and that they are solely responsible for compliance with all legal and regulatory requirements in connection with such use.

TI products are neither designed nor intended for use in automotive applications or environments unless the specific TI products are designated by TI as compliant with ISO/TS 16949 requirements. Buyers acknowledge and agree that, if they use any non-designated products in automotive applications, TI will not be responsible for any failure to meet such requirements.

Following are URLs where you can obtain information on other Texas Instruments products and application solutions:

Products

Audio	www.ti.com/audio
Amplifiers	amplifier.ti.com
Data Converters	dataconverter.ti.com
DLP® Products	www.dlp.com
DSP	dsp.ti.com
Clocks and Timers	www.ti.com/clocks
Interface	interface.ti.com
Logic	logic.ti.com
Power Mgmt	power.ti.com
Microcontrollers	microcontroller.ti.com
RFID	www.ti-rfid.com
OMAP Mobile Processors	www.ti.com/omap
Wireless Connectivity	www.ti.com/wirelessconnectivity

Applications

Communications and Telecom	www.ti.com/communications
Computers and Peripherals	www.ti.com/computers
Consumer Electronics	www.ti.com/consumer-apps
Energy and Lighting	www.ti.com/energy
Industrial	www.ti.com/industrial
Medical	www.ti.com/medical
Security	www.ti.com/security
Space, Avionics and Defense	www.ti.com/space-avionics-defense
Transportation and Automotive	www.ti.com/automotive
Video and Imaging	www.ti.com/video

TI E2E Community Home Page

e2e.ti.com

Mailing Address: Texas Instruments, Post Office Box 655303, Dallas, Texas 75265
Copyright © 2011, Texas Instruments Incorporated