



LC87F1K64A

CMOS IC

8-bit Microcontroller with USB-host Controller

64K-byte Flash ROM / 8K-byte RAM / 48-pin

ON Semiconductor®

<http://onsemi.com>

Overview

The LC87F1K64A is an 8-bit microcontroller that, integrates on a single chip a number of hardware features such as 64K-byte flash ROM, 8192-byte RAM, an on-chip debugger, a sophisticated 16-bit timer/counter (may be divided into 8-bit timers), a 16-bit timer (may be divided into 8-bit timers or PWMs), four 8-bit timers with a prescaler, a base timer serving as a time-of-day clock, two channels of synchronous SIO interface with automatic data transfer capabilities, an asynchronous/synchronous SIO interface, a single-master I²C/synchronous SIO interface, a UART interface (full duplex), a full/low-speed USB interface (host control function) × 2 ports, a 12-bit 12-channel AD converter, two channels of 12-bit PWM, a system clock frequency divider, an infrared remote control receiver circuit, an internal reset circuit, and a 44-source 10-vector interrupt feature.

Features

■Flash ROM

- 65536×8 bits
- Capable of on-board programming with a wide range of supply voltage from 3.0 to 5.5V
- Block-erasable in 128-byte units
- Data written in 2-byte units

■RAM

- 8192×9 bits

■Package Form

- SQFP48 (7×7): Lead-/halogen-free product

■Bus Cycle Time

- 83.3ns (when CF=12MHz)

Note: The bus cycle time here refers to the ROM read speed.

■Minimum Instruction Cycle Time (tCYC)

- 250ns (when CF=12MHz)

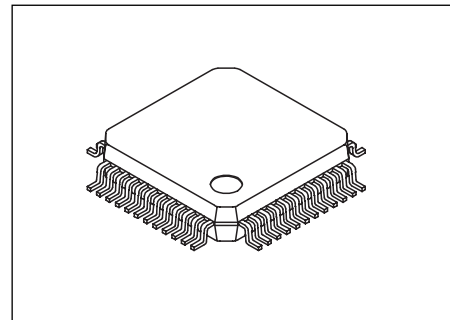

SQFP48(7X7)

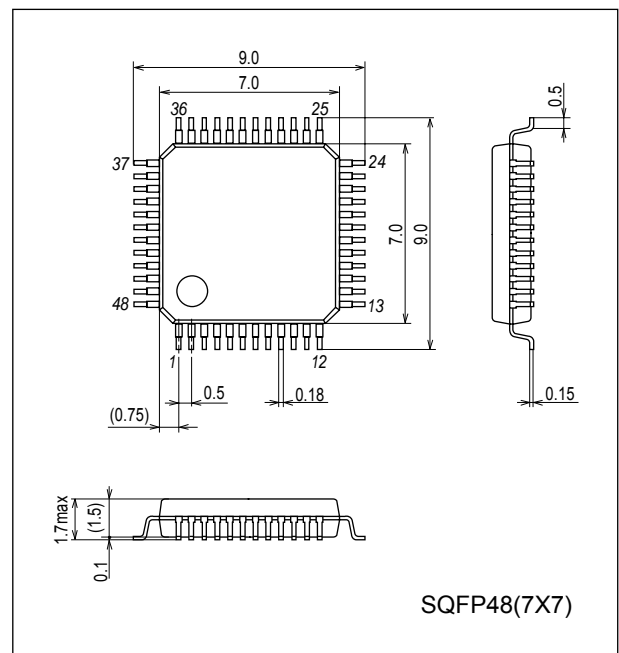

SQFP48(7X7)

ORDERING INFORMATION

See detailed ordering and shipping information on page 35 of this data sheet.

* This product is licensed from Silicon Storage Technology, Inc. (USA).

LC87F1K64A

■ Ports

- I/O ports

Ports whose input/output can be specified in 1-bit units: 34 (P00 to P07, P10 to P17, P20 to P25, P30 to P34, P70 to P73, PWM0, PWM1, XT2)

- USB ports 4 (UHAD+, UHAD-, UHBD+, UHBD-)
- Dedicated oscillator ports 2 (CF1, CF2)
- Input-only port (also used for the oscillator) 1 (XT1)
- Reset pin 1 ($\overline{\text{RES}}$)
- Power supply pins 6 (V_{SS1} to 3, V_{DD1} to 3)

■ Timers

- Timer 0: 16-bit timer/counter with 2 capture registers

Mode 0: 8-bit timer with an 8-bit programmable prescaler
(with two 8-bit capture registers) \times 2 channels

Mode 1: 8-bit timer with an 8-bit programmable prescaler
(with two 8-bit capture registers) + 8-bit counter (with two 8-bit capture registers)

Mode 2: 16-bit timer with an 8-bit programmable prescaler (with two 16-bit capture registers)

Mode 3: 16-bit counter (with two 16-bit capture registers)

- Timer 1: 16-bit timer/counter that supports PWM/toggle output

Mode 0: 8-bit timer with an 8-bit prescaler (with toggle output)
+ 8-bit timer/counter with an 8-bit prescaler (with toggle output)

Mode 1: 8-bit PWM with an 8-bit prescaler \times 2 channels

Mode 2: 16-bit timer/counter with an 8-bit prescaler (with toggle output)
(Toggle output also possible from low-order 8 bits.)

Mode 3: 16-bit timer with an 8-bit prescaler (with toggle output)
(Low-order 8 bits can be used as a PWM output.)

- Timer 4: 8-bit timer with a 6-bit prescaler

- Timer 5: 8-bit timer with a 6-bit prescaler

- Timer 6: 8-bit timer with a 6-bit prescaler (with toggle output)

- Timer 7: 8-bit timer with a 6-bit prescaler (with toggle output)

- Base timer

- 1) The clock can be selected from among a subclock (32.768kHz crystal oscillator), low-speed RC oscillator clock, system clock, and timer 0 prescaler output.
- 2) Interrupts programmable in 5 different time schemes.

■ Serial Interfaces

- SIO0: Synchronous serial interface

1) LSB first/MSB first selectable

2) Transfer clock cycle: 4/3 to 512/3 tCYC

3) Continuous automatic data transmission (1 to 256 bits can be specified in 1-bit units)
(Suspension and resumption of data transfer possible in 1-byte units)

- SIO1: 8-bit asynchronous/synchronous serial interface

Mode 0: Synchronous 8-bit serial I/O (2- or 3-wire configuration, 2 to 512 tCYC transfer clock)

Mode 1: Asynchronous serial I/O (half-duplex, 8 data bits, 1 stop bit, 8 to 2048 tCYC baudrate)

Mode 2: Bus mode 1 (start bit, 8 data bits, 2 to 512 tCYC transfer clock)

Mode 3: Bus mode 2 (start detection, 8 data bits, stop detection)

- SIO4: Synchronous serial interface

1) LSB first/MSB first selectable

2) Transfer clock cycle: 4/3 to 1020/3 tCYC

3) Continuous automatic data transmission (1 to 8192 bytes can be specified in 1-byte units)
(Suspension and resumption of data transmission possible in 1-byte units or in word units)

4) Clock polarity can be selected.

5) CRC16 calculator circuit built-in

- SMIIC0: Single-master I²C/8-bit synchronous SIO

Mode 0: Communication in single-master mode.

Mode 1: 8-bit synchronous serial I/O (data MSB first)

■ Full Duplex UART

- 1) Data length: 7/8/9 bits selectable
- 2) Stop bits: 1 bit (2 bits in continuous transmission mode)
- 3) Parity bits: None/even/odd selectable (for 8-bit data only)
- 4) Baudrate: 16/3 to 8192/3 tCYC

■ AD Converter: 12 bits × 12 channels

■ PWM: Variable frequency 12-bit PWM × 2 channels

■ Infrared Remote Control Receiver Circuit

- 1) Noise rejection function (noise filter time constant: Approx. 120μs when the 32.768kHz crystal oscillator is selected as the reference clock)
- 2) Supports data encoding systems such as PPM (Pulse Position Modulation) and Manchester encoding.
- 3) X'tal HOLD mode release function

■ USB Interface (host control function) × 2 ports

- 1) Supports full-speed (12Mbps) and low-speed (1.5Mbps) specifications.
- 2) Supports four transfer types (control transfer, bulk transfer, interrupt transfer, and isochronous transfer).

■ Audio Interface

- 1) Sampling frequencies (fs): 8kHz/11.025kHz/12kHz/16kHz/22.05kHz/24kHz/32kHz/44.1kHz/48kHz
- 2) Master clock: 256fs/384fs
- 3) Bit clock: 48fs/64fs
- 4) Data bit length: 16bits/18bits/20bits/24bits
- 5) LSB first/MSB first selectable.
- 6) Left justified/right justified/I2S format selectable

■ Watchdog Timer

- External RC time constant type
 - 1) Interrupt generation/reset generation selectable
 - 2) Operation in HALT/HOLD mode can be selected from “continue operation” and “suspend operation.”
- Internal timer type
 - 1) Capable of generating a internal reset signal on an overflow of the timer running on the low-speed RC oscillator clock, or subclock.
 - 2) Operation in HALT/HOLD mode can be selected from among “continue count operation,” “suspend operation,” and “retain the count value.”

■ Clock Output Function

- 1) Can output a clock with a clock rate of 1/1, 1/2, 1/4, 1/8, 1/16, 1/32, or 1/64 of the source oscillator clock selected as the system clock.
- 2) Can output the source oscillator clock for the subclock.

■ Interrupts

- 44 sources, 10 vectors

- 1) Provides three levels (low (L), high (H), and highest (X)) of multiplex interrupt control. Any interrupt request of the level equal to or lower than the current interrupt level is not accepted.
- 2) When interrupt requests to two or more vector addresses occur at the same time, the interrupt of the highest level takes precedence over the other interrupts. For interrupts of the same level, the interrupt into the lowest vector address is given priority.

No.	Vector	Level	Interrupt Source
1	00003H	X or L	INT0
2	0000BH	X or L	INT1
3	00013H	H or L	INT2/T0L/INT4/UHC-A bus active/UHC-B bus active/remote control receive
4	0001BH	H or L	INT3/INT5/base timer
5	00023H	H or L	T0H/INT6/UHC-A device connected, disconnected, resumed
6	0002BH	H or L	T1L/T1H/INT7/AIF start/SMIIC0/UHC-B device connected, disconnected, resumed
7	00033H	H or L	SIO0/UART1 reception completed
8	0003BH	H or L	SIO1/SIO4/UART1 buffer empty/UART1 transmission completed/AIF end
9	00043H	H or L	ADC/T6/T7/UHC-ACK/UHC-NAK/UHC error/UHC-STALL
10	0004BH	H or L	Port 0/PWM0/PWM1/T4/T5/UHC-SOF

- Priority levels $X > H > L$
- When interrupts of the same level occur at the same time, the interrupt with the lowest vector address is given priority.

■ Subroutine Stack Levels: Up to 4096 levels (The stack is allocated in RAM.)

■ High-speed Multiplication/Division Instructions

- 16 bits \times 8 bits (5 tCYC execution time)
- 24 bits \times 16 bits (12 tCYC execution time)
- 16 bits \div 8 bits (8 tCYC execution time)
- 24 bits \div 16 bits (12 tCYC execution time)

■ Oscillator Circuit and PLL

- Medium-speed RC oscillator circuit (internal): For system clock (approx. 1MHz)
- Low-speed RC oscillator circuit (internal): For system clock, timer, and watchdog timer (approx. 30kHz)
- CF oscillator circuit: For system clock
- Crystal oscillator circuit: For system clock and time-of-day clock
- PLL circuit (internal): For USB interface (see Fig. 5) and audio interface (see Fig. 6)

■ Internal Reset Functions

- Power-on reset (POR) function
 - 1) POR is activated at power-on.
 - 2) POR release voltage can be selected from 8 levels (1.67V, 1.97V, 2.07V, 2.37V, 2.57V, 2.87V, 3.86V, and 4.35V) by setting options.
- Low voltage detection reset (LVD) function
 - 1) LVD and POR functions are combined to generate resets when power is turned on and when power voltage falls below a threshold level.
 - 2) The use/disuse of the LVD function and the low voltage threshold level (7 levels: 1.91V, 2.01V, 2.31V, 2.51V, 2.81V, 3.79V, and 4.28V) can be selected by setting options.

LC87F1K64A

■ Standby Function

- HALT mode: Halts instruction execution while allowing the peripheral circuits to continue operation.
 - 1) Oscillators do not stop automatically.
 - 2) There are three ways of releasing HOLD mode.
 - (1) Setting the reset pin to a low level.
 - (2) Generating a reset signal by watchdog timer or low-voltage detection
 - (3) Occurrence of an interrupt
- HOLD mode: Suspends instruction execution and operation of the peripheral circuits.
 - 1) The PLL, CF, RC and crystal oscillators automatically stop operation.

Note: Low-speed RC oscillator is controlled directly by the watchdog timer and its oscillation in standby mode is also controlled.
 - 2) There are five ways of releasing HOLD mode.
 - (1) Setting the reset pin to a low level
 - (2) Generating a reset signal by the watchdog timer or low-voltage detection
 - (3) Establishing an interrupt source at one of INT0, INT1, INT2, INT4, and INT5 pins
* INT0 and INT1 HOLD mode release is available only when level detection is configured.
 - (4) Establishing an interrupt source at port 0
 - (5) Establishing an bus active interrupt source in the USB host control circuit
- X'tal HOLD mode: Suspends instruction execution and the operation of the peripheral circuits except the base timer and infrared remote control receiver circuit.
 - 1) The PLL, CF and RC oscillators automatically stop operation.

Note: Low-speed RC oscillator is controlled directly by the watchdog timer and its oscillation in standby mode is also controlled.

Note: The low-speed RC oscillator retains the state that is established on entry into X'tal HOLD mode if the base timer is running with the low-speed RC oscillator selected as the base timer input clock source.
 - 2) The state of crystal oscillator established when the X'tal HOLD mode is entered is retained.
 - 3) There are seven ways of releasing X'tal HOLD mode.
 - (1) Setting the reset pin to a low level
 - (2) Generating a reset signal by the watchdog timer or low-voltage detection
 - (3) Establishing an interrupt source at one of INT0, INT1, INT2, INT4, and INT5 pins
* INT0 and INT1 X'tal HOLD mode release is available only when level detection is configured.
 - (4) Establishing an interrupt source at port 0
 - (5) Establishing an interrupt source in the base timer circuit
 - (6) Establishing an interrupt source in the infrared remote control receiver circuit
 - (7) Establishing an bus active interrupt source in the USB host control circuit

■ Development Tools

- On-chip debugger: TCB87–Type B + LC87F1K64A or
TCB87–Type C (3-wire communication cable) + LC87F1K64A

■ Flash ROM Programming Board

Package	Programming Board
SQFP48 (7×7)	W87F55256SQ

LC87F1K64A

Flash ROM Programmer

Maker		Model	Supported Version	Device
Flash Support Group Company (FSG)	Single	AF9709C	Rev.03.32 and later	87F064JU
Flash Support Group Company (FSG) + Our company (Note 1)	Onboard single/ganged	AF9101/AF9103 (main unit) (FSG model)	(Note 2)	LC87F1K64A
		SIB87 Type C (interface driver) (Our company model)		
Our company	Single/ganged	SKK/SKK Type C (SANYO FWS)	Application version 1.07 and later Chip data version 2.39 and later	LC87F1K64
	Onboard single/ganged	SKK-DBG Type C (SANYO FWS)		

(Further information on the AF series)

Flash Support Group Company (TOA ELECTRONICS, Inc.)

Phone: 053-459-1050

E-mail: sales@j-fsg.co.jp

Note 1: PC-less standalone onboard programming is possible using the FSG onboard programmer (AF9101/AF9103) and the serial interface driver (SIB87 Type C) provided by Our company in pair.

Note 2: Dedicated programming device and program are required depending on the programming conditions. Contact Our company or FSG if you have any questions or difficulties regarding this matter.

LC87F1K64A

SQFP48	NAME
1	P73/INT3/T0IN/RMIN
2	RES
3	XT1/AN10
4	XT2/AN11
5	V _{SS} 1
6	CF1
7	CF2
8	V _{DD} 1
9	P10/SO0
10	P11/SI0/SB0
11	P12/SCK0
12	P13/SO1/SM0CK1
13	P14/SI1/SB1/SM0DA1
14	P15/SCK1/SM0DO
15	P16/T1PWML/SM0DA0
16	P17/T1PWMH/BUZ/SM0CK0
17	PWM1/MCLKI
18	PWM0/MCLKO
19	V _{DD} 2
20	V _{SS} 2
21	P00/AN0
22	P01/AN1
23	P02/AN2/DBGP0
24	P03/AN3/DBGP1

SQFP48	NAME
25	P04/AN4/DBGP2
26	P05/AN5/CKO/SDAT
27	P06/AN6/T6O/BCLK
28	P07/AN7/T7O/LRCK
29	P20/INT4/INT6
30	P21/INT4
31	P22/INT4/SO4
32	P23/INT4/SI4
33	P24/INT5/INT7/SCK4
34	P25/INT5
35	UHBD-
36	UHBD+
37	UHAD-
38	UHAD+
39	V _{DD} 3
40	V _{SS} 3
41	P34/UFILT
42	P33/AFILT
43	P32
44	P31/URX1
45	P30/UTX1
46	P70/INT0/T0LCP/AN8
47	P71/INT1/T0HCP/AN9
48	P72/INT2/T0IN

LC87F1K64A

System Block Diagram

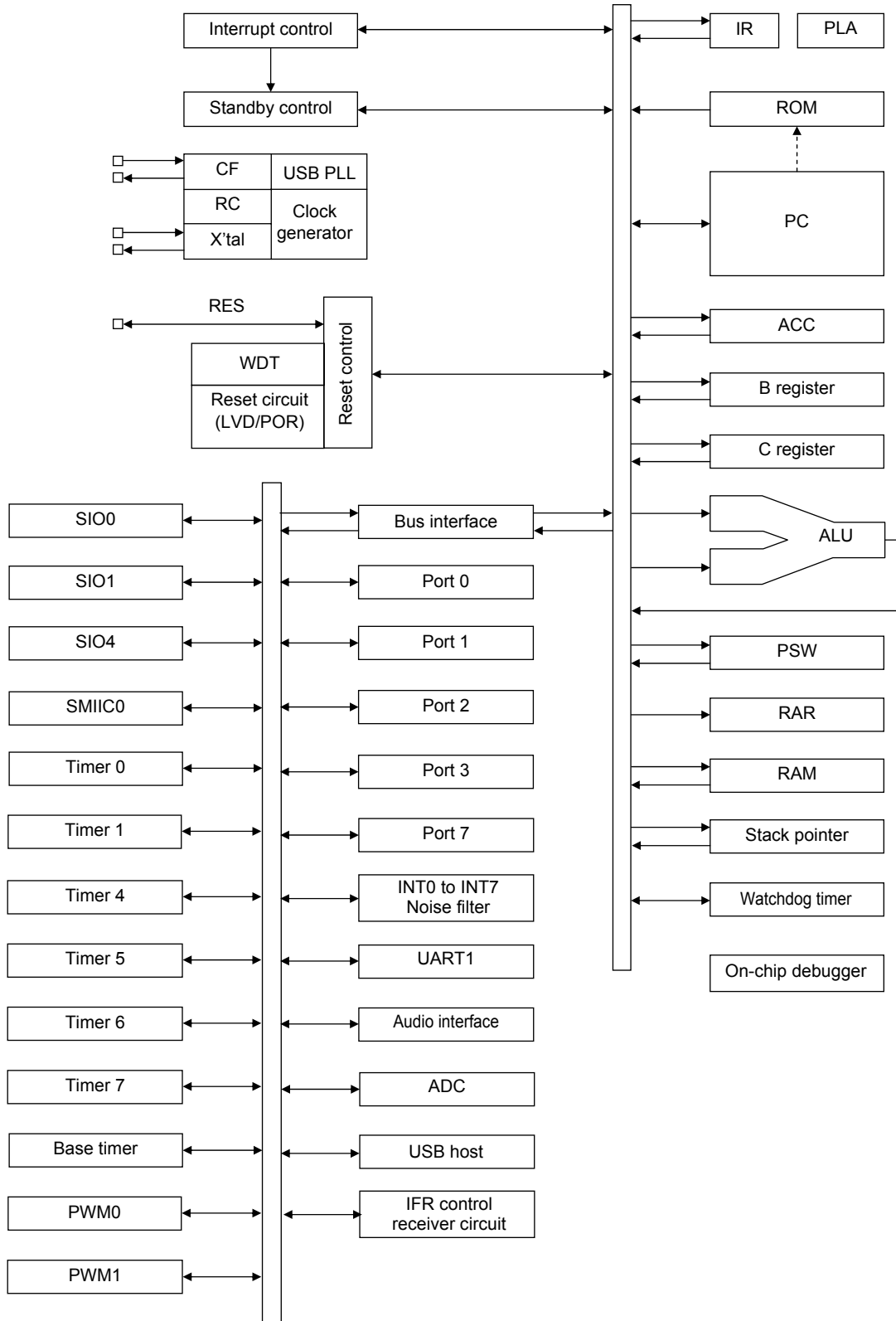

LC87F1K64A

Pin Description

Pin Name	I/O	Description	Option																														
V _{SS1} , V _{SS2} , V _{SS3}	-	-power supply	No																														
V _{DD1} , V _{DD2}	-	+power supply	No																														
V _{DD3}	-	USB reference voltage	Yes																														
Port 0 P00 to P07	I/O	<ul style="list-style-type: none"> 8-bit I/O port I/O can be specified in 1-bit units Pull-up resistors can be turned on and off in 1-bit units. HOLD release input Port 0 interrupt input Pin functions <ul style="list-style-type: none"> AD converter input port: AN0 to AN7 (P00 to P07) On-chip debugger pins: DBG P0 to DBG P2 (P02 to P04) P05: System clock output / audio interface SDAT I/O P06: Timer 6 toggle output / audio interface BCLK I/O P07: Timer 7 toggle output / audio interface LRCK I/O 	Yes																														
Port 1 P10 to P17	I/O	<ul style="list-style-type: none"> 8-bit I/O port I/O can be specified in 1-bit units Pull-up resistors can be turned on and off in 1-bit units. Pin functions <ul style="list-style-type: none"> P10: SIO0 data output P11: SIO0 data input / bus I/O P12: SIO0 clock I/O P13: SIO1 data output / SMIIC0 clock I/O P14: SIO1 data input / bus I/O / SMIIC0 bus I/O / data input P15: SIO1 clock I/O / SMIIC0 data output (used in 3-wire SIO mode) P16: Timer 1 PWML output / SMIIC0 bus I/O / data input P17: Timer 1 PWMH output / buzzer output / SMIIC0 clock I/O 	Yes																														
Port 2 P20 to P25	I/O	<ul style="list-style-type: none"> 6-bit I/O port I/O can be specified in 1-bit units Pull-up resistors can be turned on and off in 1-bit units. Pin functions <ul style="list-style-type: none"> P20 to P23: INT4 input / HOLD release input / timer 1 event input / timer 0L capture input / timer 0H capture input P24 to P25: INT5 input / HOLD release input / timer 1 event input / timer 0L capture input / timer 0H capture input P20: INT6 input / timer 0L capture 1 input P22: SIO4 data I/O P23: SIO4 data I/O P24: INT7 input / timer 0H capture 1 input / SIO4 clock I/O Interrupt acknowledge types <table border="1" style="margin-left: 20px;"> <thead> <tr> <th></th> <th>Rising</th> <th>Falling</th> <th>Rising & Falling</th> <th>H Level</th> <th>L Level</th> </tr> </thead> <tbody> <tr> <td>INT4</td> <td>Enable</td> <td>Enable</td> <td>Enable</td> <td>Disable</td> <td>Disable</td> </tr> <tr> <td>INT5</td> <td>Enable</td> <td>Enable</td> <td>Enable</td> <td>Disable</td> <td>Disable</td> </tr> <tr> <td>INT6</td> <td>Enable</td> <td>Enable</td> <td>Enable</td> <td>Disable</td> <td>Disable</td> </tr> <tr> <td>INT7</td> <td>Enable</td> <td>Enable</td> <td>Enable</td> <td>Disable</td> <td>Disable</td> </tr> </tbody> </table> 		Rising	Falling	Rising & Falling	H Level	L Level	INT4	Enable	Enable	Enable	Disable	Disable	INT5	Enable	Enable	Enable	Disable	Disable	INT6	Enable	Enable	Enable	Disable	Disable	INT7	Enable	Enable	Enable	Disable	Disable	Yes
	Rising	Falling	Rising & Falling	H Level	L Level																												
INT4	Enable	Enable	Enable	Disable	Disable																												
INT5	Enable	Enable	Enable	Disable	Disable																												
INT6	Enable	Enable	Enable	Disable	Disable																												
INT7	Enable	Enable	Enable	Disable	Disable																												
Port 3 P30 to P34	I/O	<ul style="list-style-type: none"> 5-bit I/O port I/O can be specified in 1-bit units Pull-up resistors can be turned on and off in 1-bit units. Pin functions <ul style="list-style-type: none"> P30: UART1 transmit P31: UART1 receive P33: Connected to audio interface PLL filter circuit (see Fig. 6). P34: Connected to USB interface PLL filter circuit (see Fig. 5). 	Yes																														

Continued on next page.

LC87F1K64A

Continued from preceding page.

Pin Name	I/O	Description	Option																														
Port 7	I/O	<ul style="list-style-type: none"> • 4-bit I/O port • I/O can be specified in 1-bit units • Pull-up resistors can be turned on and off in 1-bit units. • Pin functions <ul style="list-style-type: none"> P70: INT0 input / HOLD release input / timer 0L capture input / watchdog timer output P71: INT1 input / HOLD release input / timer 0H capture input P72: INT2 input / HOLD release input / timer 0 event input / timer 0L capture input / high-speed clock counter input P73: INT3 input (input with noise filter) / timer 0 event input / timer 0H capture input / infrared remote control receiver input AD converter input port: AN8 (P70), AN9 (P71) Interrupt acknowledge types <table border="1" style="margin-left: 20px; width: 100%; border-collapse: collapse;"> <thead> <tr> <th></th> <th>Rising</th> <th>Falling</th> <th>Rising & Falling</th> <th>H Level</th> <th>L Level</th> </tr> </thead> <tbody> <tr> <td>INT0</td> <td>Enable</td> <td>Enable</td> <td>Disable</td> <td>Enable</td> <td>Enable</td> </tr> <tr> <td>INT1</td> <td>Enable</td> <td>Enable</td> <td>Disable</td> <td>Enable</td> <td>Enable</td> </tr> <tr> <td>INT2</td> <td>Enable</td> <td>Enable</td> <td>Enable</td> <td>Disable</td> <td>Disable</td> </tr> <tr> <td>INT3</td> <td>Enable</td> <td>Enable</td> <td>Enable</td> <td>Disable</td> <td>Disable</td> </tr> </tbody> </table> 		Rising	Falling	Rising & Falling	H Level	L Level	INT0	Enable	Enable	Disable	Enable	Enable	INT1	Enable	Enable	Disable	Enable	Enable	INT2	Enable	Enable	Enable	Disable	Disable	INT3	Enable	Enable	Enable	Disable	Disable	No
			Rising	Falling	Rising & Falling	H Level	L Level																										
INT0	Enable	Enable	Disable	Enable	Enable																												
INT1	Enable	Enable	Disable	Enable	Enable																												
INT2	Enable	Enable	Enable	Disable	Disable																												
INT3	Enable	Enable	Enable	Disable	Disable																												
P70 to P73																																	
PWM0 PWM1	I/O	PWM0 and PWM1 output port General-purpose input port <ul style="list-style-type: none"> • Pin functions <ul style="list-style-type: none"> PWM0: Audio interface master clock output PWM1: Audio interface master clock input 	No																														
UHAD- UHAD+	I/O	USB-A port data I/O pin / general-purpose I/O port	No																														
UHBD- UHBD+	I/O	USB-B port data I/O pin / general-purpose I/O port	No																														
$\overline{\text{RES}}$	I/O	External reset input / internal reset output	No																														
XT1	I	<ul style="list-style-type: none"> • 32.768kHz crystal resonator input • Pin functions <ul style="list-style-type: none"> General-purpose input port AD converter input port: AN10 	No																														
XT2	I/O	<ul style="list-style-type: none"> • 32.768kHz crystal resonator output • Pin functions <ul style="list-style-type: none"> General-purpose I/O port AD converter input port: AN11 	No																														
CF1	I	Ceramic/crystal resonator input	No																														
CF2	O	Ceramic/crystal resonator output	No																														

On-chip Debugger Pin Treatment

For the treatment of the on-chip debugger pins, refer to the separately available documents entitled "RD87 On-chip Debugger Installation Manual."

Recommended Unused Pin Treatment

Pin Name	Recommended Unused Pin Treatment	
	Board	Software
P00 to P03, P05 to P07	Open	Set output low.
P04	Pull-down with a 100kΩ resistor.	-
P10 to P17	Open	Set output low.
P20 to P25	Open	Set output low.
P30 to P34	Open	Set output low.
P70 to P73	Open	Set output low.
PWM0, PWM1	Open	Set output low.
UHAD+, UHAD-	Open	Set output low.
UHBD+, UHBD-	Open	Set output low.
XT1	Pull-down with a resistor of 100kΩ or lower.	-
XT2	Open	Set output low.

Note: Since P34 is multiplexed with UFILT, it must be configured for input when the USB function is to be used.

Since P33 is multiplexed with AFILT, it must be configured for input when the audio interface PLL circuit is to be used.

Port Output Types

The table below lists the type of port output and the presence/absence of a pull-up resistor.

Data can be read into any input port even if it is in output mode.

Port Name	Option Selected in Units of	Option Type	Output Type	Pull-up Resistor
P00 to P07	1 bit	1	CMOS	Programmable
P10 to P17 P20 to P25 P30 to P34		2	N-channel open drain	Programmable
P70	-	No	N-channel open drain	Programmable
P71 to P73	-	No	CMOS	Programmable
PWM0, PWM1	-	No	CMOS	No
UHAD+, UHAD- UHBD+, UHBD-	-	No	CMOS	No
XT1	-	No	Input only	No
XT2	-	No	32.768kHz crystal resonator output (N-channel open drain when in general-purpose output mode)	No

LC87F1K64A

User Option Table

Option Name	Option to be Applied on	Flash-ROM Version	Option Selected in Units of	Option Selection
Port output type	P00 to P07	○	1 bit	CMOS
				N-channel open drain
	P10 to P17	○	1 bit	CMOS
				N-channel open drain
	P20 to P25	○	1 bit	CMOS
				N-channel open drain
	P30 to P34	○	1 bit	CMOS
				N-channel open drain
Program start address	-	○	-	0000h
				0FE0h
USB regulator	USB regulator	○	-	Use
				Non-use
	USB regulator (HOLD mode)	○	-	Use
				Non-use
	USB regulator (HALT mode)	○	-	Use
				Non-use
Main clock 8MHz selection	-	○	-	Enable
				Disable
Low-voltage detection reset function	Detection function	○	-	Enable: Use
				Disable: Non-use
	Detection level	○	-	7 levels
Power-on reset function	Power-on reset level	○	-	8 levels

LC87F1K64A

USB Reference Power Option

When a voltage 4.5 to 5.5V is supplied to V_{DD1} and the internal USB reference voltage circuit is activated, the reference voltage for USB port output is generated. The active/inactive state of the reference voltage circuit can be switched by selecting an option. The procedure for making the option selection is described below.

Option settings		(1)	(2)	(3)	(4)
	USB regulator	Use	Use	Use	Non-use
	USB regulator at HOLD mode	Use	Non-use	Non-use	Non-use
	USB regulator at HALT mode	Use	Non-use	Use	Non-use
Reference voltage circuit state	Normal mode	Active	Active	Active	Inactive
	HOLD mode	Active	Inactive	Inactive	Inactive
	HALT mode	Active	Inactive	Active	Inactive

- When the USB reference voltage circuit is made inactive, the level of the reference voltage for the USB port output is equal to V_{DD1}.
- Selection (2) or (3) can be used to set the reference voltage circuit inactive in HOLD or HALT mode.
- When the reference voltage circuit is activated, the current drain increases by approximately 100μA compared with when the reference voltage circuit is inactive.

Example 1: V_{DD1}=V_{DD2}=3.3V

- Inactivating the reference voltage circuit (selection (4)).
- Connecting V_{DD3} to V_{DD1} and V_{DD2}.

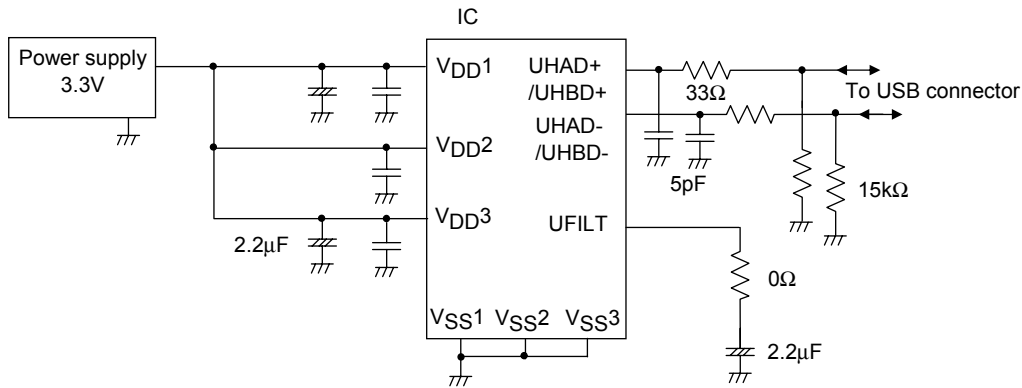

Example 2: V_{DD1}=V_{DD2}=5.0V

- Activating the reference voltage circuit (selection (1)).
- Isolating V_{DD3} from V_{DD1} and V_{DD2}, and connecting capacitor between V_{DD3} and V_{SS}.

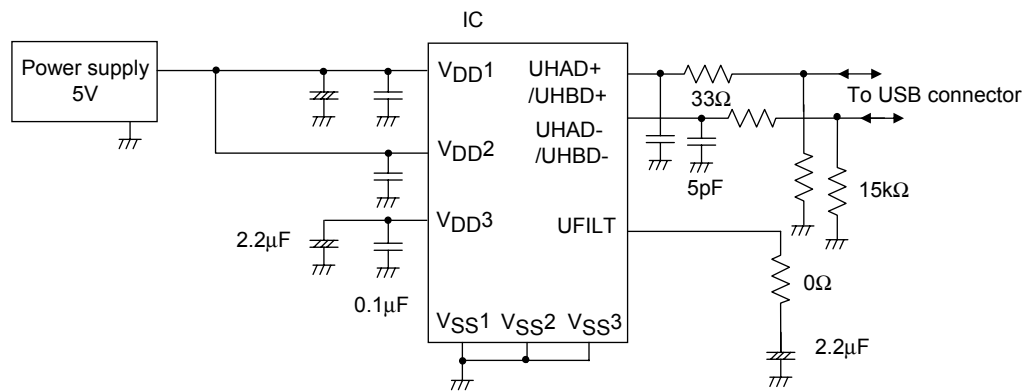

(Note: Do not apply the voltage of more than 3.6V to UHAD+, UHAD-, UHBD+ and UHBD- when the reference voltage circuit is active.)

LC87F1K64A

Absolute Maximum Ratings at Ta = 25°C, VSS1 = VSS2 = VSS3 = 0V

Parameter	Symbol	Pin/Remarks	Conditions	Specification				unit
				VDD[V]	min	typ	max	
Maximum supply voltage	VDD max	VDD1, VDD2, VDD3	VDD1=VDD2=VDD3		-0.3		+6.5	V
Input voltage	VI(1)	XT1, CF1, RES			-0.3		VDD+0.3	
Input/output voltage	VI(1)	Ports 0, 1, 2, 3, 7 PWM0, PWM1 XT2			-0.3		VDD+0.3	
High level output current	Peak output current	IOPH(1)	Ports 0, 1, 2	• When CMOS output type is selected • Per 1 applicable pin			-10	mA
		IOPH(2)	PWM0, PWM1	• Per 1 applicable pin			-20	
		IOPH(3)	Port 3 P71 to P73	• When CMOS output type is selected • Per 1 applicable pin			-5	
	Average output current (Note 1-1)	IOMH(1)	Ports 0, 1, 2	• When CMOS output type is selected • Per 1 applicable pin			-7.5	
		IOMH(2)	PWM0, PWM1	Per 1 applicable pin			-15	
		IOMH(3)	Port 3 P71 to P73	• When CMOS output type is selected • Per 1 applicable pin			-3	
	Total output current	ΣIOAH(1)	Ports 0, 2	Total current of all applicable pins			-25	
		ΣIOAH(2)	Port 1 PWM0, PWM1	Total current of all applicable pins			-25	
		ΣIOAH(3)	Ports 0, 1, 2 PWM0, PWM1	Total current of all applicable pins			-45	
		ΣIOAH(4)	Port 3 P71 to P73	Total current of all applicable pins			-10	
ΣIOAH(5)		UHAD+, UHAD- UHBD+, UHBD-	Total current of all applicable pins			-50		
Low level output current	Peak output current	IOPL(1)	P02 to P07 Ports 1, 2 PWM0, PWM1	Per 1 applicable pin			20	
		IOPL(2)	P00, P01	Per 1 applicable pin			30	
		IOPL(3)	Ports 3, 7 XT2	Per 1 applicable pin			10	
	Average output current (Note 1-1)	IOML(1)	P02 to P07 Ports 1, 2 PWM0, PWM1	Per 1 applicable pin			15	
		IOML(2)	P00, P01	Per 1 applicable pin			20	
		IOML(3)	Ports 3, 7 XT2	Per 1 applicable pin			7.5	
	Total output current	ΣIOAL(1)	Ports 0, 2	Total current of all applicable pins			45	
		ΣIOAL(2)	Port 1 PWM0, PWM1	Total current of all applicable pins			45	
		ΣIOAL(3)	Ports 0, 1, 2 PWM0, PWM1	Total current of all applicable pins			80	
		ΣIOAL(4)	Ports 3, 7 XT2	Total current of all applicable pins			15	
ΣIOAL(5)		UHAD+, UHAD- UHBD+, UHBD-	Total current of all applicable pins			50		
Allowable power dissipation	Pd max	SQFP48(7×7)	Ta=-40 to +85°C				140	mW
Operating ambient Temperature	Topr				-40		+85	°C
Storage ambient temperature	Tstg				-55		+125	

Note 1-1: The average output current is an average of current values measured over 100ms intervals.

Stresses exceeding Maximum Ratings may damage the device. Maximum Ratings are stress ratings only. Functional operation above the Recommended Operating Conditions is not implied. Extended exposure to stresses above the Recommended Operating Conditions may affect device reliability.

LC87F1K64A

Allowable Operating Conditions at $T_a = -40^{\circ}\text{C}$ to $+85^{\circ}\text{C}$, $V_{SS1} = V_{SS2} = V_{SS3} = 0\text{V}$

Parameter	Symbol	Pin/Remarks	Conditions	Specification				unit	
				$V_{DD}[\text{V}]$	min	typ	max		
Operating supply voltage (Note 2-1)	$V_{DD}(1)$	$V_{DD1}=V_{DD2}=V_{DD3}$	$0.245\mu\text{s} \leq t_{CYC} \leq 200\mu\text{s}$		3.0		5.5	V	
			$0.245\mu\text{s} \leq t_{CYC} \leq 0.383\mu\text{s}$ USB circuit active.		3.0		5.5		
			$0.490\mu\text{s} \leq t_{CYC} \leq 200\mu\text{s}$ Except for onboard programming mode		2.7		5.5		
Memory retention supply voltage	VHD	$V_{DD1}=V_{DD2}=V_{DD3}$	RAM and register contents are retained in HOLD mode		2.0		5.5		
High level input voltage	$V_{IH}(1)$	Ports 0, 1, 2, 3, 7 PWM0, PWM1		2.7 to 5.5	$0.3V_{DD} + 0.7$		V_{DD}	V	
	$V_{IH}(2)$	XT1, XT2, CF1, $\overline{\text{RES}}$		2.7 to 5.5	$0.75V_{DD}$		V_{DD}		
Low level input voltage	$V_{IL}(1)$	Ports 1, 2, 3, 7		4.0 to 5.5	V_{SS}		$0.1V_{DD} + 0.4$	V	
	$V_{IL}(2)$			2.7 to 4.0	V_{SS}		$0.2V_{DD}$		
	$V_{IL}(3)$	Port 0 PWM0, PWM1		4.0 to 5.5	V_{SS}		$0.15V_{DD} + 0.4$		
	$V_{IL}(4)$			2.7 to 4.0	V_{SS}		$0.2V_{DD}$		
	$V_{IL}(5)$	XT1, XT2, CF1, $\overline{\text{RES}}$		2.7 to 5.5	V_{SS}		$0.25V_{DD}$		
Instruction cycle time (Note 2-2)	tCYC			3.0 to 5.5	0.245		200	μs	
				USB circuit active.	3.0 to 5.5	0.245			0.383
				Except for onboard programming mode	2.7 to 5.5	0.490			200
External system clock frequency	FEXCF(1)	CF1	<ul style="list-style-type: none"> • CF2 pin open • System clock frequency division ratio =1/1 • External system clock duty =50±5% 	3.0 to 5.5	0.1		12	MHz	
				<ul style="list-style-type: none"> • CF2 pin open • System clock frequency division ratio =1/1 • External system clock duty =50±5% 	2.7 to 5.5	0.1			6
Oscillation frequency range (Note 2-3)	FmCF	CF1, CF2	12MHz ceramic oscillation mode See Fig. 1.	3.0 to 5.5		12		MHz	
	FmRC		Internal medium-speed RC oscillation	2.7 to 5.5	0.5	1.0	2.0		
	FmSRC		Internal low-speed RC oscillation	2.7 to 5.5	15	30	60	kHz	
	FsX'tal	XT1, XT2	32.768kHz crystal oscillation mode See Fig. 2.	2.7 to 5.5		32.768			

Note 2-1: V_{DD} must be held greater than or equal to 3.0V in the flash ROM onboard programming mode.

Note 2-2: Relationship between tCYC and oscillation frequency is $3/F_{mCF}$ at a division ratio of 1/1 and $6/F_{mCF}$ at a division ratio of 1/2.

Note 2-3: See Tables 1 and 2 for the oscillation constants.

LC87F1K64A

Electrical Characteristics at Ta = -40°C to +85°C, VSS1 = VSS2 = VSS3 = 0V

Parameter	Symbol	Pin/Remarks	Conditions	Specification				unit
				VDD[V]	min	typ	max	
High level input current	I _{IH} (1)	Ports 0, 1, 2, 3, 7 $\overline{\text{RES}}$ PWM0, PWM1	Output disabled Pull-up resistor off V _{IN} =V _{DD} (Including output Tr's off leakage current)	2.7 to 5.5			1	μA
	I _{IH} (2)	XT1, XT2	Input port configuration V _{IN} =V _{DD}	2.7 to 5.5			1	
	I _{IH} (3)	CF1	V _{IN} =V _{DD}	2.7 to 5.5			15	
Low level input current	I _{IL} (1)	Ports 0, 1, 2, 3, 7 $\overline{\text{RES}}$ PWM0, PWM1	Output disabled Pull-up resistor off V _{IN} =V _{SS} (Including output Tr's off leakage current)	2.7 to 5.5	-1			μA
	I _{IL} (2)	XT1, XT2	Input port configuration V _{IN} =V _{SS}	2.7 to 5.5	-1			
	I _{IL} (3)	CF1	V _{IN} =V _{SS}	2.7 to 5.5	-15			
High level output voltage	V _{OH} (1)	Ports 0, 1, 2, 3 P71 to P73	I _{OH} =-1mA	4.5 to 5.5	V _{DD} -1			V
	V _{OH} (2)		I _{OH} =-0.4mA	3.0 to 5.5	V _{DD} -0.4			
	V _{OH} (3)		I _{OH} =-0.2mA	2.7 to 5.5	V _{DD} -0.4			
	V _{OH} (4)	PWM0, PWM1	I _{OH} =-10mA	4.5 to 5.5	V _{DD} -1.5			
	V _{OH} (5)	P05 to P07 (Note 3-1)	I _{OH} =-1.6mA	3.0 to 5.5	V _{DD} -0.4			
	V _{OH} (6)		I _{OH} =-1mA	2.7 to 5.5	V _{DD} -0.4			
Low level output voltage	V _{OL} (1)	P00, P01	I _{OL} =30mA	4.5 to 5.5			1.5	V
	V _{OL} (2)		I _{OL} =5mA	3.0 to 5.5			0.4	
	V _{OL} (3)		I _{OL} =2.5mA	2.7 to 5.5			0.4	
	V _{OL} (4)	Ports 0, 1, 2 PWM0, PWM1	I _{OL} =10mA	4.5 to 5.5			1.5	
	V _{OL} (5)		I _{OL} =1.6mA	3.0 to 5.5			0.4	
	V _{OL} (6)	XT2	I _{OL} =1mA	2.7 to 5.5			0.4	
	V _{OL} (7)	Ports 3, 7	I _{OL} =1.6mA	3.0 to 5.5			0.4	
	V _{OL} (8)		I _{OL} =1mA	2.7 to 5.5			0.4	
Pull-up resistance	R _{pu} (1)	Ports 0, 1, 2, 3, 7	V _{OH} =0.9V _{DD}	4.5 to 5.5	15	35	80	kΩ
	R _{pu} (2)			2.7 to 4.5	18	50	150	
Hysteresis voltage	V _{HYS}	$\overline{\text{RES}}$ Ports 1, 2, 3, 7		2.7 to 5.5		0.1V _{DD}		V
Pin capacitance	CP	All pins	For pins other than those under test: V _{IN} =V _{SS} f=1MHz Ta=25°C	2.7 to 5.5		10		pF

Note 3-1: When the CKO system clock output function (P05) or the audio interface output function (P05 to P07) is used.

LC87F1K64A

Serial I/O Characteristics at Ta = -40°C to +85°C, VSS1 = VSS2 = VSS3 = 0V

1. SIO0 Serial I/O Characteristics (Note 4-1-1)

Parameter	Symbol	Pin/ Remarks	Conditions	VDD[V]	Specification							
					min	typ	max	unit				
Serial clock	Input clock	Frequency	tSCK(1)	SCK0(P12)	2.7 to 5.5				tCYC			
		Low level pulse width	tSCKL(1)							See Fig. 9.	2	
		High level pulse width	tSCKH(1)								1	
			tSCKHA(1a)	<ul style="list-style-type: none"> • Continuous data transmission/reception mode • USB, AIF, SIO4 not used at the same time. • See Fig. 9. • (Note 4-1-2) 							1	
			tSCKHA(1b)							<ul style="list-style-type: none"> • Continuous data transmission/reception mode • USB used at the same time • AIF, SIO4 not used at the same time. • See Fig. 9. • (Note 4-1-2) 	4	
			tSCKHA(1c)								7	
						9						
	Serial clock	Output clock	Frequency	tSCK(2)	SCK0(P12)	2.7 to 5.5				tSCK		
			Low level pulse width	tSCKL(2)							<ul style="list-style-type: none"> • When CMOS output type is selected. • See Fig. 9. 	4/3
High level pulse width			tSCKH(2)	1/2								
			tSCKHA(2a)	<ul style="list-style-type: none"> • Continuous data transmission/reception mode • USB, AIF, SIO4 not used at the same time. • When CMOS output type is selected. • See Fig. 9. 	1/2							
			tSCKHA(2b)		<ul style="list-style-type: none"> • Continuous data transmission/reception mode • USB used at the same time • AIF, SIO4 not used at the same time. • When CMOS output type is selected. • See Fig. 9. 						tSCKH(2) +2tCYC	tSCKH(2) + (10/3)tCYC
			tSCKHA(2c)								<ul style="list-style-type: none"> • Continuous data transmission/reception mode • USB, AIF, SIO4 used at the same time • When CMOS output type is selected. • See Fig. 9. 	tSCKH(2) +2tCYC
					tSCKH(2) +2tCYC	tSCKH(2) + (25/3)tCYC						

Note 4-1-1: These specifications are theoretical values. Margins must be allowed according to the actual operating conditions.

Note 4-1-2: In an application where the serial clock input is to be used in continuous data transmission/reception mode, the time from SI0RUN being set when serial clock is high to the falling edge of the first serial clock must be longer than tSCKHA.

Continued on next page.

LC87F1K64A

Continued from preceding page.

Parameter		Symbol	Pin/ Remarks	Conditions	V _{DD} [V]	Specification			
						min	typ	max	unit
Serial input	Data setup time	tsDI(1)	SB0(P11), SI0(P11)	<ul style="list-style-type: none"> • Must be specified with respect to rising edge of SIOCLK • See Fig. 9. 	2.7 to 5.5	0.03			
	Data hold time	thDI(1)				0.03			
Serial output	Output delay time	tdDO(1)	SO0(P10), SB0(P11)	<ul style="list-style-type: none"> • Continuous data transmission/reception mode • (Note 4-1-3) 	2.7 to 5.5			(1/3)tCYC +0.05	μs
		tdDO(2)				<ul style="list-style-type: none"> • Synchronous 8-bit mode • (Note 4-1-3) 			
		tdDO(3)		(Note 4-1-3)				(1/3)tCYC +0.05	

Note 4-1-3: Must be specified with respect to falling edge of SIOCLK. Must be defined as the time up to the beginning of output state change in open drain output mode. See Fig. 9.

2. SIO1 Serial I/O Characteristics (Note 4-2-1)

Parameter		Symbol	Pins/ Remarks	Conditions	V _{DD} [V]	Specification				
						min	typ	max	unit	
Serial clock	Input clock	Frequency	SCK1(P15)	• See Fig. 9.	2.7 to 5.5	2			tCYC	
		Low level pulse width				tSCKL(3)	1			
		High level pulse width				tSCKH(3)	1			
	Output clock	Frequency	SCK1(P15)	<ul style="list-style-type: none"> • When CMOS output type is selected. • See Fig. 9. 	2.7 to 5.5	2			tSCK	
		Low level pulse width				tSCKL(4)	1/2			
		High level pulse width				tSCKH(4)	1/2			
Serial input	Data setup time	tsDI(2)	SB1(P14), SI1(P14)	<ul style="list-style-type: none"> • Must be specified with respect to rising edge of SIOCLK. • See Fig. 9. 	2.7 to 5.5	0.03				
	Data hold time	thDI(2)				0.03				
Serial output	Output delay time	tdD0(4)	SO1(P13), SB1(P14)	<ul style="list-style-type: none"> • Must be specified with respect to falling edge of SIOCLK. • Must be specified as the time up to the beginning of output state change in open drain output mode. • See Fig. 9. 	2.7 to 5.5			(1/3)tCYC +0.05	μs	

Note 4-2-1: These specifications are theoretical values. Margins must be allowed according to the actual operating conditions.

LC87F1K64A

3. SIO4 Serial I/O Characteristics (Note 4-3-1)

Parameter	Symbol	Pin/ Remarks	Conditions	V _{DD} [V]	Specification					
					min	typ	max	unit		
Serial clock	Input clock	Frequency	tSCK(5)	SCK4(P24)	2.7 to 5.5	See Fig. 9.	2			tCYC
		Low level pulse width	tSCKL(5)				1			
		High level pulse width	tSCKH(5)				1			
			tSCKHA(5a)	4						
			tSCKHA(5b)							
		tSCKHA(5c)	10							
	Output clock	Frequency	tSCK(6)	SCK4(P24)	2.7 to 5.5	When CMOS output type is selected. • See Fig. 9.	4/3			tSCK
		Low level pulse width	tSCKL(6)				1/2			
		High level pulse width	tSCKH(6)				1/2			
			tSCKHA(6a)	tSCKH(6) + (5/3)tCYC			tSCKH(6) + (10/3)tCYC	tCYC		
			tSCKHA(6b)	tSCKH(6) + (5/3)tCYC			tSCKH(6) + (19/3)tCYC			
		tSCKHA(6c)	tSCKH(6) + (5/3)tCYC	tSCKH(6) + (28/3)tCYC						
Serial input	Data setup time	tsDI(3)	SO4(P22), SI4(P23)	2.7 to 5.5	Must be specified with respect to rising edge of SIOCLK. • See Fig. 9.	0.03			μs	
	Data hold time	thDI(3)				0.03				
Serial output	Output delay time	tdDO(5)	SO4(P22), SI4(P23)	2.7 to 5.5	Must be specified with respect to falling edge of SIOCLK. • Must be specified as the time up to the beginning of output state change in open drain output mode • See Fig. 9.			(1/3)tCYC +0.05		

Note 4-3-1: These specifications are theoretical values. Margins must be allowed according to the actual operating conditions.

Note 4-3-2: In an application where the serial clock input is to be used, the time from SI4RUN being set when serial clock is high to the falling edge of the first serial clock must be longer than tSCKHA when continuous data transmission/reception is started.

LC87F1K64A

4-1. SMIIC0 Simple SIO Mode I/O Characteristics (Note 4-4-1)

Parameter		Symbol	Pin/Remarks	Conditions	V _{DD} [V]	Specification				
						min	typ	max	unit	
Serial clock	Input clock	Frequency	tSCK(7)	SM0CK0(P17), SM0CK1(P13)	See Fig. 9.	2.7 to 5.5	4/3			tCYC
		Low level pulse width	tSCKL(7)				2/3			
		High level pulse width	tSCKH(7)				2/3			
	Output clock	Frequency	tSCK(8)	SM0CK0(P17), SM0CK1(P13)	<ul style="list-style-type: none"> When CMOS output type is selected. See Fig. 9. 	2.7 to 5.5	4/3			tSCK
		Low level pulse width	tSCKL(8)				1/2			
		High level pulse width	tSCKH(8)				1/2			
Serial input	Data setup time	tsDI(4)	SM0DA0(P16), SM0DA1(P14)	<ul style="list-style-type: none"> Must be specified with respect to rising edge of SIOCLK. See Fig. 9. 	2.7 to 5.5	0.03			μs	
	Data hold time	thDI(4)				0.03				
Serial output	Output delay time	tdDO(6)	SM0DO(P15), SM0DA0(P16), SM0DA1(P14)	<ul style="list-style-type: none"> Must be specified with respect to falling edge of SIOCLK. Must be specified as the time to the beginning of output state change. See Fig. 9. 	2.7 to 5.5			(1/3)tCYC +0.05	μs	

Note 4-4-1: These specifications are theoretical values. Margins must be allowed according to the actual operating conditions.

LC87F1K64A

4-2. SMIIC0 I²C Mode I/O Characteristics (Note 4-5-1)

Parameter		Symbol	Pin/Remarks	Conditions	V _{DD} [V]	Specification				
						min	typ	max	unit	
Serial clock	Input clock	Frequency	tSCL	SM0CK0(P17), SM0CK1(P13)	See Fig. 11.	2.7 to 5.5	5			Tfilit
		Low level pulse width	tSCLL				2.5			
		High level pulse width	tSCLH				2			
	Output clock	Frequency	tSCLx	SM0CK0(P17), SM0CK1(P13)	Must be specified as the time up to the beginning of output state change.	2.7 to 5.5	10			tSCL
		Low level pulse width	tSCLLx				1/2			
		High level pulse width	tSCLHx				1/2			
SM0CK, SM0DA pin input spike suppression time		tsp	SM0CK0(P17), SM0CK1(P13), SM0DA0(P16), SM0DA1(P14)	See Fig. 11.	2.7 to 5.5			1	Tfilit	
Bus relinquish time between start and stop		input	tBUF	SM0CK0(P17), SM0CK1(P13), SM0DA0(P16), SM0DA1(P14)	See Fig. 11.	2.7 to 5.5	2.5			Tfilit
		<ul style="list-style-type: none"> • High-speed clock mode • Must be specified as the time up to the beginning of output state change. 	1.6							
Start, restart condition hold time		input	tHD; STA	SM0CK0(P17), SM0CK1(P13), SM0DA0(P16), SM0DA1(P14)	<ul style="list-style-type: none"> • When SMIIC register control bit SHDS=0 • See Fig. 11. 	2.7 to 5.5	2.0			Tfilit
		Output	tHD; STAx	<ul style="list-style-type: none"> • Standard clock mode • Must be specified as the time up to the beginning of output state change. 	4.1				μs	
				<ul style="list-style-type: none"> • High-speed clock mode • Must be specified as the time up to the beginning of output state change. 						1.0
Restart condition setup time		input	tSU; STA	SM0CK0(P17), SM0CK1(P13), SM0DA0(P16), SM0DA1(P14)	See Fig. 11.	2.7 to 5.5	1.0			Tfilit
		<ul style="list-style-type: none"> • High-speed clock mode • Must be specified as the time up to the beginning of output state change. 	1.6							

Continued on next page.

LC87F1K64A

Continued from preceding page.

Parameter	Symbol	Pin/Remarks	Conditions	V _{DD} [V]	Specification						
					min	typ	max	unit			
Stop condition setup time	Input	tSU; STO	SM0CK0(P17), SM0CK1(P13), SM0DA0(P16), SM0DA1(P14)	See Fig. 11.	2.7 to 5.5	1.0			T _{filt}		
	Output	tSU; STOx				<ul style="list-style-type: none"> • Standard clock mode • Must be specified as the time up to the beginning of output state change. 	4.9				μs
						<ul style="list-style-type: none"> • High-speed clock mode • Must be specified as the time up to the beginning of output state change. 	1.1				
Data hold time	Input	tHD; DAT	SM0CK0(P17), SM0CK1(P13), SM0DA0(P16), SM0DA1(P14)	See Fig. 11.	2.7 to 5.5	0			T _{filt}		
	Output	tHD; DATx				Must be specified as the time up to the beginning of output state change.	1			1.5	
Data setup time	Input	tSU; DAT	SM0CK0(P17), SM0CK1(P13), SM0DA0(P16), SM0DA1(P14)	See Fig. 11.	2.7 to 5.5	1			T _{filt}		
	Output	tSU; DATx				Must be specified as the time up to the beginning of output state change.	1t _{SCL} -1.5T _{filt}				

Note 4-5-1: These specifications are theoretical values. Margins must be allowed according to the actual operating conditions.

Note 4-5-2: The value of T_{filt} is determined by bits 7 and 6 (BRP1 and BRP0) of the SMIC0BRG register and the system clock frequency.

BRP1	BRP0	T _{filt}
0	0	(1/3) t _{CYC} ×1
0	1	(1/3) t _{CYC} ×2
1	0	(1/3) t _{CYC} ×3
1	1	(1/3) t _{CYC} ×4

Set the value of the BRP1 and BRP0 bits so that the value of T_{filt} falls within the following value range:
250ns ≥ T_{filt} > 140ns

Note 4-5-3: For standard clock mode operation, set up the SMIC0BRG register so that the following conditions are satisfied:

- 250ns ≥ T_{filt} > 140ns
- BRDQ (bit5) = 1
- SCL frequency value ≤ 100kHz

For high-speed clock mode operation, set up the SMIC0BRG register so that the following conditions are satisfied:

- 250ns ≥ T_{filt} > 140ns
- BRDQ (bit5) = 1
- SCL frequency value ≤ 400kHz

LC87F1K64A

Pulse Input Conditions at Ta = -40°C to +85°C, VSS1 = VSS2 = VSS3 = 0V

Parameter	Symbol	Pin/Remarks	Conditions	Specification				
				VDD[V]	min	typ	max	unit
High/low level pulse width	tPIH(1) tPIL(1)	INT0(P70), INT1(P71), INT2(P72), INT4(P20 to P23), INT5(P24 to P25), INT6(P20), INT7(P24)	<ul style="list-style-type: none"> Interrupt source flag can be set. Event inputs for timer 0/1 are enabled. 	2.7 to 5.5	1			tCYC
	tPIH(2) tPIL(2)	INT3(P73) when noisefilter time constant is 1/1.	<ul style="list-style-type: none"> Interrupt source flag can be set. Event inputs for timer 0 are enabled. 	2.7 to 5.5	2			
	tPIH(3) tPIL(3)	INT3(P73) when noisefilter time constant is 1/32.	<ul style="list-style-type: none"> Interrupt source flag can be set. Event inputs for timer 0 are enabled. 	2.7 to 5.5	64			
	tPIH(4) tPIL(4)	INT3(P73) when noisefilter time constant is 1/128.	<ul style="list-style-type: none"> Interrupt source flag can be set. Event inputs for timer 0 are enabled. 	2.7 to 5.5	256			
	tPIL(5)	RMIN(P73)	Recognized as a signal by infrared remote control receiver circuit	2.7 to 5.5	4			
	tPIL(6)	$\overline{\text{RES}}$		Resetting is enabled.	2.7 to 5.5	200		

Note 5-1: Denotes the reference frequency of the infrared remote control receiver circuit (1tCYC to 128tCYC or source oscillation frequency of the subclock)

LC87F1K64A

AD Converter Characteristics at Ta = -40°C to +85°C, VSS1 = VSS2 = VSS3 = 0V

<12-bit AD Converter Mode>

Parameter	Symbol	Pin/Remarks	Conditions	Specification				
				V _{DD} [V]	min	typ	max	unit
Resolution	N	AN0(P00) to AN7(P07) AN8(P70) AN9(P71) AN10(XT1) AN11(XT2)		3.0 to 5.5		12		bit
Absolute accuracy	ET		(Note 6-1)	3.0 to 5.5			±16	LSB
Conversion time	TCAD		See conversion time calculation formulas. (Note 6-2)	4.0 to 5.5	32		115	μs
				3.0 to 5.5	64		115	
Analog input voltage range	VAIN			3.0 to 5.5	V _{SS}		V _{DD}	V
Analog port input current	I _{AINH}	VAIN=V _{DD}	3.0 to 5.5			1	μA	
	I _{AINL}	VAIN=V _{SS}	3.0 to 5.5	-1				

<8-bit AD Converter Mode>

Parameter	Symbol	Pin/Remarks	Conditions	Specification				
				V _{DD} [V]	min	typ	max	unit
Resolution	N	AN0(P00) to AN7(P07) AN8(P70) AN9(P71) AN10(XT1) AN11(XT2)		3.0 to 5.5		8		bit
Absolute accuracy	ET		(Note 6-1)	3.0 to 5.5			±1.5	LSB
Conversion time	TCAD		See conversion time calculation formulas. (Note 6-2)	4.0 to 5.5	20		90	μs
				3.0 to 5.5	40		90	
Analog input voltage range	VAIN			3.0 to 5.5	V _{SS}		V _{DD}	V
A Analog port input current	I _{AINH}	VAIN=V _{DD}	3.0 to 5.5			1	μA	
	I _{AINL}	VAIN=V _{SS}	3.0 to 5.5	-1				

Conversion time calculation formulas :

12-bits AD Converter Mode : TCAD (Conversion time) = ((52/(AD division ratio))+2) × (1/3) × tCYC

8-bits AD Converter Mode : TCAD (Conversion time) = ((32/(AD division ratio))+2) × (1/3) × tCYC

<Recommended Operating Conditions>

External Oscillator FmCF[MHz]	Supply Voltage Range V _{DD} [V]	System Clock Division (SYSDIV)	Cycle Time tCYC [ns]	AD Frequency Division Ratio (ADDIV)	Conversion Time (TCAD)[μs]	
					12-bit AD	8-bit AD
12	4.0 to 5.5	1/1	250	1/8	34.8	21.5
	3.0 to 5.5	1/1	250	1/16	69.5	42.8

Note 6-1: The quantization error (±1/2LSB) must be excluded from the absolute accuracy. The absolute accuracy must be measured in the microcontroller's state in which no I/O operations occur at the pins adjacent to the analog input channel.

Note 6-2: The conversion time refers to the period from the time an instruction for starting a conversion process until the time the conversion result register is loaded with a complete digital conversion value corresponding to the analog input value.

The conversion time is doubled in the following cases:

- The AD conversion is carried out in the 12-bit AD conversion mode for the first time after a system reset.
- The AD conversion is carried out for the first time after the AD conversion mode is switched from 8-bit to 12-bit AD conversion mode.

LC87F1K64A

Power-on Reset (POR) Characteristics at Ta = -40°C to +85°C, VSS1 = VSS2 = VSS3 = 0V

Parameter	Symbol	Conditions	Option selected voltage	Specification			unit
				min	typ	max	
POR release voltage	PORRL	Select from option (Note 7-1)	1.67V	1.55	1.67	1.79	V
			1.97V	1.85	1.97	2.09	
			2.07V	1.95	2.07	2.19	
			2.37V	2.25	2.37	2.49	
			2.57V	2.45	2.57	2.69	
			2.87V	2.75	2.87	2.99	
			3.86V	3.73	3.86	3.99	
			4.35V	4.21	4.35	4.49	
Detection voltage unknown state	POUKS	See Fig. 13 (Note 7-2)			0.7	0.95	
Power supply rise time	PORIS	Power supply rise time from VDD=0V to 1.6V				100	ms

Note 7-1: The POR release level can be selected out of 8 levels only when LDV reset function is disabled.

Note 7-2: POR is in unknown state before transistors start operation.

Low Voltage Detection (LVD) Characteristics at Ta = -40°C to +85°C, VSS1 = VSS2 = VSS3 = 0V

Parameter	Symbol	Conditions	Option selected voltage	Specification			unit
				min	typ	max	
LVD reset voltage (Note 8-2)	LVDET	Select from option. See Fig. 14. (Note 8-1) (Note 8-3)	1.91V	1.81	1.91	2.01	V
			2.01V	1.91	2.01	2.11	
			2.31V	2.21	2.31	2.41	
			2.51V	2.41	2.51	2.61	
			2.81V	2.71	2.81	2.91	
			3.79V	3.69	3.79	3.89	
			4.28V	4.18	4.28	4.38	
LVD hysteresis width	LVHYS		1.91V		55		mV
			2.01V		55		
			2.31V		55		
			2.51V		55		
			2.81V		55		
			3.79V		60		
			4.28V		65		
Detection voltage unknown state	LVUKS	See Fig. 14. (Note 8-4)			0.7	0.95	V
Low voltage detection minimum width (Reply sensitivity)	TLVDW	LVDET-0.5V See Fig. 15.		0.2			ms

Note 8-1: The LVD reset level can be selected out of 7 levels only when the LVD reset function is enabled.

Note 8-2: LVD reset voltage specification values do not include hysteresis voltage.

Note 8-3: LVD reset voltage may exceed its specification values when port output state changes and/or when a large current flows through port.

Note 8-4: LVD is in an unknown state before transistors start operation.

LC87F1K64A

Consumption Current Characteristics at Ta = -40°C to +85°C, VSS1 = VSS2 = VSS3 = 0V

Parameter	Symbol	Pin/ Remarks	Conditions	Specification				
				VDD[V]	min	typ	max	unit
Normal mode consumption current (Note 9-1) (Note 9-2)	IDDOP(1)	VDD1 = VDD2 = VDD3	<ul style="list-style-type: none"> • FmCF=12MHz ceramic oscillation mode • FsX'tal=32.768kHz crystal oscillation mode • System clock set to 12MHz side • Internal PLL oscillation stopped • Internal low-/medium-speed RC oscillation stopped • USB circuit stopped • 1/1 frequency division ratio 	4.5 to 5.5		9.8	18	mA
				3.0 to 3.6		5.7	11	
	IDDOP(2)		<ul style="list-style-type: none"> • FmCF=12MHz ceramic oscillation mode • FsX'tal=32.768kHz crystal oscillation mode • System clock set to 12MHz side • Internal PLL oscillation mode active • Internal low-/medium-speed RC oscillation stopped • USB circuit active • 1/1 frequency division ratio 	4.5 to 5.5		15	28	
				3.0 to 3.6		8.1	15	
	IDDOP(3)		<ul style="list-style-type: none"> • FmCF=12MHz ceramic oscillation mode • FsX'tal=32.768kHz crystal oscillation mode • System clock set to 6MHz side • Internal low-/medium-speed RC oscillation stopped • 1/2 frequency division ratio 	4.5 to 5.5		6.7	12	
				3.0 to 3.6		4.2	7.1	
				2.7 to 3.0		3.5	5.8	
	IDDOP(4)		<ul style="list-style-type: none"> • External oscillation FmCF stopped • FsX'tal=32.768kHz crystal oscillation mode • System clock set to internal medium-speed RC oscillation • Internal low-speed RC oscillation stopped • 1/2 frequency division ratio 	4.5 to 5.5		0.77	2.8	
				3.0 to 3.6		0.46	1.5	
				2.7 to 3.0		0.39	1.3	
	IDDOP(5)		<ul style="list-style-type: none"> • External oscillation FsX'tal /FmCF stopped • System clock set to internal low-speed RC oscillation • Internal medium-speed RC oscillation stopped • 1/1 frequency division ratio 	4.5 to 5.5		28	170	
				3.0 to 3.6		18	100	
2.7 to 3.0				16	87			
IDDOP(6)	<ul style="list-style-type: none"> • External oscillation FmCF stopped • FsX'tal=32.768kHz crystal oscillation mode • System clock set to 32.768kHz side • Internal low-/medium-speed RC oscillation stopped • 1/2 frequency division ratio 	4.5 to 5.5		45	124			
		3.0 to 3.6		18	60			
		2.7 to 3.0		14	48			
HALT mode consumption current (Note 9-1) (Note 9-2)	IDDHALT(1)	<ul style="list-style-type: none"> • HALT mode • FmCF=12MHz ceramic oscillation mode • FsX'tal=32.768kHz crystal oscillation mode • System clock set to 12MHz side • Internal PLL oscillation stopped • Internal low-/medium-speed RC oscillation stopped • USB circuit stopped • 1/1 frequency division ratio 	4.5 to 5.5		4.0	7.0	mA	
			3.0 to 3.6		2.2	3.8		

Note 9-1: The consumption current value do not include current that flows into the output transistors and internal pull-up resistors.

Note 9-2: The consumption current values do not include operational current of LVD (Low Voltage Detection) function if not specified.

Continued on next page.

LC87F1K64A

Continued from preceding page.

Parameter	Symbol	Pin/ Remarks	Conditions	Specification				
				V _{DD} [V]	min	typ	max	unit
HALT mode consumption current (Note 9-1) (Note 9-2)	IDDHALT(2)	V _{DD} 1 =V _{DD} 2 =V _{DD} 3	<ul style="list-style-type: none"> • HALT mode • FmCF=12MHz ceramic oscillation mode • FsX'tal=32.768kHz crystal oscillation mode • System clock set to 12MHz side • Internal PLL oscillation active • Internal low-/medium-speed RC oscillation stopped • USB circuit active • 1/1 frequency division ratio 	4.5 to 5.5		9.2	18	mA
				3.0 to 3.6		4.7	8.6	
	IDDHALT(3)		4.5 to 5.5		2.5	4.5		
			3.0 to 3.6		1.3	2.3		
			2.7 to 3.0		1.1	1.8		
	IDDHALT(4)		4.5 to 5.5		0.41	1.5		
			3.0 to 3.6		0.20	0.72		
			2.7 to 3.0		0.17	0.53		
	IDDHALT(5)		4.5 to 5.5		7.2	95		
			3.0 to 3.6		4.0	51		
			2.7 to 3.0		3.4	43		
	IDDHALT(6)		4.5 to 5.5		30	112		
3.0 to 3.6			8.4	51				
2.7 to 3.0			5.8	40				
HOLD mode consumption current (Note 9-1) (Note 9-2)	IDDHOLD(1)	<ul style="list-style-type: none"> • HOLD mode • CF1=V_{DD} or open (External clock mode) 	4.5 to 5.5		0.28	67	μA	
			3.0 to 3.6		0.22	35		
			2.7 to 3.0		0.21	30		
	IDDHOLD(2)		4.5 to 5.5		2.8	70		
			3.0 to 3.6		2.3	38		
			2.7 to 3.0		2.1	33		
IDDHOLD(3)	4.5 to 5.5		0.98	68				
	3.0 to 3.6		0.62	36				
	2.7 to 3.0		0.51	31				
X'tal HOLD mode consumption current (Note 9-1) (Note 9-2)	IDDHOLD(4)	<ul style="list-style-type: none"> • X'tal HOLD mode • CF1=V_{DD} or open (External clock mode) • FsX'tal=32.768kHz crystal oscillation mode 	4.5 to 5.5		26	106		
			3.0 to 3.6		6.1	49		
			2.7 to 3.0		3.8	38		
	IDDHOLD(5)		4.5 to 5.5		1.0	68		
			3.0 to 3.6		0.64	36		
			2.7 to 3.0		0.53	31		

Note 9-1: The consumption current value do not include current that flows into the output transistors and internal pull-up resistors.

Note 9-2: The consumption current values do not include operational current of LVD (Low Voltage Detection) function if not specified.

LC87F1K64A

USB Characteristics and Timing at $T_a = -40^{\circ}\text{C}$ to $+85^{\circ}\text{C}$, $V_{SS1} = V_{SS2} = V_{SS3} = 0\text{V}$

Parameter	Symbol	Pin/Remarks	Conditions			
			min	typ	max	unit
High level output	$V_{OH(USB)}$	• $15\text{k}\Omega \pm 5\%$ to GND	2.8		3.6	V
Low level output	$V_{OL(USB)}$	• $1.5\text{k}\Omega \pm 5\%$ to 3.6V	0.0		0.3	V
Output signal crossover voltage	V_{CRS}		1.3		2.0	V
Differential input sensitivity	V_{DI}	• $ (UHAD+) - (UHAD-) $ • $ (UHBD+) - (UHBD-) $	0.2			V
Differential input common mode range	V_{CM}		0.8		2.5	V
High level input	$V_{IH(USB)}$		2.0		3.6	V
Low level input	$V_{IL(USB)}$		0.0		0.8	V
Rise time (full-speed)	t_{FR}	$R_S=33\Omega$, $C_L=50\text{pF}$	4		20	ns
Fall time (full-speed)	t_{FF}	$R_S=33\Omega$, $C_L=50\text{pF}$	4		20	ns
Rise time (low-speed)	t_{LR}	$R_S=33\Omega$, $C_L=200$ to 600pF	75		300	ns
Fall time (low-speed)	t_{LF}	$R_S=33\Omega$, $C_L=200$ to 600pF	75		300	ns

F-ROM Programming Characteristics at $T_a = +10^{\circ}\text{C}$ to $+55^{\circ}\text{C}$, $V_{SS1} = V_{SS2} = V_{SS3} = 0\text{V}$

Parameter	Symbol	Pin/Remarks	Conditions	Specification				
				$V_{DD}[\text{V}]$	min	typ	max	unit
Onboard programming current	IDDFW(1)	V_{DD1}	• Excluding power dissipation in the microcontroller block	3.0 to 5.5		5	10	mA
Programming time	$t_{FW(1)}$		• Erase operation	3.0 to 5.5		20	30	ms
	$t_{FW(2)}$		• Write operation			40	60	μs

Main System Clock Oscillation

The characteristics of a sample main system clock oscillator circuit shown in Table 1 are measured using a Our specification oscillation characteristics evaluation board and external components with circuit constant values with which the resonator vendor confirmed normal and stable oscillation.

Table 1 shows the characteristics of a oscillator circuit when USB host function is not used. If USB host function is to be used, it is absolutely recommended to use a resonator that satisfies the precision and stability according to the USB standards ($\pm 500\text{ppm}$)

Table 1 Characteristics of a Sample Main System Clock Oscillator Circuit with a Ceramic Resonator

Nominal Frequency	Vendor Name	Resonator Name	Circuit Constant			Operating Voltage Range [V]	Oscillation Stabilization Time		Remarks
			C1 [pF]	C2 [pF]	Rd1 [Ω]		typ [ms]	max [ms]	
12MHz	MURATA	CSTCE12M0GH5L**-R0	(33)	(33)	470	3.0 to 5.5	0.1	0.5	C1 and C2 integrated SMD type

The oscillation stabilization time is required for the oscillator to get stabilized in the following cases (see Figure 4):

- Until oscillation is stabilized after VDD goes above the operating voltage lower limit
- Until oscillation is stabilized after the instruction for starting the main clock oscillator circuit is executed
- Until oscillation is stabilized after HOLD mode is released.
- Until oscillation is stabilized after X'tal HOLD mode is released with CFSTOP (OCR register, bit 0) set to 0 and oscillation is started.

Subsystem Clock Oscillation

Table 2 shows the characteristics of a sample subsystem clock oscillator circuit that are measured using a Our specification oscillation characteristics evaluation board and external components with circuit constant values with which the resonator vendor confirmed normal and stable oscillation.

Table 2 Characteristics of a Sample Subsystem Clock Oscillator Circuit with a Crystal Resonator

Nominal Frequency	Vendor Name	Resonator Name	Circuit Constant				Operating Voltage Range [V]	Oscillation Stabilization Time		Remarks
			C3 [pF]	C4 [pF]	Rf [Ω]	Rd2 [Ω]		typ [s]	max [s]	
32.768kHz	EPSON TOYOCOM	MC-306	18	18	Open	680k	2.7 to 5.5	1.1	3.0	Applicable CL value=12.5pF SMD type

The oscillation stabilization time is required for the oscillator to get stabilized in the following cases (see Figure 4):

- Until oscillation is stabilized after the instruction for starting the subclock oscillator circuit is executed
- Until oscillation is stabilized after HOLD mode is released with EXTOSC (OCR register, bit 6) set to 1 and oscillation is started.

Note: The components that are involved in oscillation should be placed as close to the IC and to one another as possible because they are vulnerable to the influences of the circuit pattern.

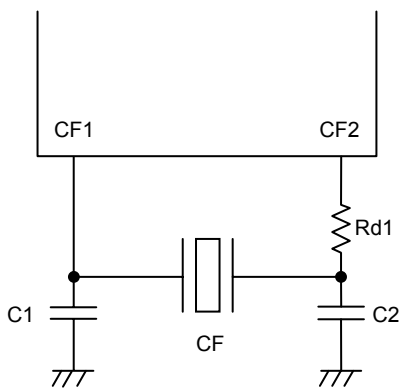

Figure 1 CF Oscillator Circuit

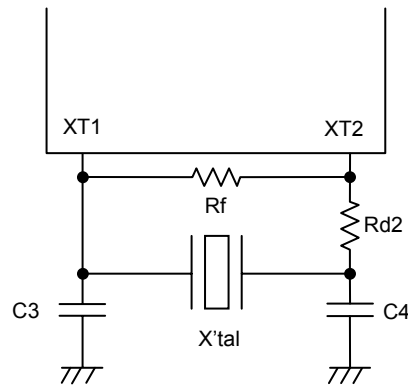

Figure 2 Crystal Oscillator Circuit

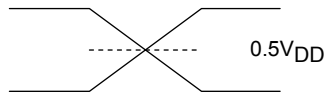
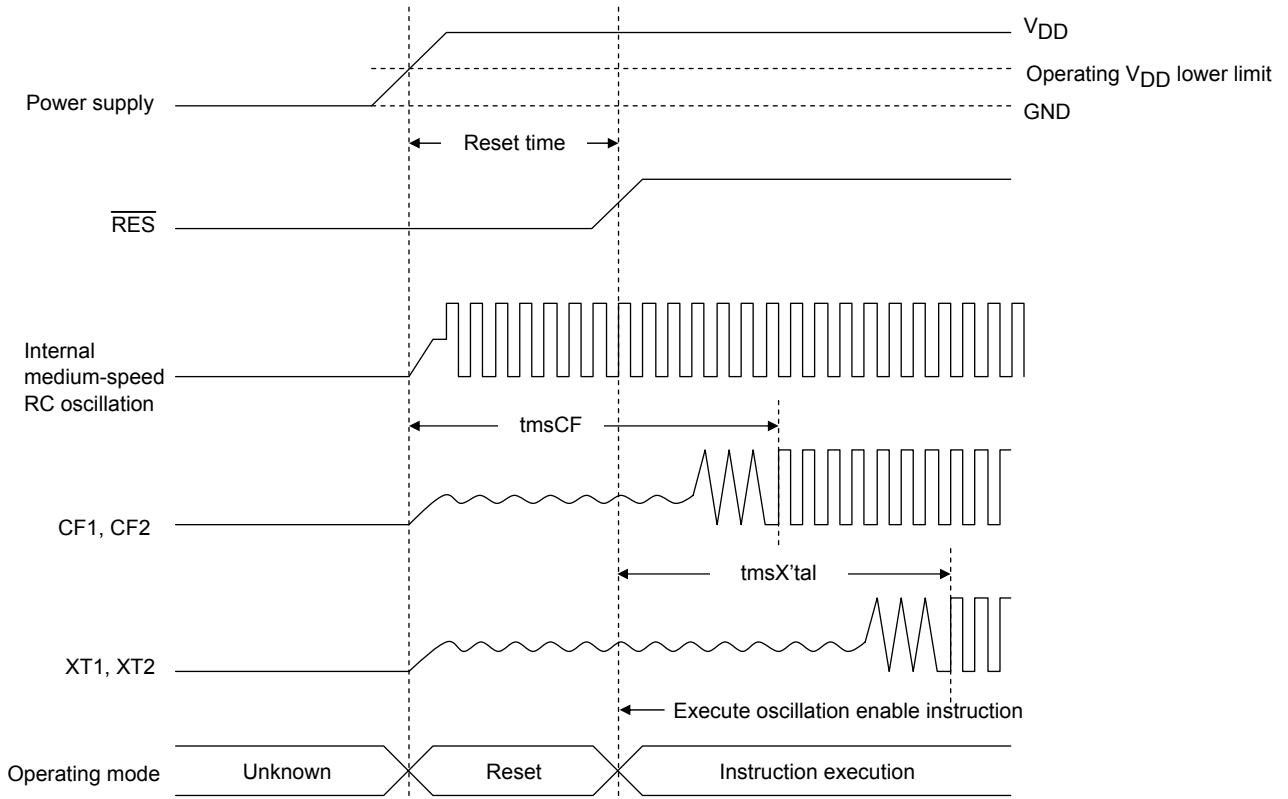
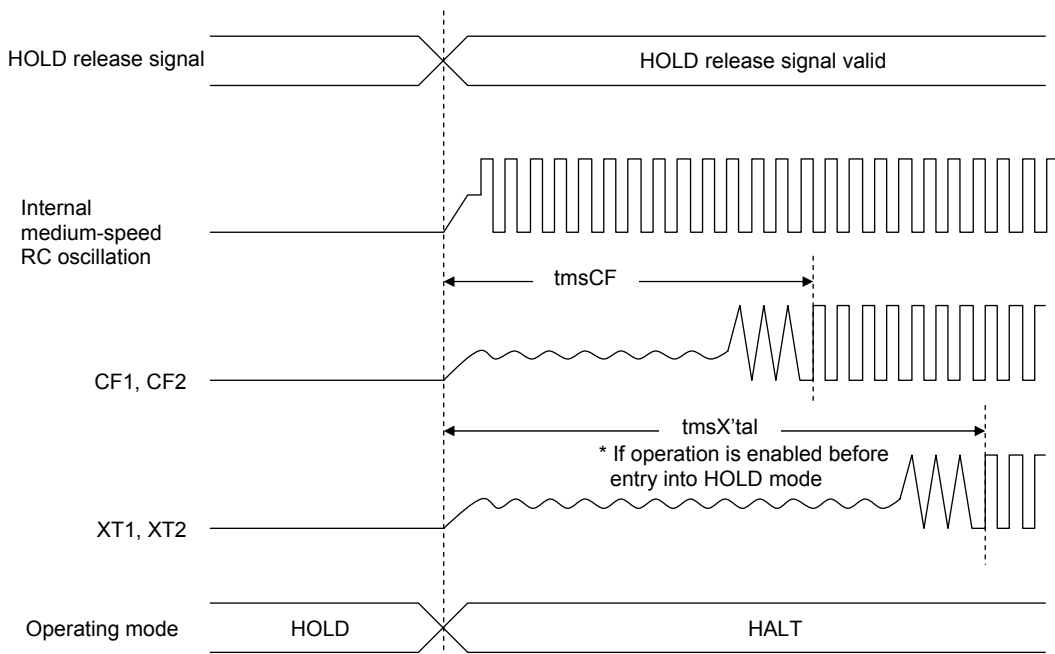

Figure 3 AC Timing Measurement Point



Reset Time and Oscillation Stabilization Time



HOLD Release Signal and Oscillation Stabilization Time

Figure 4 Oscillation Stabilization Time

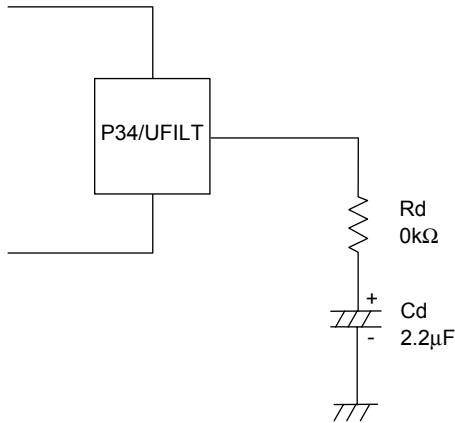

When using the internal PLL circuit to generate the 48MHz clock for USB, it is necessary to connect a filter circuit as shown in the left figure to the P34/UFILT pin. After PLL is set, stabilization time of 20ms or longer must be secured.

Figure 5 External Filter Circuit for the Internal USB-dedicated PLL Circuit

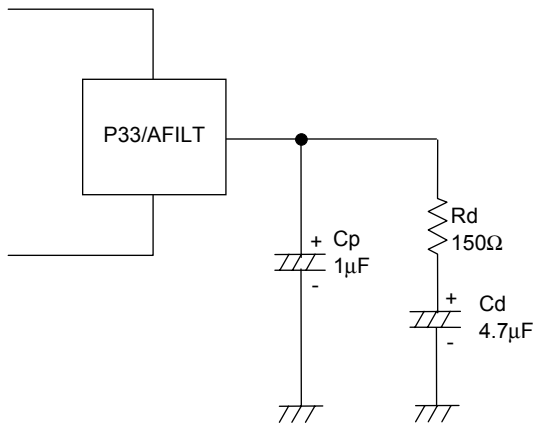

To generate the master clock for the audio interface using the internal PLL circuit, it is necessary to connect a filter circuit as shown in the left figure to the P33 pin.

Figure 6 External Filter Circuit for Audio Interface (Used with Internal PLL Circuit)

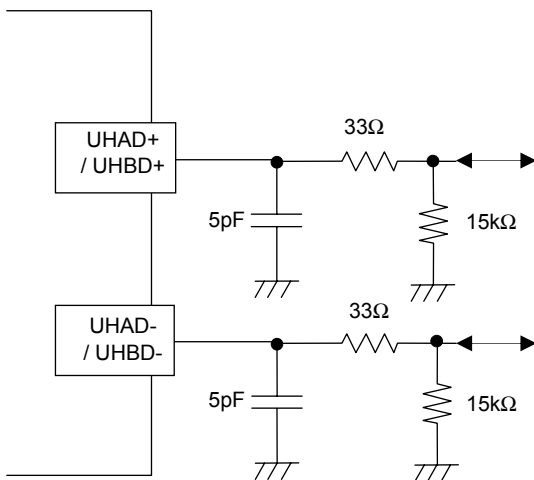

It is necessary to adjust the circuit constant of the USB port peripheral circuit for each mounting board.

Figure 7 USB Port Peripheral Circuit

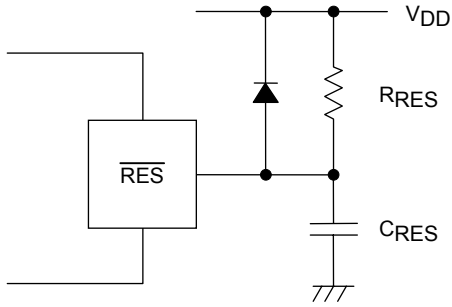

Note:
The external circuit differs depending on which of the power-on reset and low-voltage reset functions is to be used. Refer to the section on the reset functions in the user's manual.

Figure 8 Sample Reset Circuit

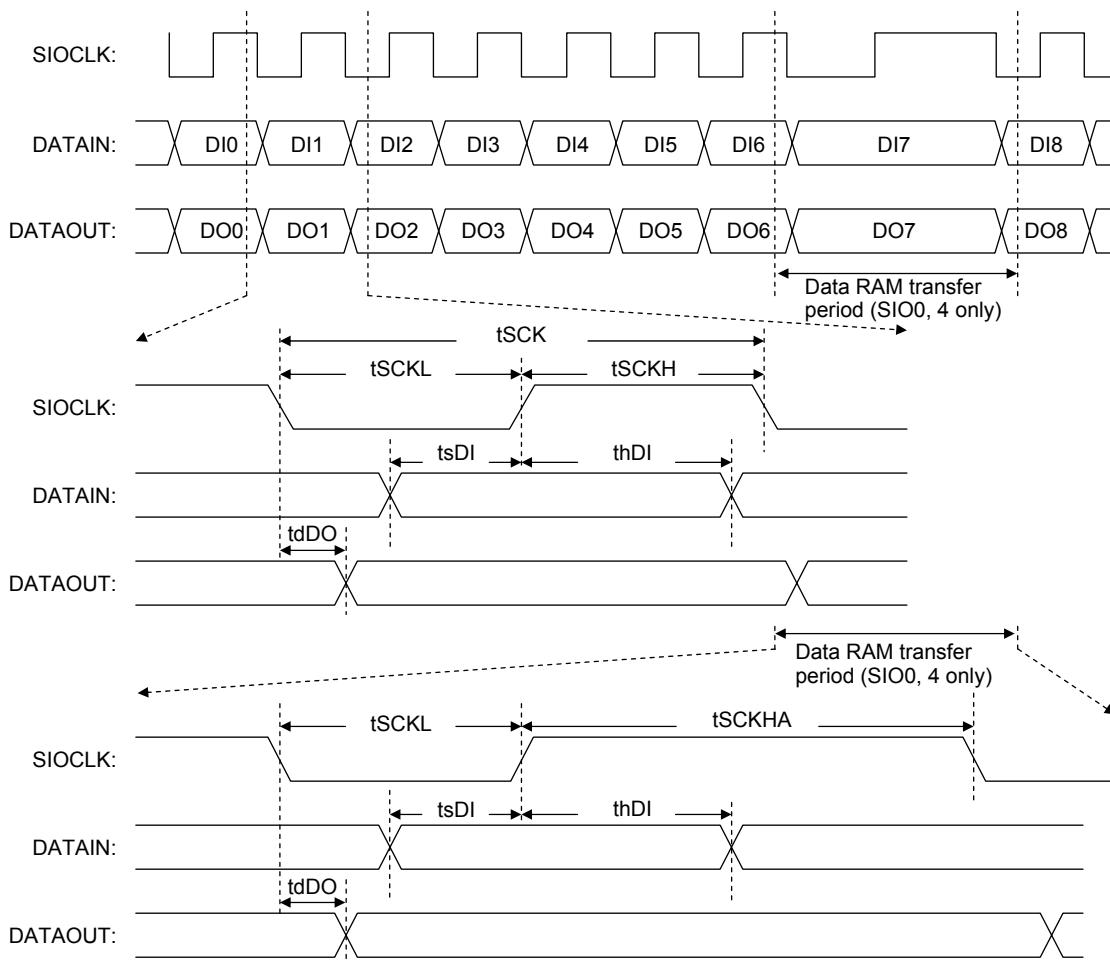

Figure 9 Serial I/O Waveform

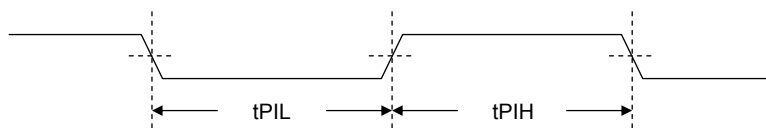

Figure 10 Pulse Input Timing Waveform

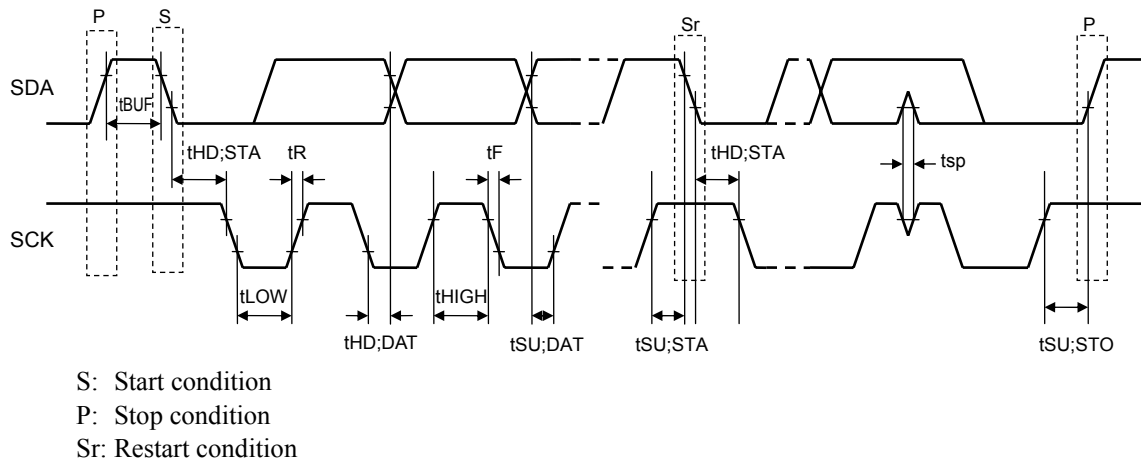

Figure 11 I²C Timing

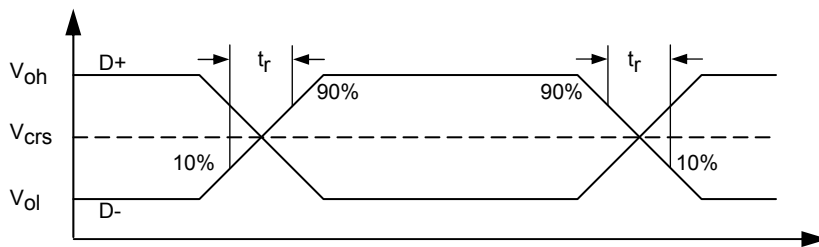

Figure 12 USB Data Signal Timing and Voltage Levels

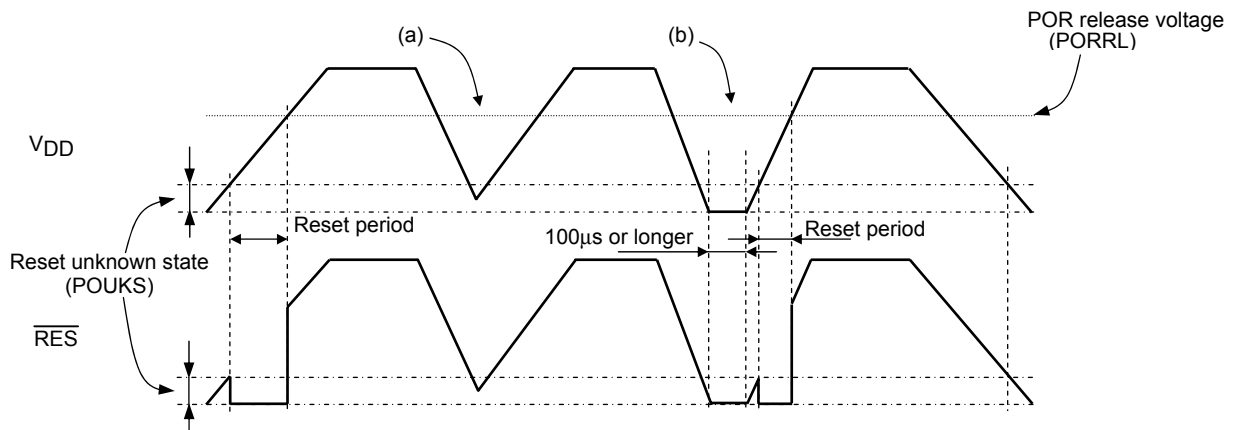

Figure 13 Sample Waveforms for POR-only (LVD deselected) Operation (Reset pin: Pull-up resistor PRES only)

- The POR function generates a reset only when the power is turned on starting at the V_{SS} level.
- No stable reset will be generated if power is turned on again if the power level does not go down to the V_{SS} level as shown in (a). If such a case is anticipated, use the LVD function together with the POR function as explained below or implement an external reset circuit.
- A reset is generated only when power level goes down to the V_{SS} level as shown in (b) and power is turned on again after this condition continues for 100 μ s or longer.

LC87F1K64A

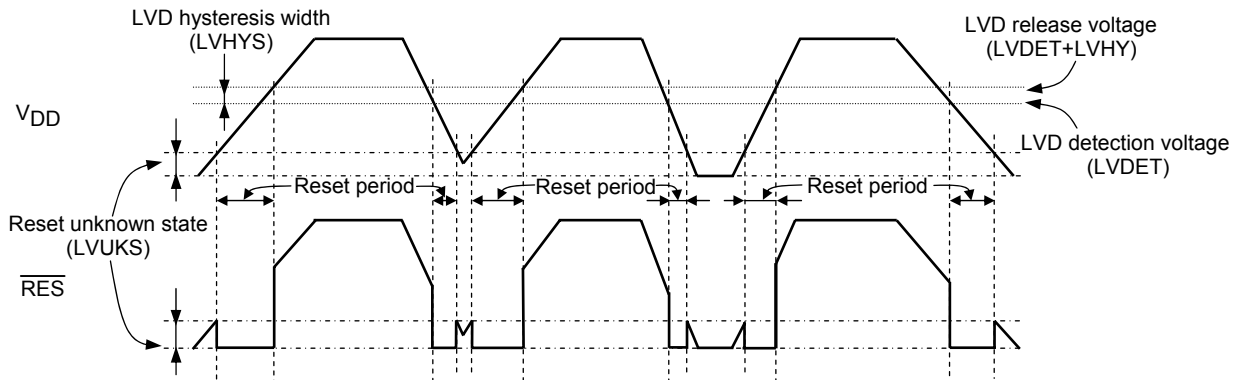

Figure 14 Sample Waveforms for POR+LVD Operation (Reset pin: Pull-up Resistor PRES Only)

- A reset is generated both when power is turned on and when the power level lowers.
- A hysteresis width (LVHYS) is provided to prevent repetitions of reset release and entry cycles near the detection level.

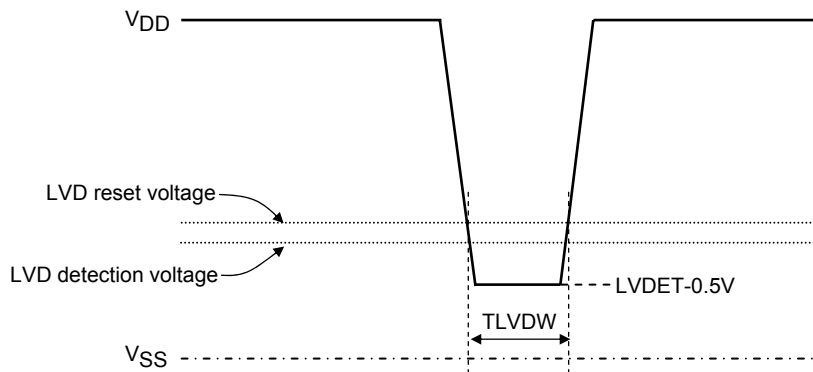

Figure 15 Minimum Low Voltage Detection Width (Sample Temporary Power Interruption/Fluctuation Waveform)

ORDERING INFORMATION

Device	Package	Shipping (Qty / Packing)
LC87F1K64AUWA-2H	SQFP48(7X7) (Pb-Free / Halogen Free)	250 / Tray Foam

ON Semiconductor and the ON logo are registered trademarks of Semiconductor Components Industries, LLC (SCILLC). SCILLC owns the rights to a number of patents, trademarks, copyrights, trade secrets, and other intellectual property. A listing of SCILLC's product/patent coverage may be accessed at www.onsemi.com/site/pdf/Patent-Marking.pdf. SCILLC reserves the right to make changes without further notice to any products herein. SCILLC makes no warranty, representation or guarantee regarding the suitability of its products for any particular purpose, nor does SCILLC assume any liability arising out of the application or use of any product or circuit, and specifically disclaims any and all liability, including without limitation special, consequential or incidental damages. "Typical" parameters which may be provided in SCILLC data sheets and/or specifications can and do vary in different applications and actual performance may vary over time. All operating parameters, including "Typicals" must be validated for each customer application by customer's technical experts. SCILLC does not convey any license under its patent rights nor the rights of others. SCILLC products are not designed, intended, or authorized for use as components in systems intended for surgical implant into the body, or other applications intended to support or sustain life, or for any other application in which the failure of the SCILLC product could create a situation where personal injury or death may occur. Should Buyer purchase or use SCILLC products for any such unintended or unauthorized application, Buyer shall indemnify and hold SCILLC and its officers, employees, subsidiaries, affiliates, and distributors harmless against all claims, costs, damages, and expenses, and reasonable attorney fees arising out of, directly or indirectly, any claim of personal injury or death associated with such unintended or unauthorized use, even if such claim alleges that SCILLC was negligent regarding the design or manufacture of the part. SCILLC is an Equal Opportunity/Affirmative Action Employer. This literature is subject to all applicable copyright laws and is not for resale in any manner.