

Quad Differential Comparators

◆ Description

The ET-LM339 consists of four independent voltage comparators. These were designed specifically to operate from a single power supply over a wide range of voltages. Operation from split power supplies is also possible and the low power supply current drain is independent of the magnitude of the power supply voltage. The outputs can be connected to other open-collector outputs to achieve wired-AND relationships.

◆ Features

- Wide Supply Voltage Range.
- Low Supply Current Drain Independent Of Supply Voltage.
- Low Input Biasing Current.
- Low Input Offset Current.
- Low Input Offset Voltage.
- Input Common-mode Voltage Range Includes GND.
- Differential Input Voltage Range Equal To The Power Supply Voltage.
- Low Output Saturation Voltage.
- Output Voltage Compatible With TTL, MOS and CMOS Logic.

◆ Pin Description

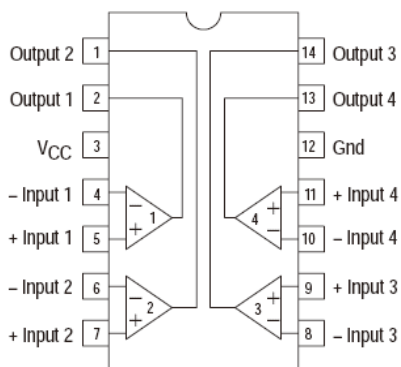

(Top View)

SOP-14

DIP-14

◆ Applications

- Battery Charger
- Cordless Telephone
- Switching Power Supply
- DC-DC Module
- Motherboard
- Communication Equipment

◆ Ordering Information

Part Number	Operating Temperature Range	Package	Packing
LM339KI	-40 °C ~ +125 °C	SOP-14	Tape & Reel
LM339JI		DIP-14	Tube

◆ Absolute Maximum Ratings

Symbol	Parameter	Value	Unit
V _{CC}	Power Supply Voltages	+36 or ±18	V
V _{IDR}	Input Differential Voltage Range	36	V
V _{ICR}	Input Common Mode Voltage Range	-0.3 ~ +36	V
T _J	Junction Temperature	150	°C
T _{STG}	Storage Temperature (T _A =+25°C)	-60~150	°C
T _L	Lead Temperature, 1mm from Case for 10 Senconds	260	°C

◆ Thermal Characteristics

Symbol	Parameter	Package	Typical Value	Unit
θ _{JA}	Thermal Resistance From Junction to Ambient in Free Air. (Measured with the component mounted on a high effective thermal conductivity test board in free air.)	SOP-14	160	°C/W
		DIP-14	125	

◆ Electrical Characteristics ($T_A=25\text{ }^\circ\text{C}$, $V_{CC}=5.0\text{V}$, unless otherwise noted.)

Symbol	Parameter	Test Condition *		Min.	Typ.	Max.	Unit	
V_{IO}	Input Offset Voltage	$V_{CC}=5\text{V to }30\text{V}$ $V_{IC}=V_{ICR\text{ min}}$ $V_O=1.4\text{V}$	$25\text{ }^\circ\text{C}$	-	2.0	5.0	mV	
			Full Range	-	-	9.0		
I_{IO}	Input Offset Current	$V_O=1.4\text{V}$	$25\text{ }^\circ\text{C}$	-	2	50	nA	
			Full Range	-	-	150		
I_{IB}	Input Bias Current	$V_O=1.4\text{V}$	$25\text{ }^\circ\text{C}$	-	-25	-250	nA	
			Full Range	-	-	-400		
V_{ICR}	Common-mode Input Voltage Range **		$25\text{ }^\circ\text{C}$	-	-	$V_{CC}-1.5$	V	
			Full Range	-	-	$V_{CC}-2.0$		
A_{VD}	Large-signal Differential Voltage Amplification	$V_{CC}=15\text{V}$, $R_L \geq 15\text{k}\Omega$ $V_O=1.4\text{V to }11.4\text{V}$	$25\text{ }^\circ\text{C}$	50	200	-	mV/V	
I_{OH}	High-Level Output Current	$V_{CC}=15\text{V}$, $V_{ID}=1\text{V}$	$25\text{ }^\circ\text{C}$	-	0.1	50	mA	
		$V_{CC}=30\text{V}$, $V_{ID}=1\text{V}$	Full Range	-	-	1		
V_{OL}	High-Level Output Voltage	$I_{OL}=4\text{mA}$, $V_{ID}=-1.0\text{V}$	$25\text{ }^\circ\text{C}$	-	150	400	mV	
			Full Range	-	-	700		
I_{OL}	Low-Level Output Current	$V_{OL}=1.5\text{V}$, $V_{ID}=-1.0\text{V}$	$25\text{ }^\circ\text{C}$	6.0	-	-	mA	
I_{CC}	Supply Current	$R_L=\infty$	$V_{CC}=5.0\text{V}$	$25\text{ }^\circ\text{C}$	-	0.8	1.0	mA
			$V_{CC}=30\text{V}$	Full Range	-	1	2.5	mA

* Full range (Min. to Max.) is $-40\text{ }^\circ\text{C}$ to $+125\text{ }^\circ\text{C}$, All characteristics are measured with zero common-mode input voltage unless otherwise specified.

** The voltage at either input or common-mode should not be allowed to go negative by more than 0.3V. The upper end of the common-mode voltage range is $V_{CC}-1.5\text{V}$, but either or both inputs can go to 30V without damage.

◆ Switching Characteristics ($V_{CC}=5\text{V}$, $T_A=25\text{ }^\circ\text{C}$)

Parameter	Test Conditions		Min.	Typ.	Max.	Unit
Response time	RL connected to 5V through 5.1k Ω , CL=15pF * (See Note 1)	100-mV input step with 5-mV overdrive	-	1.3	-	uS
		TTL-Level input step	-	0.3	-	

* C_L includes probe and jig capacitance.

Note 1: The response time specified is the interval between the input step function and the instant, When the output crosses 1.4V.

◆ **Typical Characteristics**

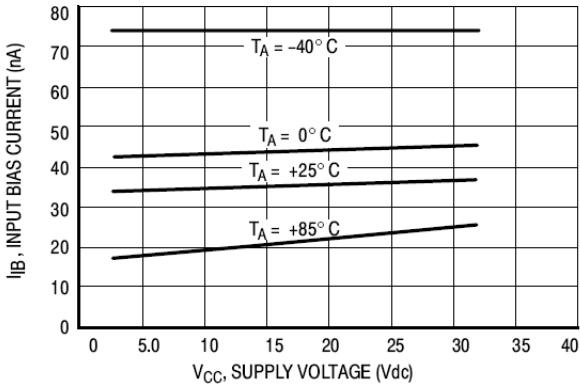

Figure 1. Input Bias Current versus Power Supply Voltage

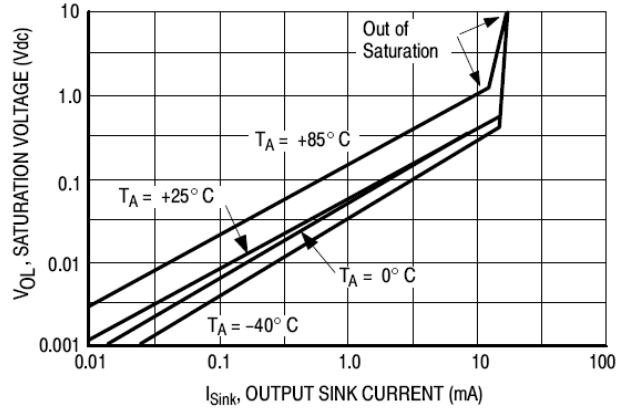

Figure 2. Output Saturation Voltage versus Output Sink Current

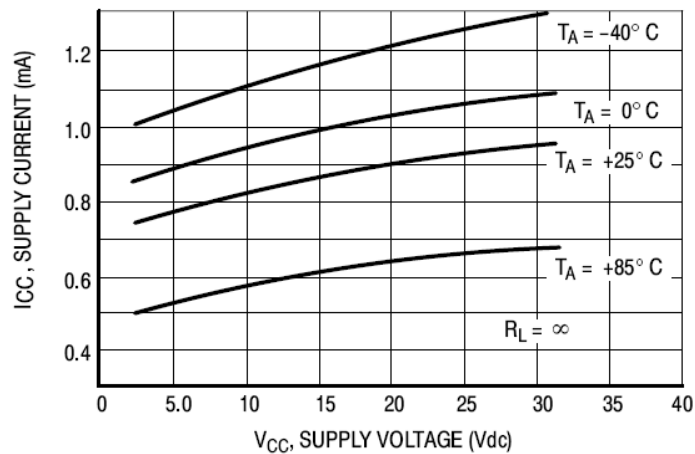
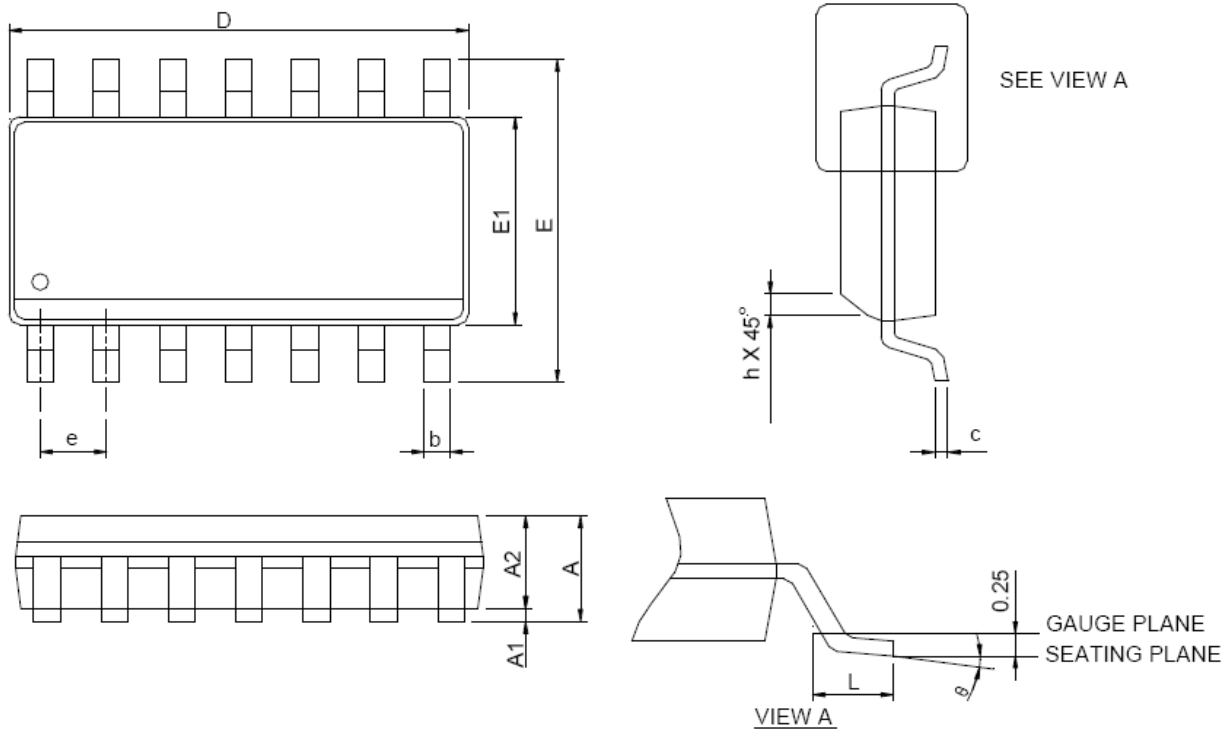

Figure 3. Power Supply Current versus Power Supply Voltage

◆ Package Information

SOP-14



SYMBOL	SOP-14			
	MILLIMETERS		INCHES	
	MIN.	MAX.	MIN.	MAX.
A		1.75		0.069
A1	0.10	0.25	0.004	0.010
A2	1.25		0.049	
b	0.31	0.51	0.012	0.020
c	0.17	0.25	0.007	0.010
D	8.55	8.75	0.337	0.344
E	5.80	6.20	0.228	0.244
E1	3.80	4.00	0.150	0.157
e	1.27 BSC		0.050 BSC	
h	0.25	0.50	0.010	0.020
L	0.40	1.27	0.016	0.050
θ	0°	8°	0°	8°

◆ Package Information

DIP-14

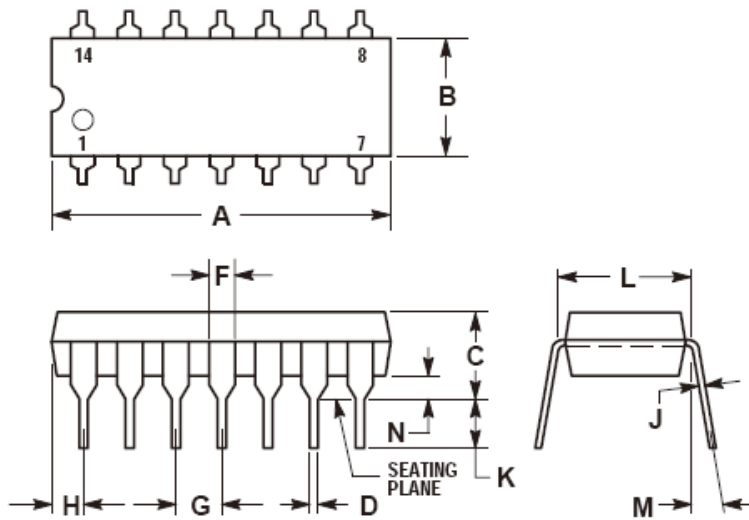

SYMBOL	DIP-14			
	MILLIMETERS		INCHS	
	MIN.	MAX.	MIN.	MAX.
A	18.16	19.56	0.715	0.770
B	6.10	6.60	0.240	0.260
C	3.69	4.69	0.145	0.185
D	0.38	0.53	0.015	0.021
F	1.02	1.78	0.040	0.070
G	2.54BSC		0.100BSC	
H	1.32	2.41	0.052	0.095
J	0.20	0.38	0.008	0.015
K	2.92	3.43	0.115	0.135
L	7.62BSC		0.300BSC	
M	0°	10°	0°	10°
N	0.39	1.01	0.015	0.039