

Specification Control Drawing

Grade L Devices

For Space Application

= Hi-Rel Silicon Device =

Prepared on : December 16, 2002

NEC Compound Semiconductor Devices, Ltd.

Table of Contents

1. Introduction	
2. Grade L Available Part List	Table 1
3. Bipolar Transistor	
Typical Screening Flow For Grade L	Fig.1
Preconditioning and Screening For Grade L	Table 2
Absolute Maximum Ratings	Table 3
Electrical Characteristics Group A	Table 4
Delta Criteria	Table 5
4. SiMMICs	
Typical Screening Flow For Grade L	Fig.2
Preconditioning and Screening For Grade L	Table 6
Absolute Maximum Ratings	Table 7
Electrical Characteristics Group A	Table 8
Delta Criteria	Table 9
5. Package (Dimensions, Marking, Lead Connections)	
6. Chip (Pad Connections, Chip Drawings)	

INTRODUCTION

NEC has decided to introduce a new reliability grade for Satellite applications, Grade L Microwave semiconductors.

The emerging markets of commercial satellites for satellite-based digital communications systems, require low cost, high reliability and shorter TAT. To comply with such requests, Grade L devices with reduced screening and Inspection to MIL-PRF-19500 and MIL-PRF-38535 have been developed. This is based on NEC outstanding quality experience in Hi-Rel history.

Grade L devices are characterized by the following items:

- 1) Customer Source Inspection (CSI) is not applicable.
- 2) Test report is not deliverable. When customer absolutely needs test data, it will be available with an additional cost, but limited to four kinds of data:
 - a) Summary Sheet
 - b) Bond STRENGTH Test Data
 - c) Power Burn-in Delta Data
 - d) Group A Test Data (RF is Sampling basis or 100%)
- 3) Grade L is available to the parts limited to the attached list.
(Grade L Available Part List)
- 4) Lot Assurance Tests (QCI Tests) are not applicable.
- 5) High or low temperature test is not applicable.

Table 1 Grade L Available Part List

Bipolar Transistor (Small signal)		NE02100(L)	** NE02103(L)
			NE02107(L)
		NE41600(L)	** NE41603(L)
			NE41607(L)
		** NE68000(L)	** NE68008(L)
		NE68100(L)	NE68108(L)
		** NE73400(L)	** NE73408(L)
		NE85600(L)	NE85608(L)
		* NE89400(L)	*NE89407(L)
			*NE89408(L)
SiMMIC	Amplifier	** UPC1677P(L)	** UPC1677B(L)
		** UPC1678P(L)	** UPC1678B(L)
		** UPC2708P(L)	** UPC2708B(L)
		UPC2709P(L)	UPC2709B(L)
		** UPC2710P(L)	** UPC2710B(L)
		UPC2711P(L)	UPC2711B(L)
		UPC2712P(L)	UPC2712B(L)
		UPC2713P(L)	UPC2713B(L)
		** UPC2726P(L)	** UPC2726B(L)
Prescaler	UPB1508P(L)	UPB1508B(L)	
	UPB1509P(L)	UPB1509B(L)	
	UPB1510P(L)	UPB1510B(L)	
Convertor	**UPC2758P(L)	**UPC2758B(L)	
	**UPC8106P(L)	**UPC8106B(L)	

* New release

**To be phased out

SiTr PKG.

Fig. 1-1 Screening Flow SiTr PKG.

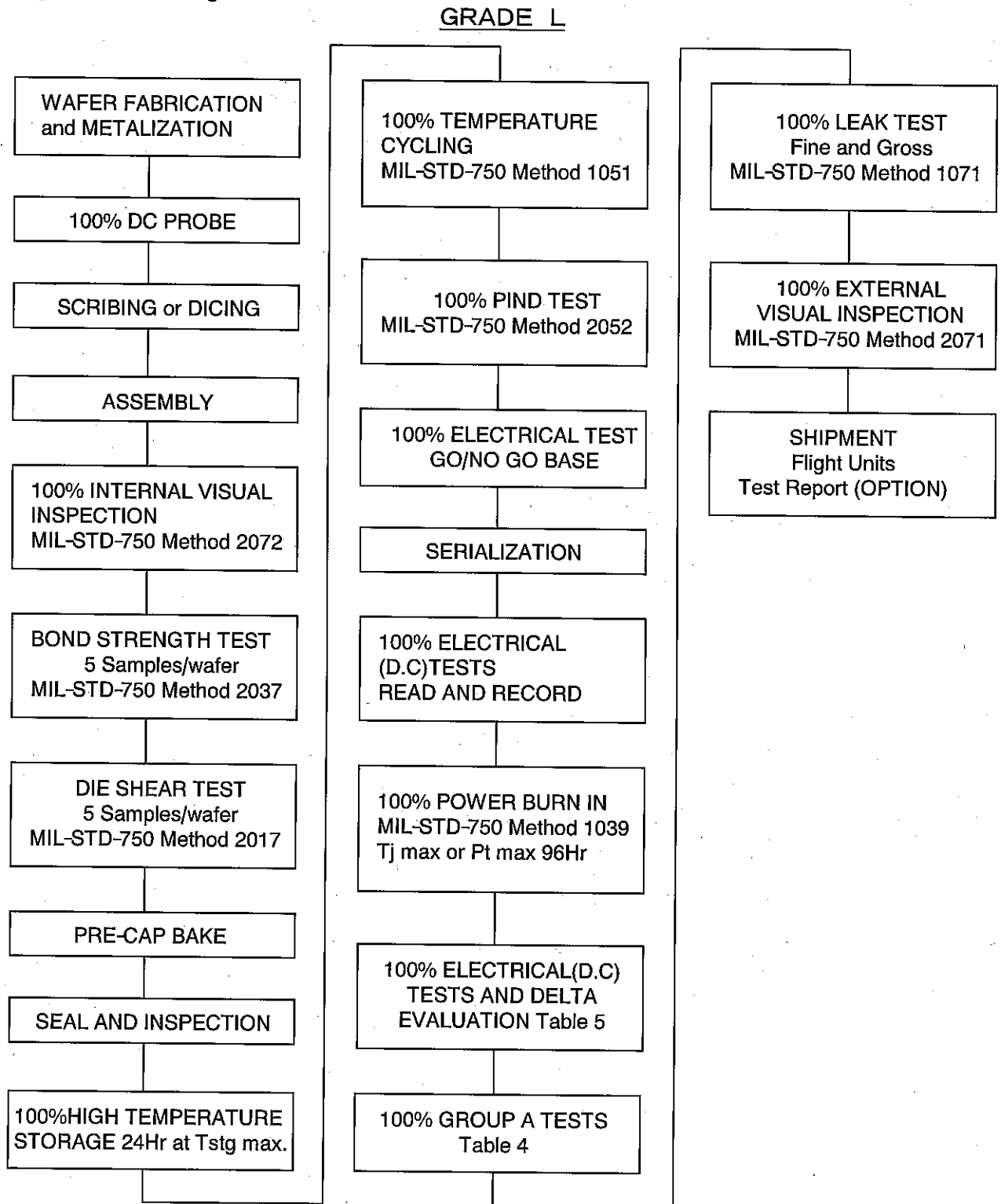

Note Test report (option) includes the following Summary Sheet.
 Bond Strength Test Data.
 Power Burn-in Delta Data.
 Group A Test Data.

SiTr CHIPS

Fig. 1-2 Screening Flow SiTr Chips

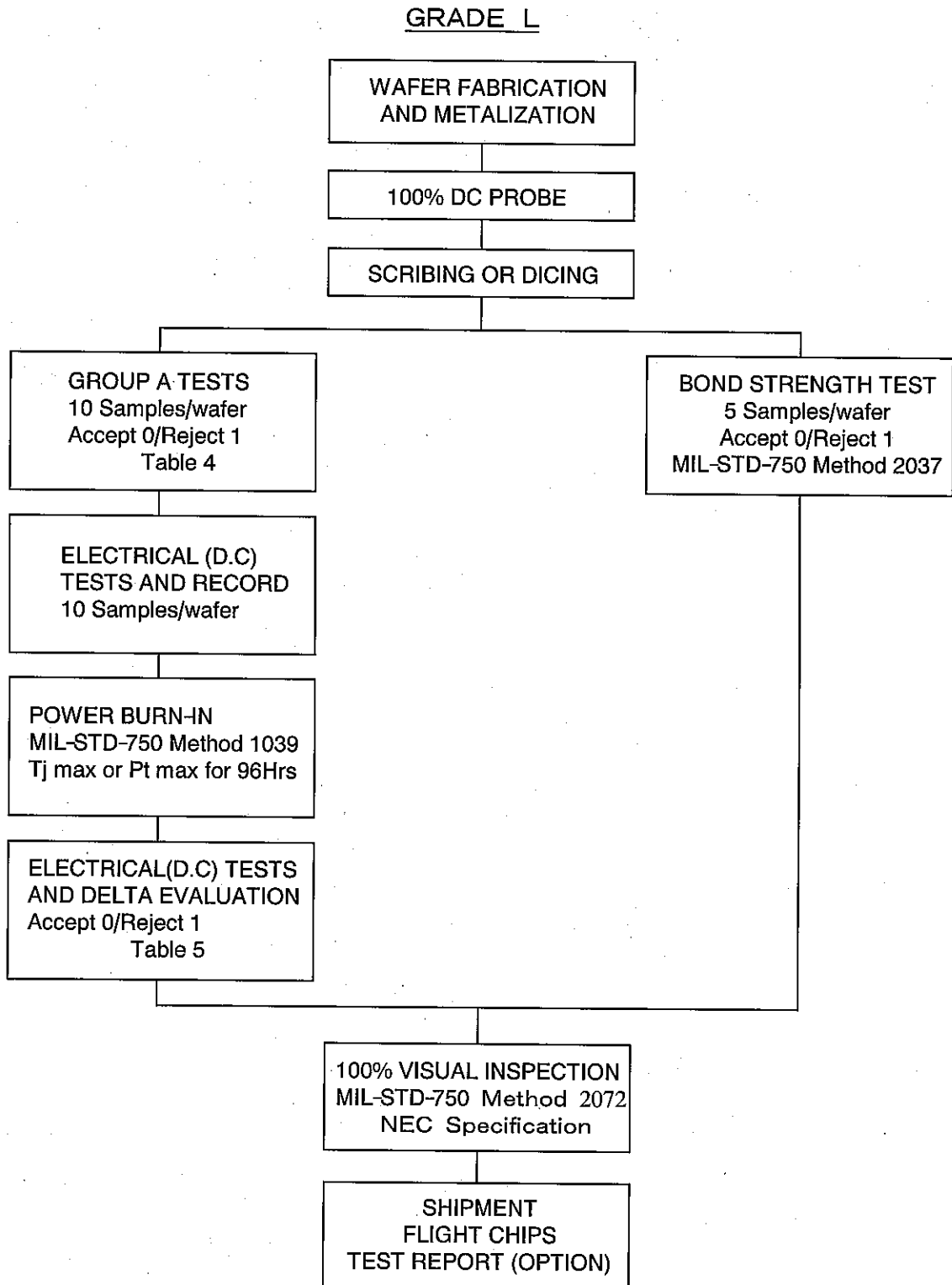

Note Test report (option) includes the following Summary Sheet.
 Bond Strength Test Data.
 Power Burn-in Delta Data.
 Group A Test Data.

Table 2 Preconditioning and Screening for Bipolar Transistors

EXAMINATION OR TEST	MIL-STD 750 METHOD	CONDITION	RELIABILITY GRADE L
Bond Strength Test	2037	Record Data	n=5
Die Shear Test	2017	Samples subjected to the bond strength test shall be used for this test Record data	n=5
Internal Visual (Pre-cap) Inspection	2072	NEC Specification	100%
Pre cap Bake	—	2Hrs at 300°C	100%
High Temperature Storage	1032	24Hrs min. at T STG. Max.	100%
Temperature Cycling	1051	Condition C, 20 cycles 100%	100%
PIND Test	2052	Condition A,	100%
Serialization	—		100%
Electrical Test	3001D 3026D 3076	Per data sheet limit Record data Per Table 4	100%
Power Burn-in	1039	Condition B, Tj max,PT max 96Hrs min.	100%
Electrical Test and Delta Parameter	3001D 3026D 3076	Per data sheet limit and Table 5 Record data	100%
Group A Test	—	Table 4	100% Note.
Hermetic Fine Leak Gross Leak	1071	Condition H 5×10^{-9} Pa m ³ /sec.Max. Condition C,	100%
External Visual Inspection	2071		100%

Note) DC 100%, RF is Sampling Basis or 100%, depending on the parts.

Table 3 - 1 Absolute Maximum Ratings

Ta=25°C

Part No	Symbols	Parameters	Ratings	Units
NE02100(L) NE02103(L) NE02107(L) NE02108(L)	V _{CB0}	Collector to Base Voltage	25	V
	V _{CE0}	Collector to Emitter Voltage	12	V
	V _{EB0}	Emitter to Base Voltage	3	V
	I _c	Collector Current	70	mA
	T _j	Junction Temperature	200	°C
	T _{STG.}	Storage Temperature	-65~+200	°C
	R _{th(j-c)}		70(-00,-03) 90(-07,-08)	°C/W
NE41600(L) NE41603(L) NE41607(L)	V _{CB0}	Collector to Base Voltage	35	V
	V _{CE0}	Collector to Emitter Voltage	18	V
	V _{EB0}	Emitter to Base Voltage	3	V
	I _c	Collector Current	100	mA
	T _j	Junction Temperature	200	°C
	T _{STG.}	Storage Temperature	-65~+200	°C
	R _{th(j-c)}		50(-00,-03,-07)	°C/W
NE68000(L) NE68008(L)	V _{CB0}	Collector to Base Voltage	20	V
	V _{CE0}	Collector to Emitter Voltage	10	V
	V _{EB0}	Emitter to Base Voltage	1.5	V
	I _c	Collector Current	35	mA
	T _j	Junction Temperature	200	°C
	T _{STG.}	Storage Temperature	-65~+200	°C
	R _{th(j-c)}		80(-00) 100(-08)	°C/W
NE68100(L) NE68108(L)	V _{CB0}	Collector to Base Voltage	20	V
	V _{CE0}	Collector to Emitter Voltage	10	V
	V _{EB0}	Emitter to Base Voltage	1.5	V
	I _c	Collector Current	65	mA
	T _j	Junction Temperature	200	°C
	T _{STG.}	Storage Temperature	-65~+200	°C
	R _{th(j-c)}		80(-00) 110(-08)	°C/W

Table 3 - 2 Absolute Maximum Ratings

Ta=25°C

Part No	Symbols	Parameters	Ratings	Units
NE73400(L) NE73408(L)	V _{CBO}	Collector to Base Voltage	30	V
	V _{CEO}	Collector to Emitter Voltage	14	V
	V _{EBO}	Emitter to Base Voltage	3	V
	I _c	Collector Current	50	mA
	T _j	Junction Temperature	200	°C
	T _{STG.}	Storage Temperature	-65~+200	°C
	R _{th(j-c)}		90(-00) 110(-08)	°C/W
NE85600(L) NE85608(L)	V _{CBO}	Collector to Base Voltage	20	V
	V _{CEO}	Collector to Emitter Voltage	12	V
	V _{EBO}	Emitter to Base Voltage	3.0	V
	I _c	Collector Current	100	mA
	T _j	Junction Temperature	200	°C
	T _{STG.}	Storage Temperature	-65~+200	°C
	R _{th(j-c)}		80(-00) 100(-08)	°C/W
NE89400(L) NE89407(L) NE89408(L)	V _{CBO}	Collector to Base Voltage	9.0	V
	V _{CEO}	Collector to Emitter Voltage	3.0	V
	V _{EBO}	Emitter to Base Voltage	1.5	V
	I _c	Collector Current	35	mA
	T _j	Junction Temperature	200	°C
	T _{STG.}	Storage Temperature	-65~+200	°C
	R _{th(j-c)}		80(-00) 120(-07,-08)	°C/W

Table 4 - 1 Electrical Characteristics : Group A

Ta=25°C

Part No	Parameter	Test Condition	Limits		Units
NE02100(L) NE02103(L) NE02107(L) NE02108(L)	ICBO	VCB=15V IE=0	—	1	uA
	IEBO	VEB=2V IC=0	—	1	uA
	hFE	VCE=10V IC=20mA	20	250	—
	C _{CB}	VCB=10V IE=0 f=1MHz	—	1	pF
	S _{21E} ²	VCE=10V IC=20mA f=1GHz	11	—	dB
	NF	VCE=10V IC=5mA f=1GHz	—	3.5	dB
NE41600(L) NE41603(L) NE41607(L)	ICBO	VCB=20V IE=0	—	0.1	uA
	IEBO	VEB=2V IC=0	—	0.1	uA
	hFE	VCE=10V IC=50mA	30	200	—
	C _{CB}	VCB=10V IE=0 f=1MHz	—	2	pF
	S _{21E} ²	VCE=10V IC=30mA f=1GHz	7	—	dB
	NF	VCE=10V IC=5mA f=1GHz	—	4	dB
NE68000(L) NE68008(L)	ICBO	VCB=10V IE=0	—	1	uA
	IEBO	VEB=1V IC=0	—	1	uA
	hFE	VCE=6V IC=10mA	50	250	—
	C _{CB}	VCB=10V IE=0 f=1MHz	—	0.7	pF
	S _{21E} ²	VCE=6V IC=10mA f=2GHz	10.5	—	dB
	NF	VCE=6V IC=5mA f=2GHz	—	2.4	dB
NE68100(L) NE68108(L)	ICBO	VCB=10V IE=0	—	1	uA
	IEBO	VEB=1V IC=0	—	1	uA
	hFE	VCE=8V IC=20mA	50	200	—
	C _{CB}	VCB=10V IE=0 f=1MHz	—	0.7	pF
	S _{21E} ²	VCE=8V IC=20mA f=2GHz	9	—	dB
	NF	VCE=8V IC=7mA f=2GHz	—	2.3	dB

Table 4 - 2 Electrical Characteristics : Group A

Ta=25°C

Part No	Parameter	Test Condition	Limits		Units
NE73400(L) NE73408(L)	I _{CBO}	V _{CB} =15V I _E =0	—	0.1	μA
	I _{EBO}	V _{EB} =2V I _C =0	—	0.1	μA
	h _{FE}	V _{CE} =10V I _C =10mA	25	200	—
	C _{CB}	V _{CB} =10V I _E =0 f=1MHz	—	1.5	pF
	S _{21E} ²	V _{CE} =10V I _C =10mA f=1GHz	8	—	dB
	NF	V _{CE} =10V I _C =3mA f=0.5GHz	—	3.5	dB
NE85600(L) NE85608(L)	I _{CBO}	V _{CB} =15V I _E =0	—	1	μA
	I _{EBO}	V _{EB} =1V I _C =0	—	1	μA
	h _{FE}	V _{CE} =10V I _C =20mA	50	300	—
	C _{CB}	V _{CB} =10V I _E =0 f=1MHz	—	1	pF
	S _{21E} ²	V _{CE} =10V I _C =20mA f=2GHz	7	—	dB
	NF	V _{CE} =10V I _C =7mA f=2GHz	—	3.4	dB
NE89400(L) NE89407(L) NE89408(L)	I _{CBO}	V _{CB} =5V I _E =0	—	0.1	μA
	I _{EBO}	V _{EB} =1V I _C =0	—	0.1	μA
	h _{FE}	V _{CE} =1V I _C =5mA	50	100	—
	C _{re}	V _{CB} =0.5V I _E =0 f=1MHz	—	1	pF
	S _{21E} ²	V _{CE} =1V I _C =20mA f=2GHz	10	—	dB
	NF	V _{CE} =1V I _C =5mA f=2GHz	—	2.5	dB

Table 5 Delta Parameters and Criteria Screening of Bipolar Transistors

Symbol	Maximum Allowable Delta for Power Burn-in	
	Grade L	Small Signal
ICBO	+10nA	or +100% *
IEBO	+10nA	or +100% *
hFE	$\pm 15\%$	

*Whichever is greater.

SiMMIC PKG.

Fig. 2-1 Screening Flow SiMMIC

GRADE L

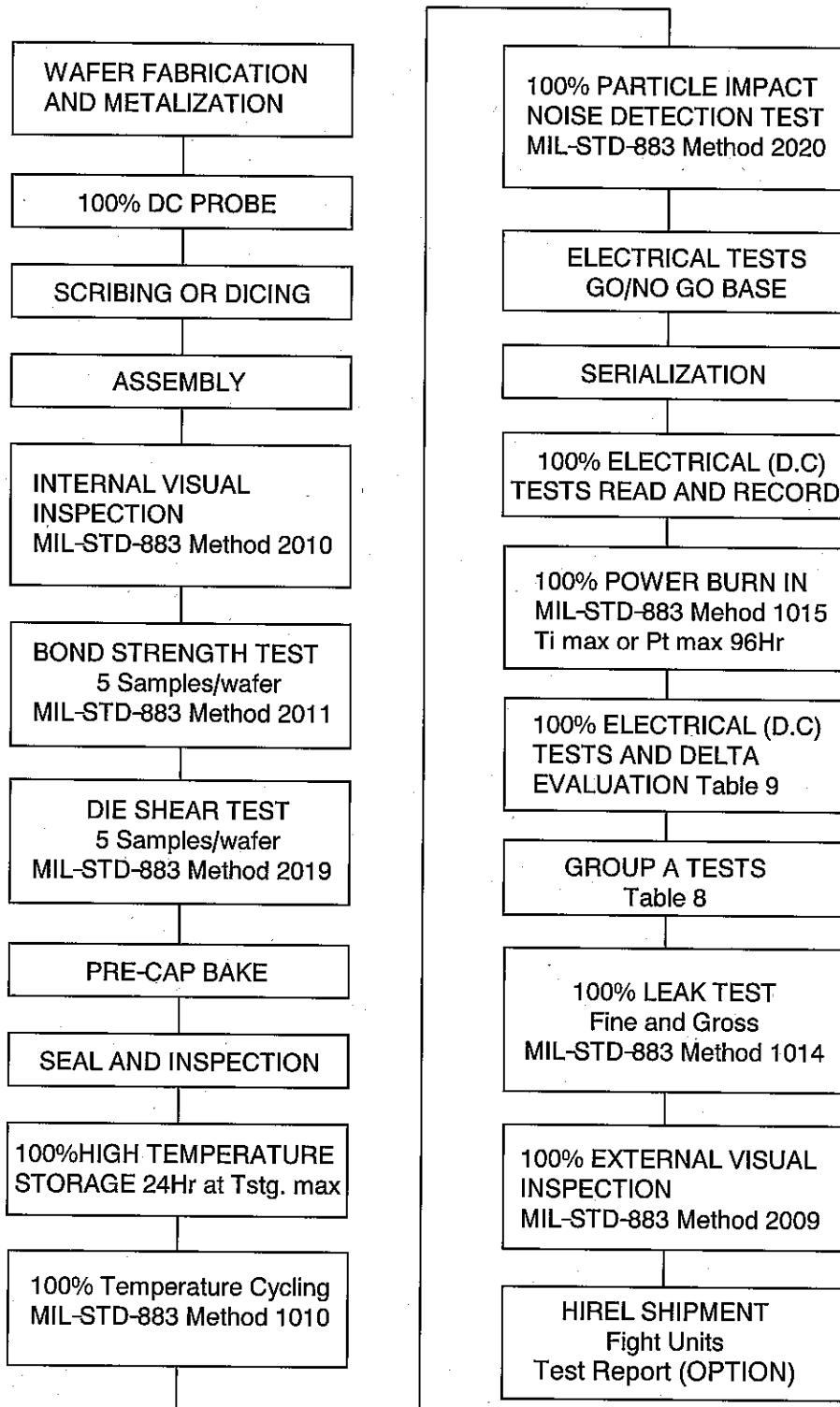

Note Test report (option) includes the following Summary Sheet.
 Bond strength Test Data.
 Power Burn-in Delta Data.
 Group A Test Data.

SIMMIC CHIPS

Fig. 2-2 Screening Flow SiMMIC Chips

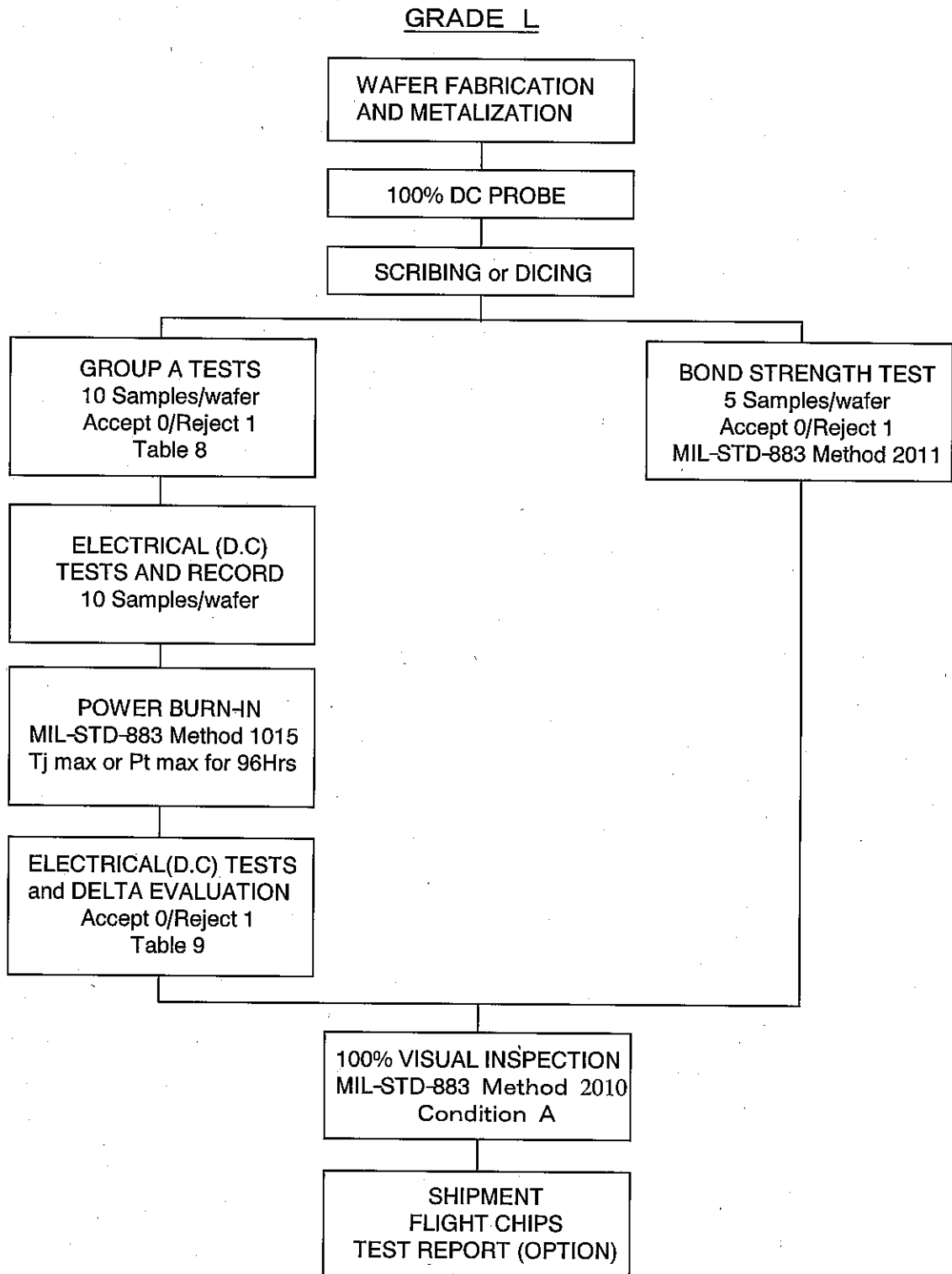

Note Test report (option) includes the following
 Summary Sheet.
 Bond strength Test Data.
 Power Burn-in Delta Data.
 Group A Test Data.

Table 6 Preconditioning and Screening for Packaged Silicon MMICs

EXAMINATION OR TEST	MIL-STD 883 METHOD	CONDITION	RELIABILITY GRADE L
Bond Strength Test	2011	Condition D	n=5
Die Shear Test	2019		n=5
Internal Visual (Pre-cap) Inspection	2010	Condition B	100%
Pre Cap Bake	—	2Hr Ta=200°C	100%
High Temperature Storage	1008	24Hrs at Ta=200°C	100%
Temperature Cycling	1010	Condition D -65°C to +200°C	100%
PIND Test	2020	Condition A	100%
Serialization	—		100%
Electrical Test	—	Table 8	100%
Power Burn-in	1015	Condition B Ta=125°C 96Hrs min.	100%
Electrical Test and Delta Parameter	—	Table 9	100%
Group A Test	—	Per data sheet and Table 8	100% Note.
Hermetic Fine Leak Gross Leak	1014	Condition A1 5×10^{-9} Pa m ³ /sec.Max. Condition C	100%
External Visual Inspection	2009		100%

Note) DC 100%, RF is Sampling Basis or 100%, depending on the parts.

Table 7 - 1 Absolute Maximum Ratings

Ta=25°C

Part No	Symbols	Parameters	Ratings	Units
UPC1677P(L) UPC1677B(L)	Vcc	Supply Voltage	6	V
	Icc	Supply Current	110	V
	PT	Total Power Dissipation	1.5	W
	PIN	Input Power	+10	mA
	Top	Operating Temperature	-55to+150	°C
	TSTG	Storage Temperature	-65to+200	°C
	Rth(j-c)		50	°C/W
UPC1678P(L) UPC1678B(L)	Vcc	Supply Voltage	6	V
	PIN	Input Power	+10	dBm
	PT	Total Power Dissipation	1.5	W
	Top	Operating Temperature	-55to+150	°C
	TSTG	Storage Temperature	-65to+200	°C
	Rth(j-c)		50	°C/W
UPC2708P(L) UPC2708B(L) UPC2711P(L) UPC2711B(L)	Vcc	Supply Voltage	6	V
	PIN	Input Power	+10	dBm
	PT	Power Dissipation	1.5	W
	Top	Operating Temperature	-55to+150	°C
	TSTG	Storage Temperature	-65to+200	°C
	Rth(j-c)		50	°C/W
UPC2709P(L) UPC2709B(L) UPC2712P(L) UPC2712B(L)	Vcc	Supply Voltage	6	V
	PIN	Input Power	+10	dBm
	PT	Power Dissipation	1.5	W
	Top	Operating Temperature	-55to+150	°C
	TSTG	Storage Temperature	-65to+200	°C
	Rth(j-c)		50	°C/W

Table 7 - 2 Absolute Maximum Rating

Ta=25°C

Part No	Symbols	Parameters	Ratings	Units
UPC2710P(L) UPC2710B(L) UPC2713P(L) UPC2713B(L)	Vcc	Supply Voltage	6	V
	PIN	Input Power	+10	dBm
	PT	Power Dissipation	1.5	W
	Top	Operating Temperature	-55to+150	°C
	TSTG	Storage Temperature	-65to+200	°C
	Rth(j-c)		50	°C/W
UPC2726P(L) UPC2726B(L)	Vcc	Supply Voltage	6	V
	PIN	Input Power	0	dBm
	PT	Power Dissipation	1.5	W
	Top	Operating Temperature	-40to+85	°C
	TSTG	Storage Temperature	-65to+200	°C
	Rth(j-c)		50	°C/W
UPB1508P(L) UPB1508B(L)	Vcc	Supply Voltage	-0.5to+6.0	V
	VIN	Input Voltage	-0.5to+6.0	V
	PIN	Input Power	+10	dBm
	PT	Power Dissipation	1.5	W
	Top	Operating Temperature	-55to+125	°C
	TSTG	Storage Temperature	-65to+200	°C
	Rth(j-c)		50	°C/W
UPB1509P(L) UPB1509B(L)	Vcc	Supply Voltage	-0.5to+6.0	V
	VIN	Input Voltage	-0.5to+6.0	V
	PIN	Input Power	+10	dBm
	PT	Power Dissipation	1.5	W
	Top	Operating Temperature	-55to+125	°C
	TSTG	Storage Temperature	-65to+200	°C
	Rth(j-c)		50	°C/W

Table 7 - 3 Absolute Maximum Rating

Ta=25°C

Part No	Symbols	Parameters	Ratings	Units
UPB1510P(L) UPB1510B(L)	Vcc	Supply Voltage	-0.5to+6.0	V
	VIN	Input Voltage	-0.5to+6.0	V
	PIN	Input Power	+10	dBm
	PT	Power Dissipation	1.5	W
	Top	Operating Temperature	-55to+125	°C
	TSTG	Storage Temperature	-65to+200	°C
	Rth(j-c)		50	°C/W
UPC2758P(L) UPC2758B(L) UPC8106P(L) UPC8106B(L)	Vcc.Vps	Supply Voltage	5.5	V
	PT	Power Dissipation	1.5	W
	Top	Operating Temperature	-55to+150	°C
	TSTG	Storage Temperature	-65to+200	°C
	Rth(j-c)		50	°C/W

Table 8 - 1 Electrical Characteristics : Group A

Ta=25°C

Part No	Parameter	Test Condition	Limits		Units
UPC1677P(L) UPC1677B(L)	I _{CC}	V _{CC} =5V	63	93	mA
	GS	V _{CC} =5V f=500MHz	22	—	dB
	P _{OUT}	V _{CC} =5V f=500MHz PIN=+3dBm	17.5	—	dBm
UPC1678P(L) UPC1678B(L)	I _{CC}	V _{CC} =5V	40	60	mA
	GS1	V _{CC} =5V f=500MHz	21	—	dB
	GS2	V _{CC} =5V f=1.7GHz	18	—	dB
	P _{OUT}	V _{CC} =5V f=500MHz PIN=+3dBm	15.5	—	dBm
UPC2708P(L) UPC2708B(L)	I _{CC}	V _{CC} =5V	20	33	mA
	GS1	V _{CC} =5V f=1GHz	13	—	dB
	GS2	V _{CC} =5V f=2.6GHz	10	—	dB
	P _{OUT}	V _{CC} =5V f=1GHz PIN=+0dBm	7.5	—	dBm
	NF	V _{CC} =5V f=1GHz	—	8	dB
UPC2709P(L) UPC2709B(L)	I _{CC}	V _{CC} =5V	19	32	mA
	GS1	V _{CC} =5V f=1GHz	21	—	dB
	GS2	V _{CC} =5V f=2GHz	18	—	dB
	P _{OUT}	V _{CC} =5V f=1GHz PIN=+0dBm	9	—	dBm
	NF	V _{CC} =5V f=1GHz	—	6.5	dB
UPC2710P(L) UPC2710B(L)	I _{CC}	V _{CC} =5V	16	29	mA
	GS1	V _{CC} =5V f=500MHz	30	—	dB
	GS2	V _{CC} =5V f=900MHz	27	—	dB
	P _{OUT}	V _{CC} =5V f=500MHz PIN=-10dBm	11	—	dBm
	NF	V _{CC} =5V f=500MHz	—	5	dB

Table 8 - 2 Electrical Characteristics : Group A

Ta=25°C

Part No	Parameter	Test Condition	Limits		Units
UPC2711P(L) UPC2711B(L)	I _{CC}	V _{CC} =5V	9	15	mA
	GS1	V _{CC} =5V f=1GHz	11	—	dB
	GS2	V _{CC} =5V f=2.5GHz	8	—	dB
	P _{OUT}	V _{CC} =5V f=1GHz PIN=-5dBm	-3	—	dBm
	NF	V _{CC} =5V f=1GHz	—	6.5	dB
UPC2712P(L) UPC2712B(L)	I _{CC}	V _{CC} =5V	9	15	mA
	GS1	V _{CC} =5V f=1GHz	18	—	dB
	GS2	V _{CC} =5V f=2.2GHz	15	—	dB
	P _{OUT}	V _{CC} =5V f=1GHz PIN=-10dBm	0	—	dBm
	NF	V _{CC} =5V f=1GHz	—	6	dB
UPC2713P(L) UPC2713B(L)	I _{CC}	V _{CC} =5V	9	15	mA
	GS1	V _{CC} =5V f=500MHz	26	33	dB
	GS2	V _{CC} =5V f=0.9GHz	23	—	dB
	P _{OUT}	V _{CC} =5V f=500MHz PIN=+0dBm	4	—	dBm
	NF	V _{CC} =5V f=500MHz	—	4.5	dB
UPC2726P(L) UPC2726B(L)	I _{CC}	V _{CC} =5V	8	15	mA
	GP1	V _{CC} =5V f=400MHz	11	17	dB
	GP2	V _{CC} =5V f=1000MHz	8	—	dB
	P _{o(SAT)1}	V _{CC} =5V f=400MHz PIN=-10dBm	-5	—	dBm
	P _{o(SAT)2}	V _{CC} =5.2V f=400MHz PIN=-3dBm	-2	—	dBm
	NF	V _{CC} =5V f=400MHz	—	6	dB

Table 8 - 3 Electrical Characteristics : Group A

Ta=25°C

Part No	Parameter	Test Condition	Limits		Units
UPB1508P(L) UPB1508B(L)	I _{CC}	V _{CC} =5V	7.0	14.5	mA
	f _{IN1}	PIN=-15~+5dBm	0.5	2.7	GHz
	f _{IN2}	PIN=-10~+5dBm	0.5	3.0	GHz
	P _{OUT}	V _{CC} =5V f _{IN} =2GHz PIN=0dBm	-12	—	dBm
UPB1509P(L) UPB1509B(L)	I _{CC}	V _{CC} =3V	2.5	5.9	mA
	f _{IN1}	PIN=-20~+0dBm, ×1/2	50	500	MHz
	f _{IN2}	PIN=-20~+0dBm, ×1/8	50	500	MHz
	f _{IN3}	PIN=-20~-5dBm, ×1/2	50	700	MHz
	f _{IN4}	PIN=-20~-5dBm, ×1/8	50	1000	MHz
UPB1510P(L) UPB1510B(L)	I _{CC}	V _{CC} =5V	9.0	19.0	mA
	f _{IN1}	PIN=-15~+5dBm	0.5	2.7	GHz
	f _{IN2}	PIN=-10~+5dBm	0.5	3.0	GHz
	P _{OUT}	V _{CC} =5V f _{IN} =2GHz PIN=0dBm	-12	—	dBm
UPC2758P(L) UPC2758B(L)	I _{CC}	V _{CC} =3V	6.6	14.8	mA
	CG1	f _{RF} =2GHz f _{IF} =250MHz PRF=-40dBm	14	20	dB
	CG2	f _{RF} =800MHz f _{IF} =130MHz PRF=-40dBm	16	22	dB
	P _{OUT1}	f _{RF} =2GHz f _{IF} =250MHz PRF=-10dBm	-7	—	dBm
	P _{OUT2}	f _{RF} =800MHz f _{IF} =130MHz PRF=-10dBm	-7	—	dBm
UPC8106P(L) UPC8106B(L)	I _{CC}	V _{CC} =3V	4.5	13.5	mA
	CG	f _{RF} =1.9GHz P _{IF} =-30dBm f _{IF} =240MHz	4	—	dB
	P _{OUT}	f _{RF} =1.9GHz P _{IF} =-10dBm f _{IF} =240MHz	-8	—	dBm

Table 9 Delta Parameters and Criteria for Silicon MMICs

Delta Parameter	Symbol	Maximum Allowable Delta for Power Burn-in
		Grade L Si MMIC
Circuit Current	I _{cc}	±10%

5. PACKAGE (Dimensions, Marking, LEAD Connections)

5-1. PACKAGE FOR BIPOLAR TRANSISTOR

(LEAD MATERIAL : KOVAR, LEAD FINISH : Ni/Au plated) (Units in mm)

1) NE02103(L)

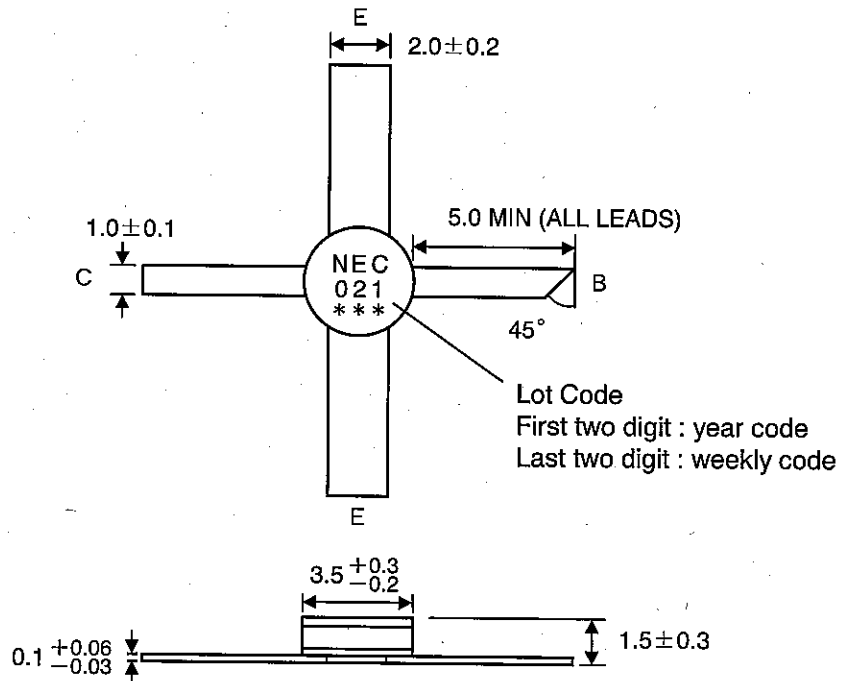

2) NE02107(L)

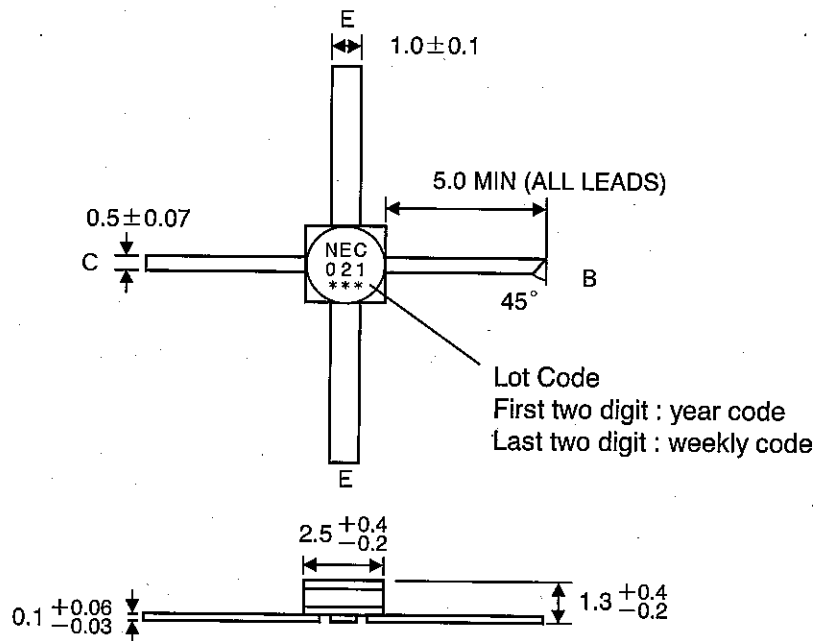

3) NE02108(L)

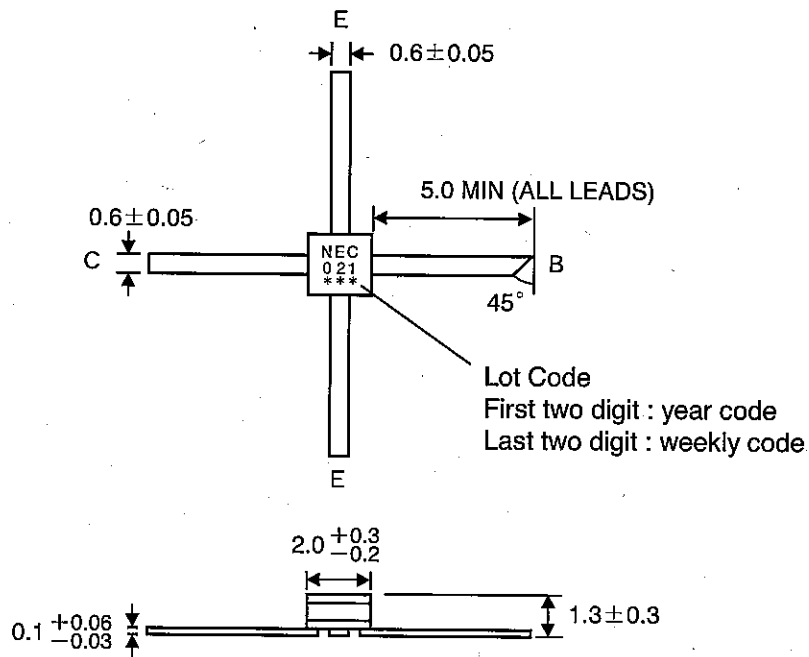

4) NE41603(L)

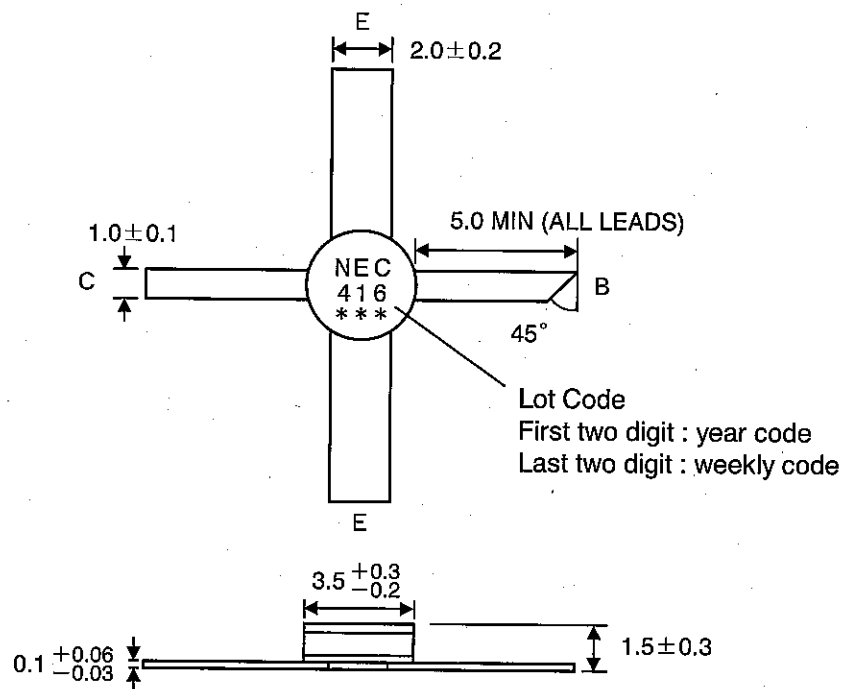

5) NE41607(L)

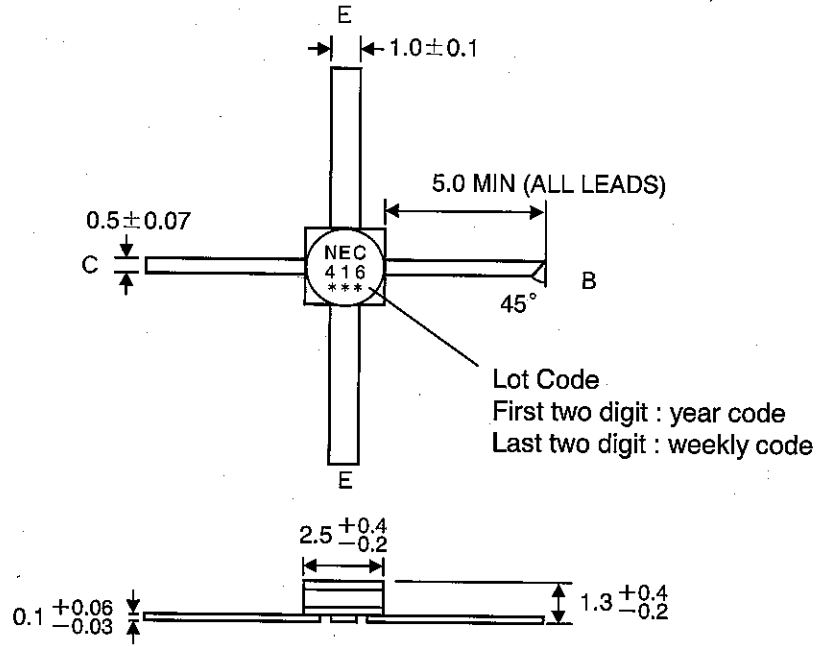

6) NE68008(L)

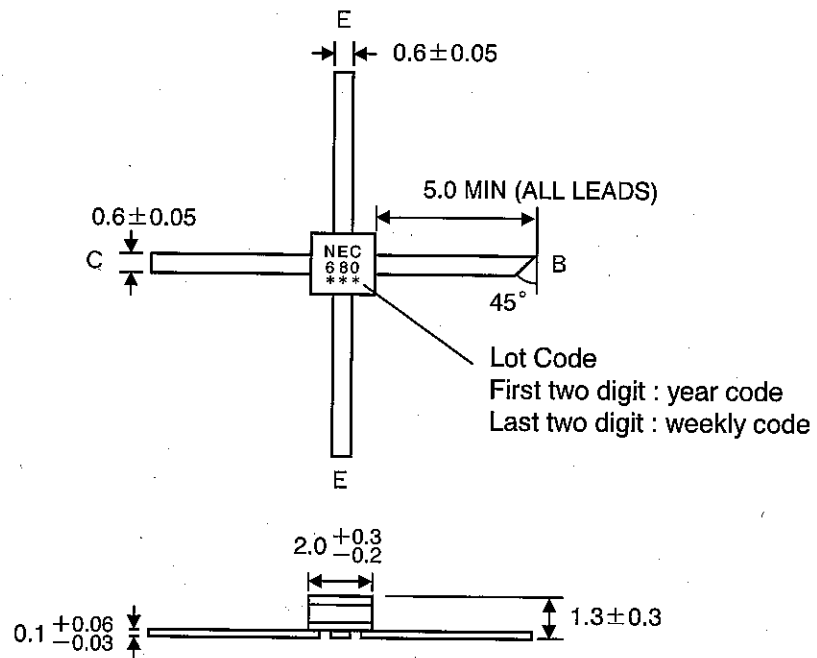

7) NE68108(L)

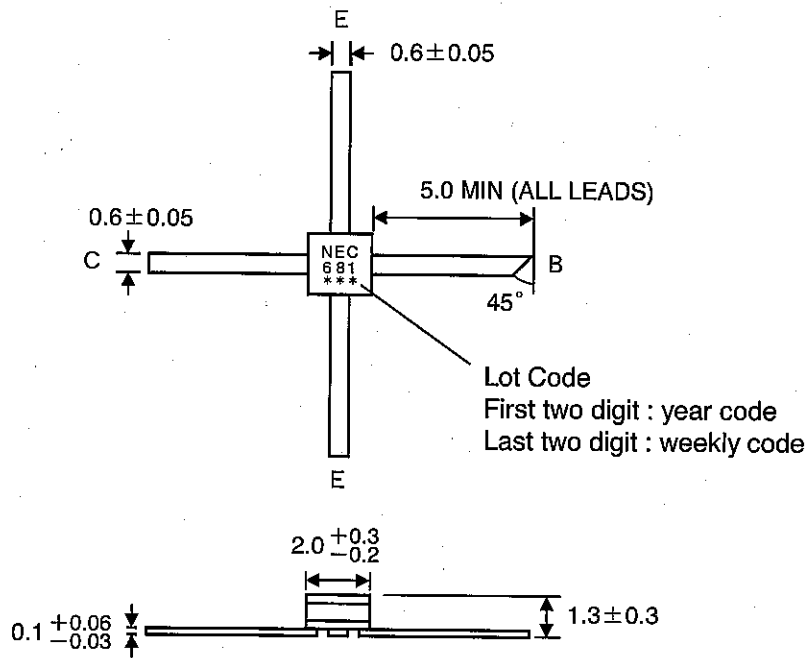

8) NE73408(L)

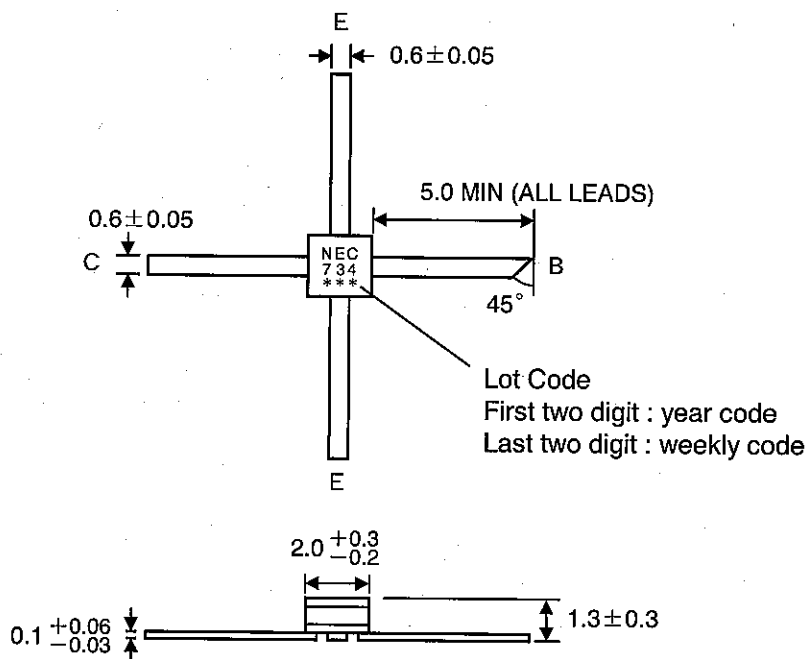

9) NE85608(L)

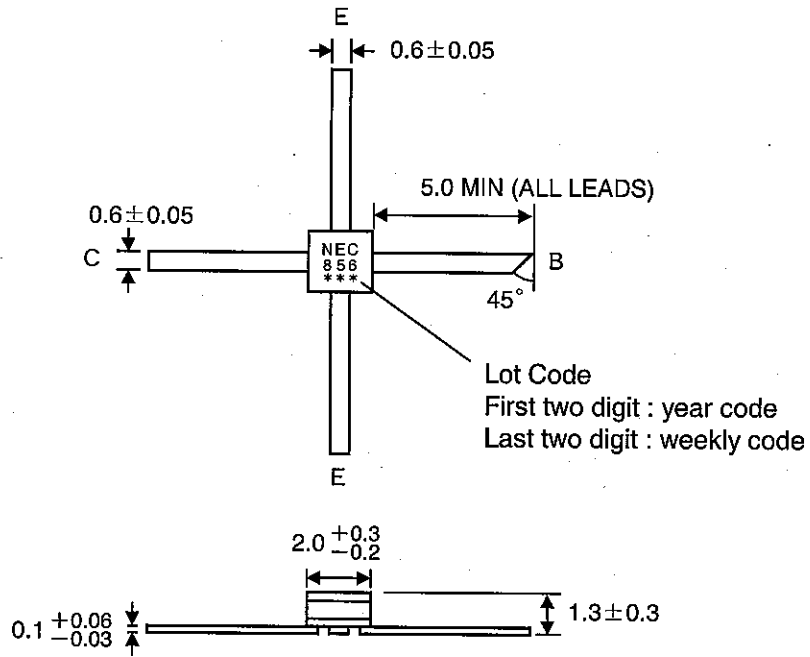

10) NE89407(L)

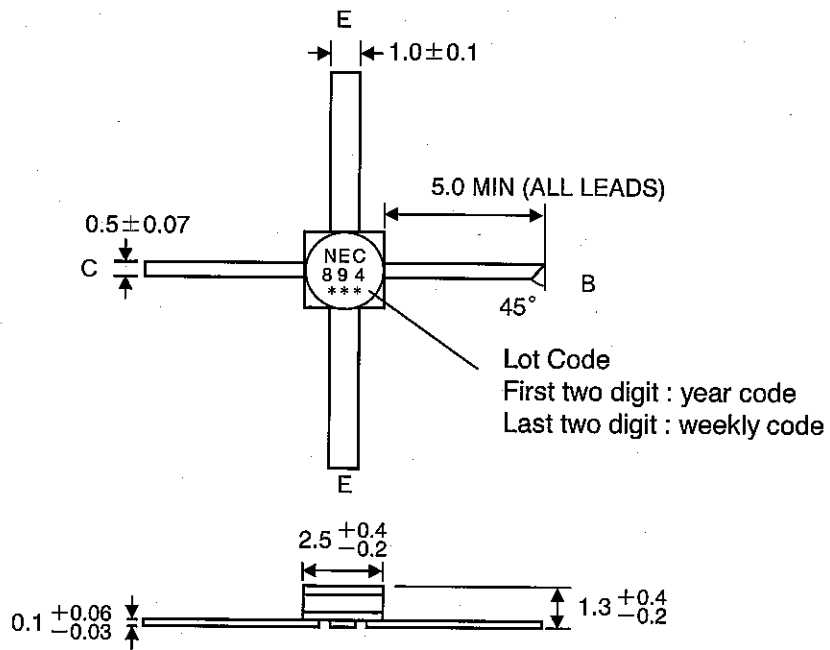

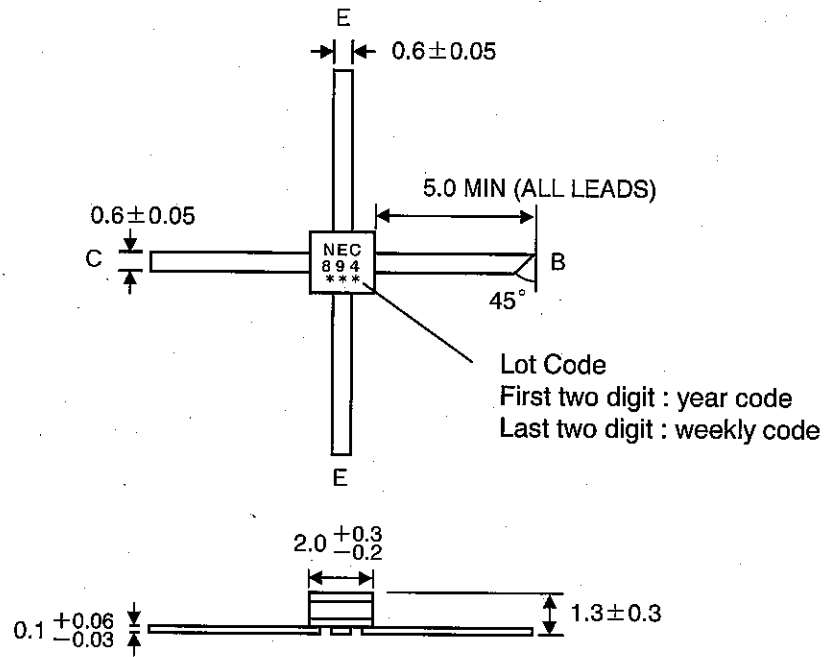

5-2 PACKAGE FOR SiMMIC

(LEAD MATERIAL : LEAD, FINISH : See the note of this para 5-2)

(Units in mm)

1) UPC1677B(L) , 1678B(L)

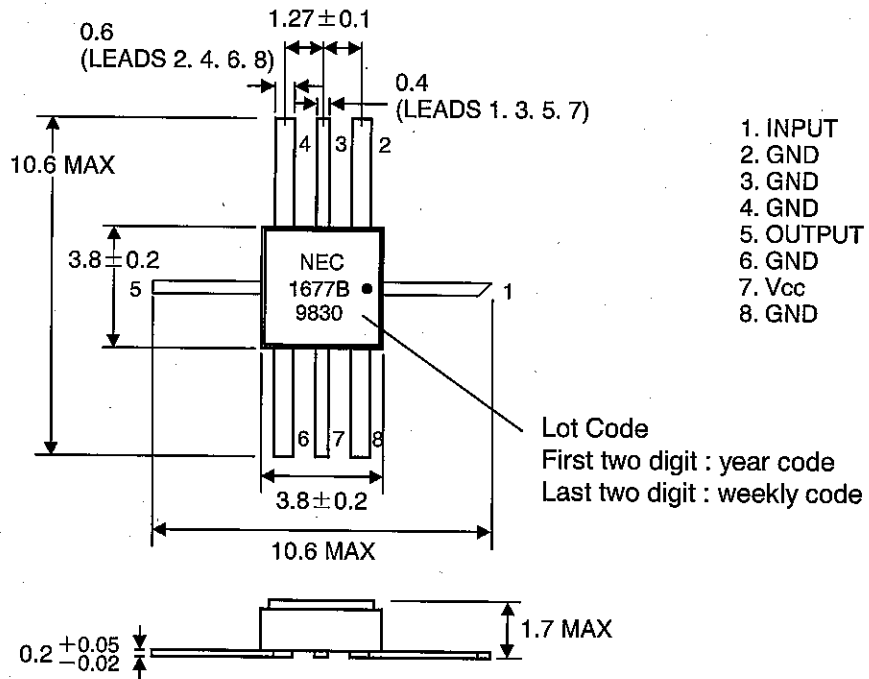

2) UPC2708B(L) , 2709B(L) , 2710B(L) , 2711B(L) , 2712B(L) , 2713B(L)

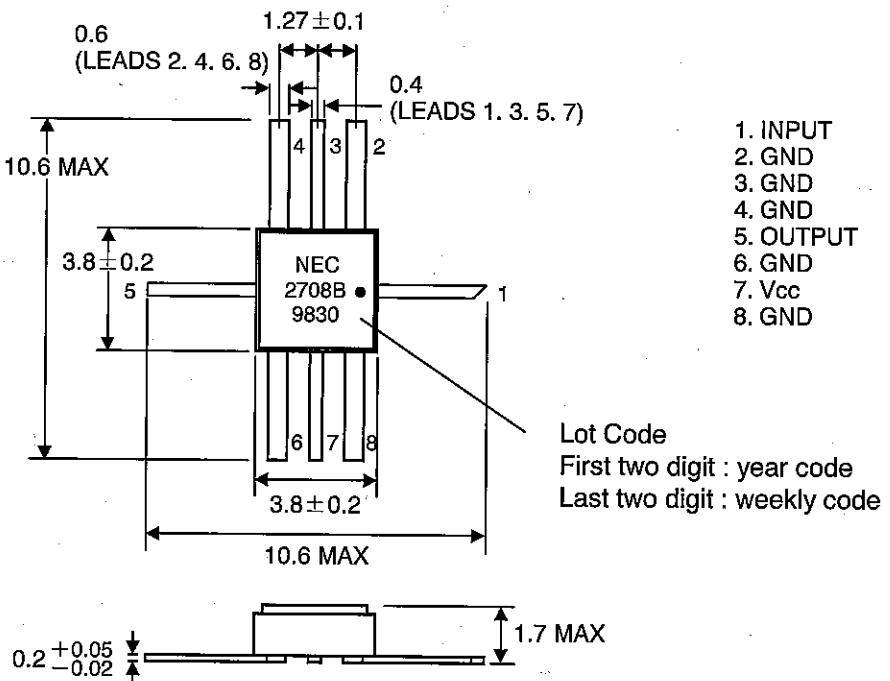

3) UPC2758B(L) , UPC8106B(L)

(Units in mm)

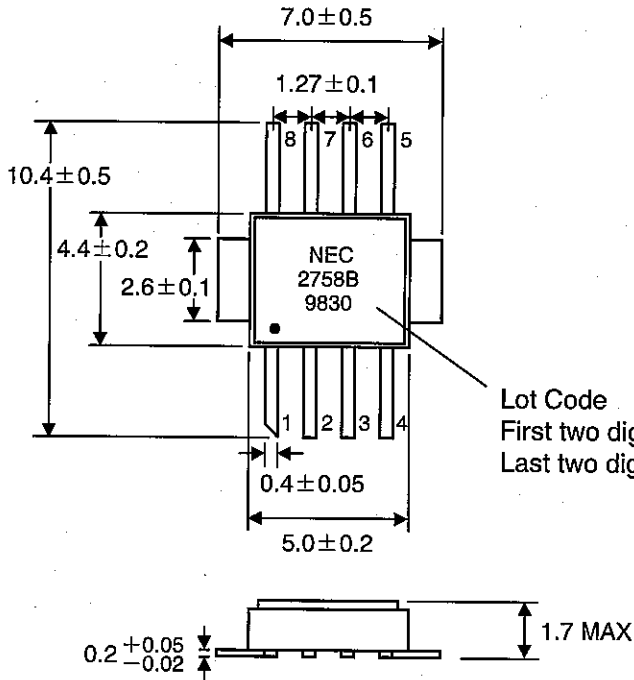

UPC2758B(B)	UPC8106B(B)
1. IF OUTPUT	1. RF INPUT
2. GND	2. GND
3. RF IN PUT	3. IF INPUT
4. NC	4. NC
5. NC	5. NC
6. LO INPUT	6. LO INPUT
7. PS	7. PS
8. Vcc	8. Vcc

Lot Code
 First two digit : year code
 Last two digit : weekly code

4) UPB1508B(L) , 1509B(L) , 1510B(L) , UPC2726B(L)

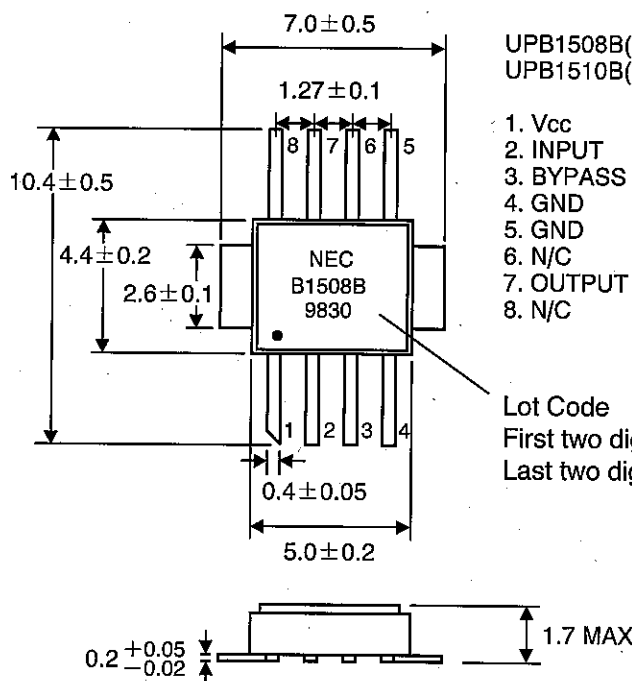

UPB1508B(B) UPB1510B(B)	UPB1509B(L)	UPC2726B(L)
1. Vcc	1. Vcc 1	1. $\overline{\text{OUT}}$
2. INPUT	2. INPUT	2. Vcc
3. BYPASS	3. BYPASS	3. NC
4. GND	4. GND	4. IN
5. GND	5. M1	5. $\overline{\text{IN}}$
6. N/C	6. M2	6. NC
7. OUTPUT	7. OUTPUT	7. NC
8. N/C	8. Vcc 2	8. OUT
		GND: Backside Metal

Lot Code
 First two digit : year code
 Last two digit : weekly code

Note :

LEAD MATERIAL	LEAD FINISH	PART NUMBER	
Copper Clad iron	Ni/Au Plated	UPC1677B(L) UPC1678B(L) UPC2708B(L) UPC2709B(L)	UPC2710B(L) UPC2711B(L) UPC2712B(L) UPC2713B(L)
Copper Clad KOVAR	Ni/Au Plated	UPB1508B(L) UPB1509B(L) UPB1510B(L) UPC2726B(L)	UPC8106B(L) UPC2758B(L)

6. CHIP Design (Pad Connections, Chip Drawings)

6-1. Chip for Bipolar Transistor

1) NE02100(L)

①Metallization

- Emitter and Base Metal : Au
- Bonding Pad Metal : Au
- Backside Metal : Au

②Chip Configuration

- Chip Thickness : $160 \pm 20 \mu\text{m}$
- Chip Size : $0.35 \times 0.35\text{mm}$
- Passivation Film : SiO_2

③Chip Drawing (Units in mm)

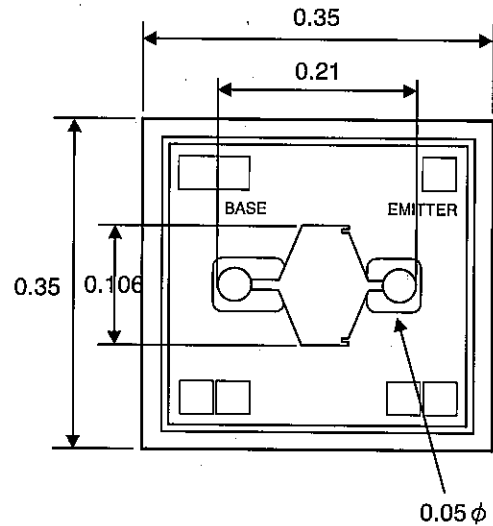

2) NE41600(L)

①Metallization

- Emitter and Base Metal : Au
- Bonding Pad Metal : Au
- Backside Metal : Au

②Chip Configuration

- Chip Thickness : $160 \pm 20 \mu\text{m}$
- Chip Size : $0.40 \times 0.40\text{mm}$
- Passivation Film : SiO_2

③Chip Drawing (Units in mm)

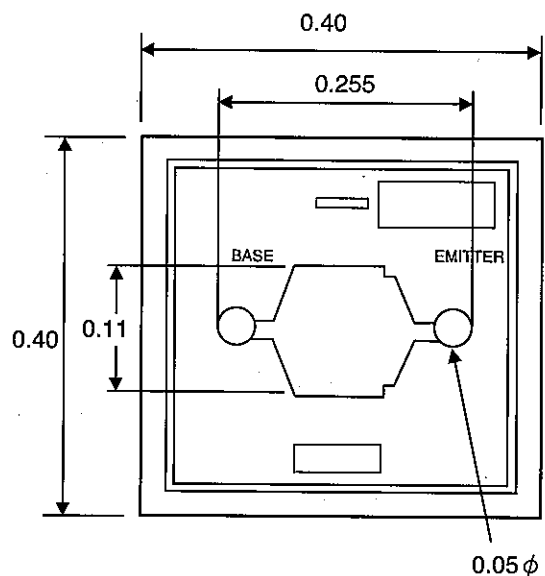

3) NE68000(L)

① Metallization

- Emitter and Base Metal : Au
- Bonding Pad Metal : Au
- Backside Metal : Au

② Chip Configuration

- Chip Thickness : $160 \pm 20 \mu\text{m}$
- Chip Size : $0.35 \times 0.35\text{mm}$
- Passivation Film : SiN

③ Chip Drawing (Units in mm)

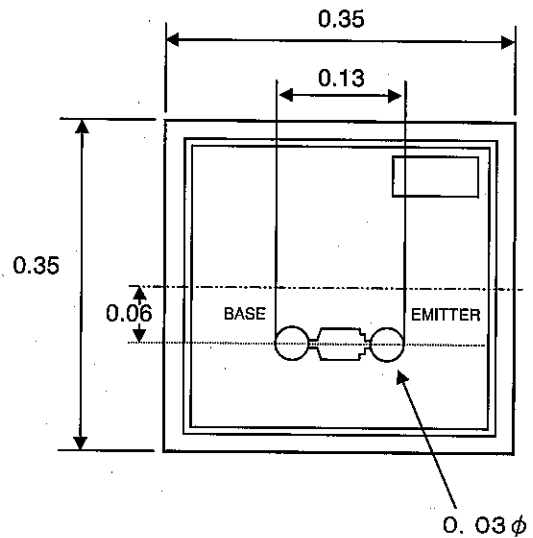

4) NE68100(L)

① Metallization

- Emitter and Base Metal : Au
- Bonding Pad Metal : Au
- Backside Metal : Au

② Chip Configuration

- Chip Thickness : $160 \pm 20 \mu\text{m}$
- Chip Size : $0.35 \times 0.35\text{mm}$
- Passivation Film : SiN

③ Chip Drawing (Units in mm)

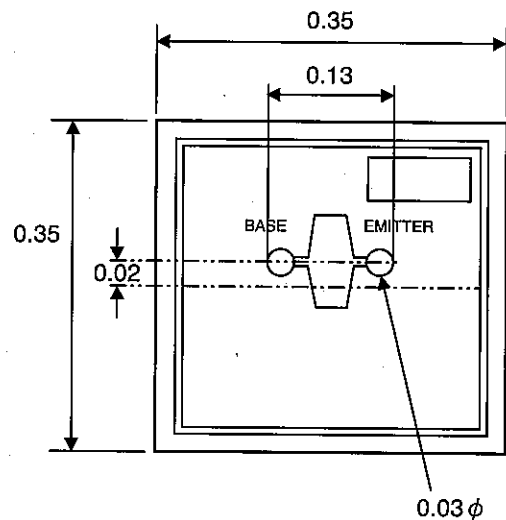

5) NE73400(L)

①Metallization

- Emitter and Base Metal : Au
- Bonding Pad Metal : Au
- Backside Metal : Au

②Chip Configuration

- Chip Thickness : $160 \pm 20 \mu\text{m}$
- Chip Size : $0.35 \times 0.35\text{mm}$
- Passivation Film : SiO_2

③Chip Drawing (Units in mm)

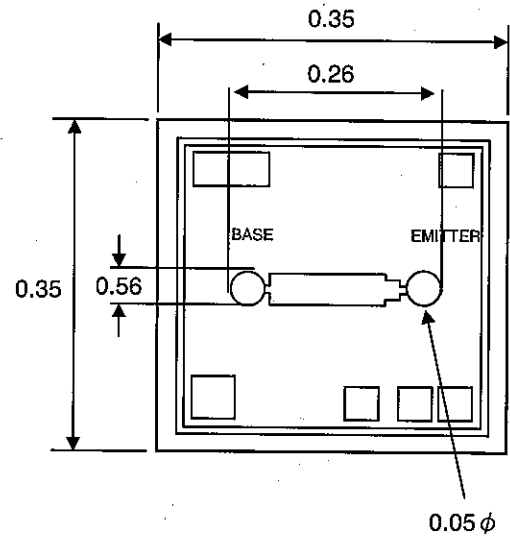

6) NE85600(L)

①Metallization

- Emitter and Base Metal : Au
- Bonding Pad Metal : Au
- Backside Metal : Au

②Chip Configuration

- Chip Thickness : $160 \pm 20 \mu\text{m}$
- Chip Size : $0.35 \times 0.35\text{mm}$
- Passivation Film : SiN

③Chip Drawing (Units in mm)

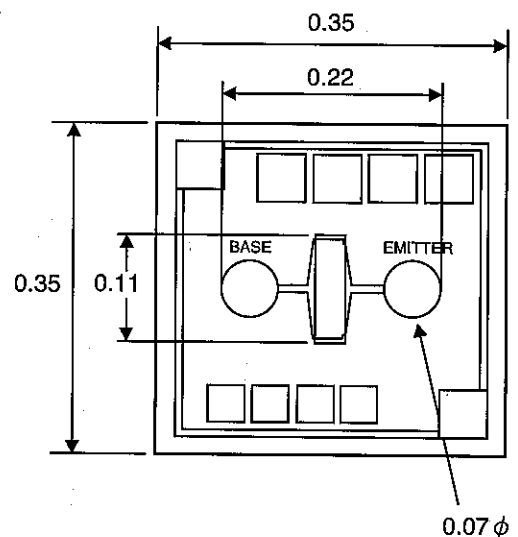

7) NE89400(L)

①Metallization

- Emitter and Base Metal : Au
- Bonding Pad Metal : Au
- Backside Metal : Au

②Chip Configuration

- Chip Thickness : $160 \pm 20 \mu\text{m}$
- Chip Size : $0.29 \times 0.29\text{mm}$
- Passivation Film : SiN

③Chip Drawing (Units in mm)

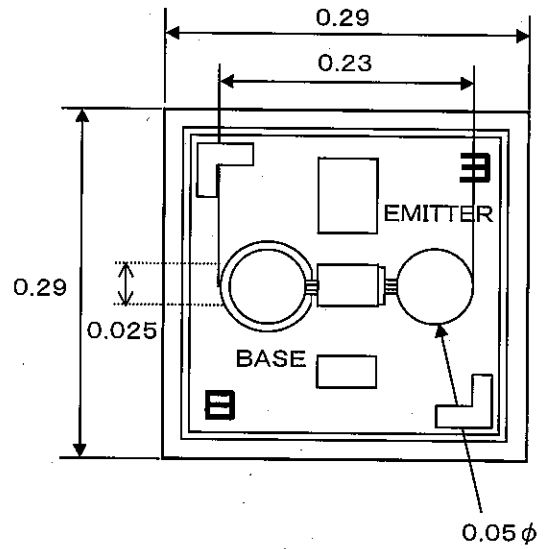

6. CHIP Design (Pad Connections, Chip Drawings)

6-2. Chip for Si MMIC

1) UPC1677P(L), 1678P(L)

①Metallization

- Emitter and Base Metal : Au
- Bonding Pad Metal : Au
- Backside Metal : Au

②Chip Configuration

- Chip Thickness : $200 \pm 20 \mu\text{m}$
- Chip Size : $0.83 \times 0.83\text{mm}$
- Bonding Pad Size : $100 \times 100 \mu\text{m}$
- Passivation Film : SiN

③Chip Drawing (Units in mm)

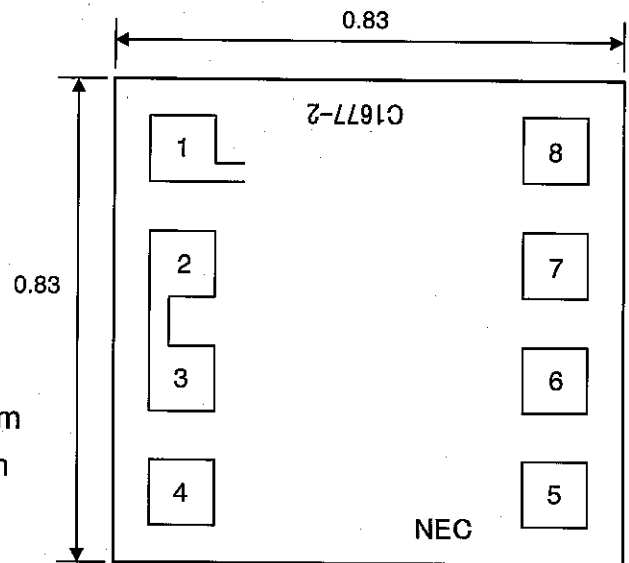

PAD CONNECTIONS

- | | |
|----------|-----------|
| 1. INPUT | 5. OUTPUT |
| 2. GND | 6. GND |
| 3. GND | 7. GND |
| 4. GND | 8. Vcc |

2) UPC2708P(L), 2709P(L), 2710P(L) 2711P(L), 2712P(L), 2713P(L)

①Metallization

- Emitter and Base Metal : Au
- Bonding Pad Metal : Au
- Backside Metal : Au

②Chip Configuration

- Chip Thickness : $200 \pm 20 \mu\text{m}$
- Chip Size : $0.66 \times 0.69\text{mm}$
- Bonding Pad Size : $100 \times 100 \mu\text{m}$
- Passivation Film : SiN

③Chip Drawing (Units in mm)

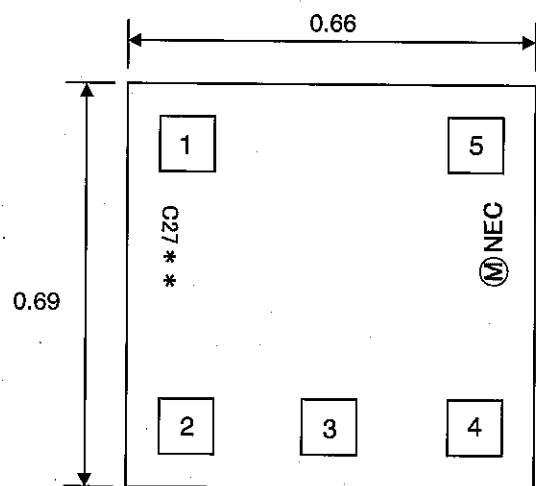

PAD CONNECTIONS

- | | |
|----------|-----------|
| 1. INPUT | 4. OUTPUT |
| 2. GND | 5. Vcc |
| 3. GND | |

3) UPC2726P(L)

①Metallization

- Emitter and Base Metal : Au
- Bonding Pad Metal : Au
- Backside Metal : Au

②Chip Configuration

- Chip Thickness : $200 \pm 20 \mu\text{m}$
- Chip Size : $0.66 \times 0.66\text{mm}$
- Bonding Pad Size : $100 \times 100 \mu\text{m}$
- Passivation Film : SiN

③Chip Drawing (Units in mm)

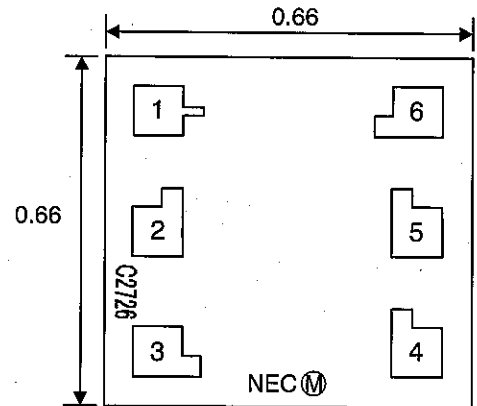

PAD CONNECTIONS

- | | |
|--------|--------|
| 1. IN | 4. OUT |
| 2. GND | 5. OUT |
| 3. IN | 6. Vcc |

4) UPC2758P(L)

①Metallization

- Emitter and Base Metal : Au
- Bonding Pad Metal : Au
- Backside Metal : Au

②Chip Configuration

- Chip Thickness : $200 \pm 20 \mu\text{m}$
- Chip Size : $0.66 \times 0.66\text{mm}$
- Bonding Pad Size : $100 \times 100 \mu\text{m}$
- Passivation Film : SiN

③Chip Drawing (Units in mm)

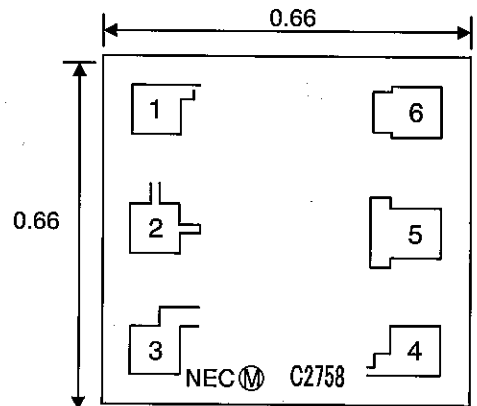

PAD CONNECTIONS

- | | |
|--------------|-------------|
| 1. IF OUTPUT | 4. LO INPUT |
| 2. GND | 5. PS |
| 3. RF INPUT | 6. Vcc |

5) UPC8106P(L)

①Metallization

- Emitter and Base Metal : Au
- Bonding Pad Metal : Au
- Backside Metal : Au

②Chip Configuration

- Chip Thickness : $200 \pm 20 \mu\text{m}$
- Chip Size : $0.66 \times 0.66\text{mm}$
- Bonding Pad Size : $100 \times 100 \mu\text{m}$
- Passivation Film : SiN

③Chip Drawing (Units in mm)

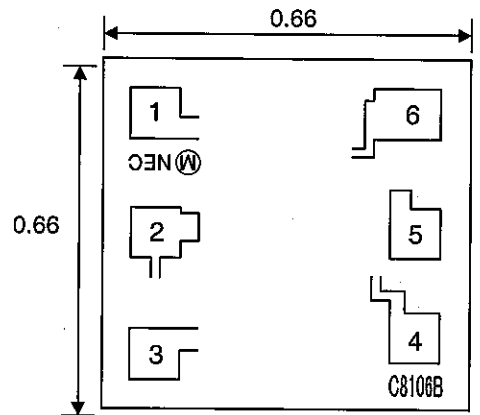

PAD CONNECTIONS

- | | |
|--------------|-------------|
| 1. RF OUTPUT | 4. LO INPUT |
| 2. GND | 5. PS |
| 3. IF INPUT | 6. Vcc |

5) UPB1508P(L), 1510P(L)

① Metallization

- Emitter and Base Metal : Au
- Bonding Pad Metal : Au
- Backside Metal : Au

② Chip Configuration

- Chip Thickness : $200 \pm 20 \mu\text{m}$
- Chip Size : $0.8 \times 0.8\text{mm}$
- Bonding Pad Size : $100 \times 100 \mu\text{m}$
- Passivation Film : SiN

③ Chip Drawing (Units in mm)

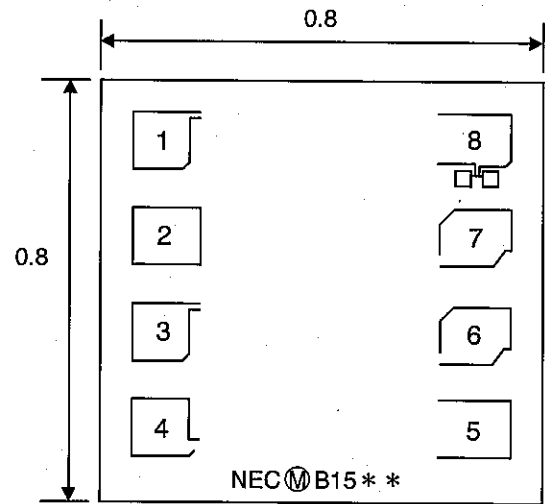

PAD CONNECTIONS

- | | |
|--------|--------|
| 1. GND | 5. Vcc |
| 2. N/D | 6. IN |
| 3. OUT | 7. INb |
| 4. N/D | 8. GND |

6) UPB1509P(L)

① Metallization

- Emitter and Base Metal : Au
- Bonding Pad Metal : Au
- Backside Metal : Au

② Chip Configuration

- Chip Thickness : $200 \pm 20 \mu\text{m}$
- Chip Size : $0.8 \times 0.8\text{mm}$
- Bonding Pad Size : $100 \times 100 \mu\text{m}$
- Passivation Film : SiN

③ Chip Drawing (Units in mm)

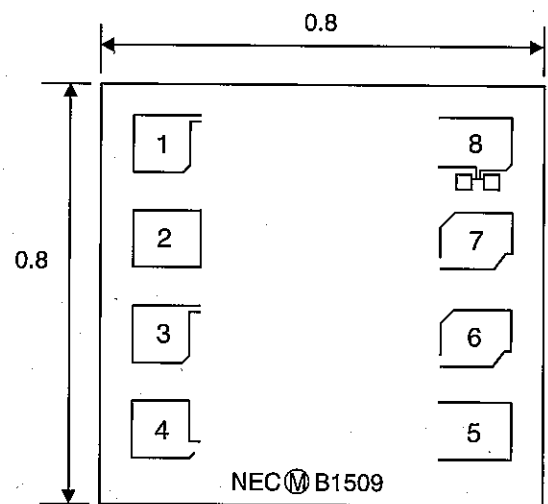

PAD CONNECTIONS

- | | |
|---------|---------|
| 1. M1 | 5. Vcc1 |
| 2. M2 | 6. IN |
| 3. OUT | 7. INb |
| 4. Vcc2 | 8. GND |

Revision Change Record		(Appendix 1/1)		
Revision	Description	Date	Prepared	Approved
A	Original Issue	April 1, '98 April 1, '98	A.Horita T.Wako K.Yamanaka	M.Itoh M.Matsuo
B	Added NE680##(L) in Table I ,III and IV	Dec.18, '98	A.Horita T.Wako K.Yamanaka	M.Ishino M.Matsuo
C	Added UPB15##(L) in Table I ,VII and VIII	March.5, '98	A.Horita T.Wako K.Yamanaka	M.Ishino M.Matsuo
D	Revised for Lead Material of SiMMIC Added note "discon" for prescaler	September. 2, '99	T.Wako K.Yamanaka	M. Matsuo M. Ishino
E	<ul style="list-style-type: none"> · Added UPC2726B(L) in Table I , VII and VIII · Reviewed Rth in Table3-1 · Page 5/37, MIL-STD-883 Method 2010 of 100% INTERNAL VISUAL INSPECTION is changed to MIL-STD-750 Method 2072 · The same note as table 2 is added in Table6 	March. 5, '02	T.Wako Y.Sato	K.Itoh T.Yokokawa
F	<ul style="list-style-type: none"> · Added New Release NE89400(L) ,07(L) and,08(L) in Table I ,III and IV. · Added the parts to phased out to Table1. · Deleted UPB584B(L),585B(L) and 587B(L) · Added note "phased out for Tr. and Amp. · Page 7/37: Added "NEC Specification" for applicable Internal Visual Inspection specification · Deleted "10Cycles Grade D" for Temp. Cycling Condition. · Changed to 5×10^{-9} Pam³/sec.Max. for SI unit Fine Leak criteria · Page15/37 :added "2Hr Ta=200°C" for Pre Cap Bake Condition · Changed to 5×10^{-9} Pam³/sec.Max. for SI unit Fine Leak criteria · Page31/37 :Chip Thickness for NE02100 (L) changed to $160 \pm 20\mu\text{m}$ · Page35/37 :Chip Thickness for UPC1677P (L), 1678P(L) changed to $200 \pm 20\mu\text{m}$ 	December. 16 '02.	A. Horita T. Wako Y. Sato	K. Itoh T. Yokokawa