

Infrared Emitting Diode

KEL-5315C

Description

The KEL-5315C is a ultra bright light & surface mount type infrared emitting diode. It's ideal for various kinds of optical emitters such as touch panels for C/D, ATM, Car navigation system and even AV Instrument and various types of disk driver.

Features

- Compact and thin package
- SMD type
- Reflow soldering
- RoHS & High reliability package

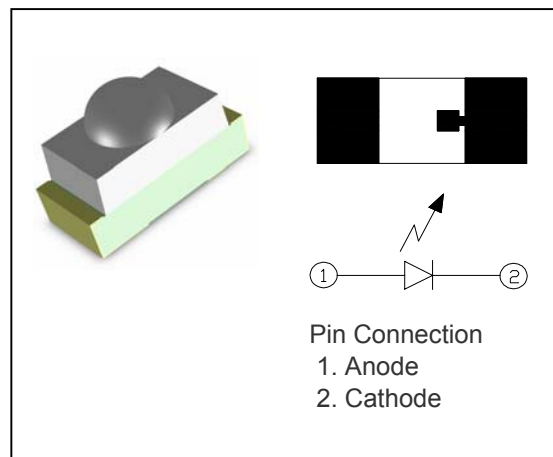

Pin Connection
1. Anode
2. Cathode



Applications

- Touch screen for ATM
- Touch screen for Car navigation system
- Touch screen for FA equipment
- AV instrument
- Various types of disk driver

Absolute Maximum Ratings

[T_A = 25°C]

Parameter	Symbol	Min.	Max.	Max.
Reverse Voltage	V _R	-	6	V
Forward Current	I _F	-	50	mA
Power Dissipation	P _D	-	75	mW
Pulse Forward Current*1	I _{FP}	-	0.5	A
Operating Temperature	T _{opr}	-20	85	°C
Storage Temperature	T _{stg}	-30	85	°C
Soldering Temperature*2	T _{sol}	-	260	°C

*1 : Pulse Width : T_w ≤ 100μs, Periode : T = 10ms

*2 : MAX 10s

The contents of this data sheet are subject to change without advance notice for the purpose of improvement.
When using this product, would you please refer to the latest specifications.

KEL-5315C

Electrical Characteristics

[T_A = 25°C]

Parameter	Symbol	Conditions	Min.	Typ.	Max.	Unit
Forward Voltage	V _F	I _F =20mA	-	1.2	1.4	V
Reverse Current	I _R	V _R =5V	-	-	10	μA
Radiant Intensity	P _O	I _F =20mA	2.0	2.5	-	mW/sr
Peak Emission Wavelength	λ _p	I _F =20mA	-	940	-	nm
Spectral Bandwidth 50%	Δλ	I _F =20mA	-	45	-	nm
Half Angle	Δθ	-	-	±15	-	deg

Ordering Information

Part Number	Packaging Type	Quantity
KEL-5315C	Tape and Reel	4,000

Package Outline Dimensions

(Unit : mm)

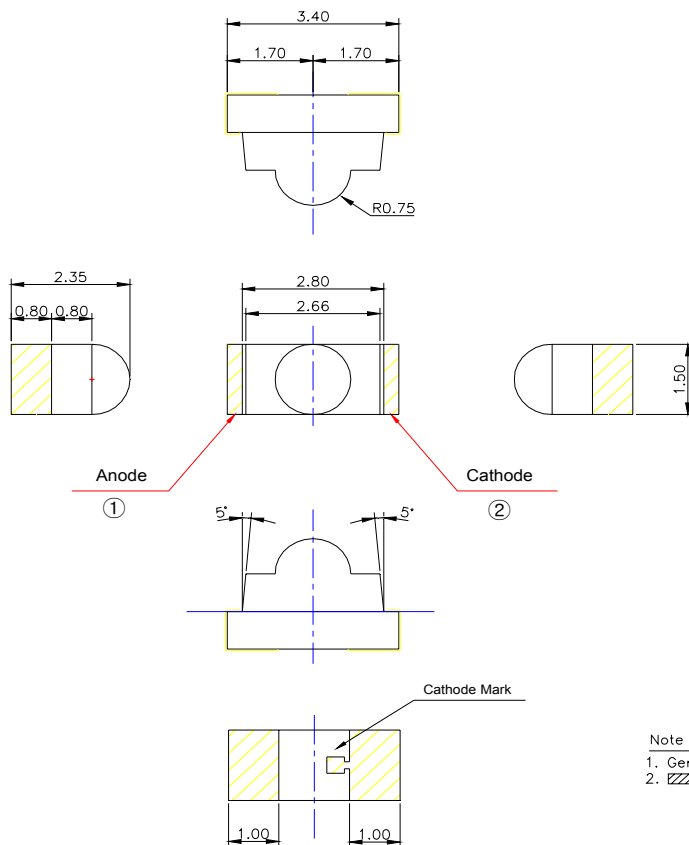

- Note
1. General tolerance : ±0.2mm
 2. Au plate

The contents of this data sheet are subject to change without advance notice for the purpose of improvement.
When using this product, would you please refer to the latest specifications.