

280-006 MIL-DTL-24308/9 Hermetic Glass-Sealed D-Subminiature Receptacle

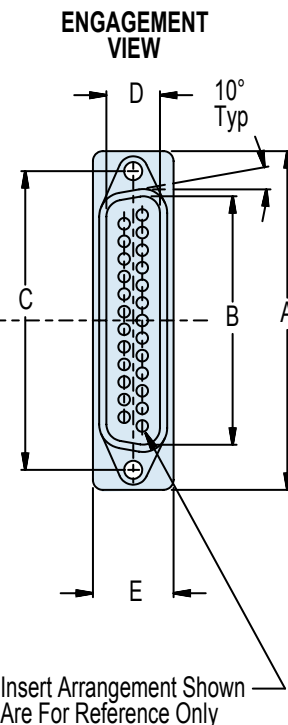

SOLDER CUP ORIENTATION

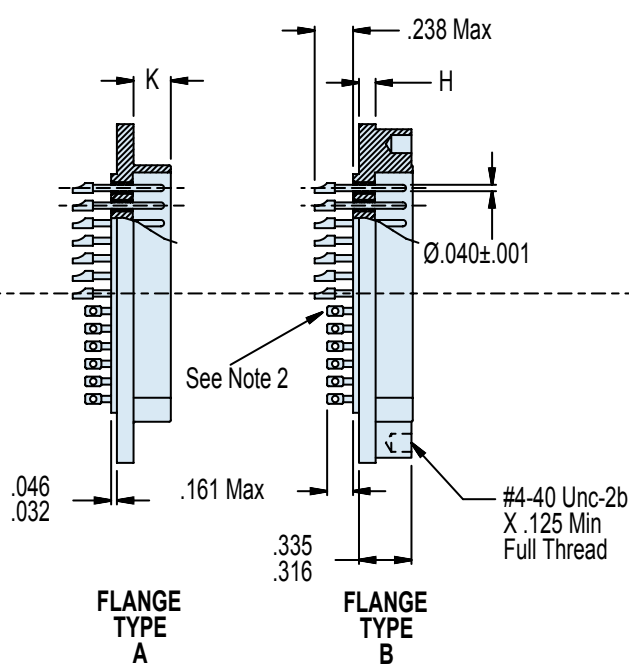
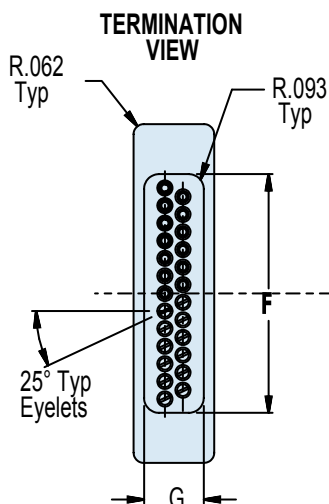
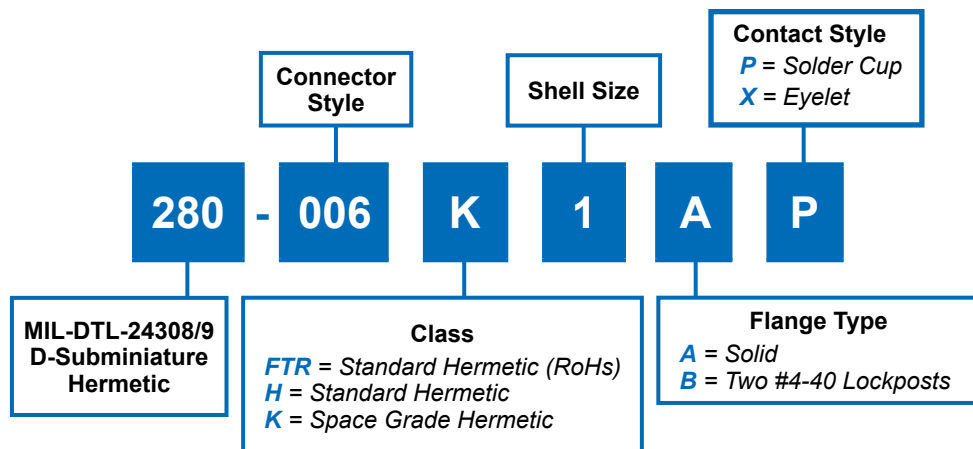
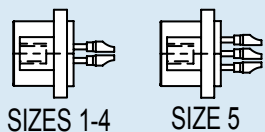

APPLICATION NOTES

- To be identified with manufacturer's name, part number and date code, space permitting.
- Contact Style: Eyelet or Solder Cup (See Part Number Development).
- Material/Finish:
Shell: H = FT - Carbon steel/tin plate.
K = Z16 = Stainless steel/nickel plated, dull finish.
FTR = Carbon steel/tin fused (RoHs compliant)
Insulators: Glass bead/N.A.
Contacts: Pins, Alloy 52/gold plated
- Performance:
DWV - 750 VAC Pin-to-Shell
I.R. - 5,000 MegOhms Min @ 500 VDC
Hermeticity 1×10^{-7} cc He/sec @ 1 atmosphere differential
- Glenair 280-006 will mate with any QPL MIL-DTL-24308/1, /2 and /23 receptacle of the same size and arrangement.
- All dimensions are typical for flange types "A" and "B". "C" dim is not applicable to flange type "A".
- Metric dimensions (mm) are indicated in parentheses.

Dimensions in Inches (millimeters) are subject to change without notice.

280-006
MIL-DTL-24308/9 Hermetic
Glass-Sealed D-Subminiature Receptacle



MIL-DTL-24308

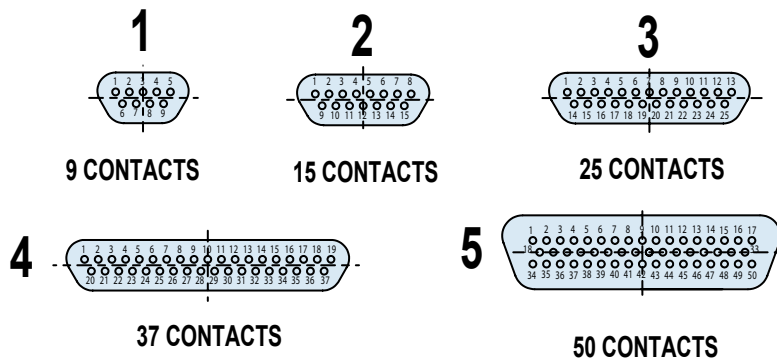

HERMETIC LEAK RATE MOD CODES	
Designator	Required Leak Rate
-585A	1 x 10 ⁻¹⁰ cc Helium per second
-585B	1 x 10 ⁻⁹ cc Helium per second
-585C	1 x 10 ⁻⁸ cc Helium per second

TABLE I: CONNECTOR DIMENSIONS									
Shell Size	Dim A ± .015 (± 0.4)	Dim B ± .004 (± 0.1)	Dim C ± .005 (± 0.1)	Dim D ± .004 (± 0.1)	Dim E ± .010 (± 0.3)	Dim F ± .010 (± 0.3)	Dim G ± .010 (± 0.3)	Dim H ± .006 (± 0.2)	Dim K ± .010 (± 0.3)
1	1.213 (30.8)	.667 (16.9)	.984 (25.0)	.330 (8.4)	.498 (12.6)	.725 (18.4)	.369 (9.4)	.094 (2.4)	.235 (6.0)
2	1.541 (39.1)	.993 (25.2)	1.312 (33.3)	.330 (8.4)	.498 (12.6)	.932 (23.7)	.369 (9.4)	.094 (2.4)	.235 (6.0)
3	2.088 (53.1)	1.535 (39.0)	1.852 (47.0)	.330 (8.4)	.498 (12.6)	1.479 (37.6)	.369 (9.4)	.103 (2.6)	.230 (5.8)
4	2.729 (69.3)	2.183 (55.4)	2.500 (63.5)	.330 (8.4)	.498 (12.6)	2.125 (54.0)	.369 (9.4)	.103 (2.6)	.230 (5.8)
5	2.635 (66.0)	2.079 (52.8)	2.406 (61.1)	.441 (11.2)	.610 (15.5)	2.000 (50.8)	.500 (12.7)	.103 (2.6)	.230 (5.8)

RECOMMENDED PANEL CUTOUT
SEE TABLE 2

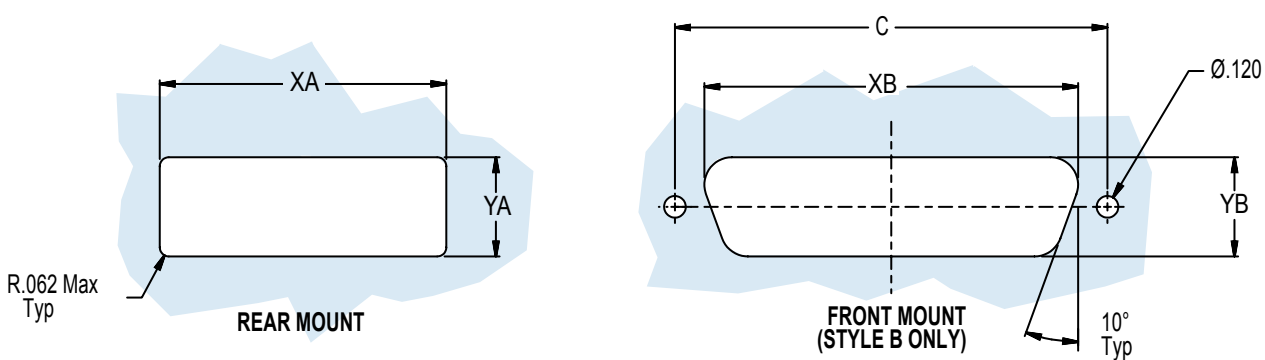

TABLE II: PANEL CUT-OUT					
Shell Sizes	Style A		Style B		
	Dim XA	Dim YA	Dim XB	Dim YB	Dim C
1	.745 (18.9)	.385 (9.8)	.799 (20.0)	.462 (11.7)	.984 (25.0)
2	.950 (24.1)	.385 (9.8)	1.125 (31.8)	.462 (11.7)	1.312 (33.3)
3	1.495 (38.0)	.385 (9.8)	1.690 (42.9)	.482 (12.2)	1.852 (47.0)
4	2.145 (54.5)	.385 (9.8)	2.335 (59.3)	.482 (12.2)	2.500 (63.5)
5	2.015 (51.2)	.520 (13.2)	2.231 (56.7)	.588 (14.9)	2.406 (61.1)

Dimensions in Inches (millimeters) are subject to change without notice.