

Customer Information Sheet

DRAWING No.: M80-328 TO M80-329 SHEET 2 OF 2 IF IN DOUBT - ASK (C) NOT TO SCALE THIRD ANGLE PROJECTION ALL DIMENSIONS IN mm

SPECIFICATIONS:

MATERIALS:

BODY = COPPER ALLOY
 LATCHING COLLAR = BERYLLIUM COPPER

FINISH:

BODY = GOLD
 LATCHING COLLAR = NICKEL

ELECTRICAL:

CONTACT RESISTANCE = $6m\Omega$ MAX
 CURRENT RATING = SEE TABLE (CABLE DEPENDENT)

MECHANICAL:

DURABILITY = 500 OPERATIONS
 INSERTION FORCE = 8N MAX
 WITHDRAWAL FORCE = 0.5N MIN
 CONTACT REPLACEMENT IN INSULATOR = 5 TIMES

ENVIRONMENTAL:

TEMPERATURE RANGE = -55°C TO +125°C

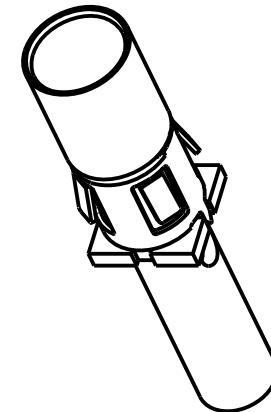
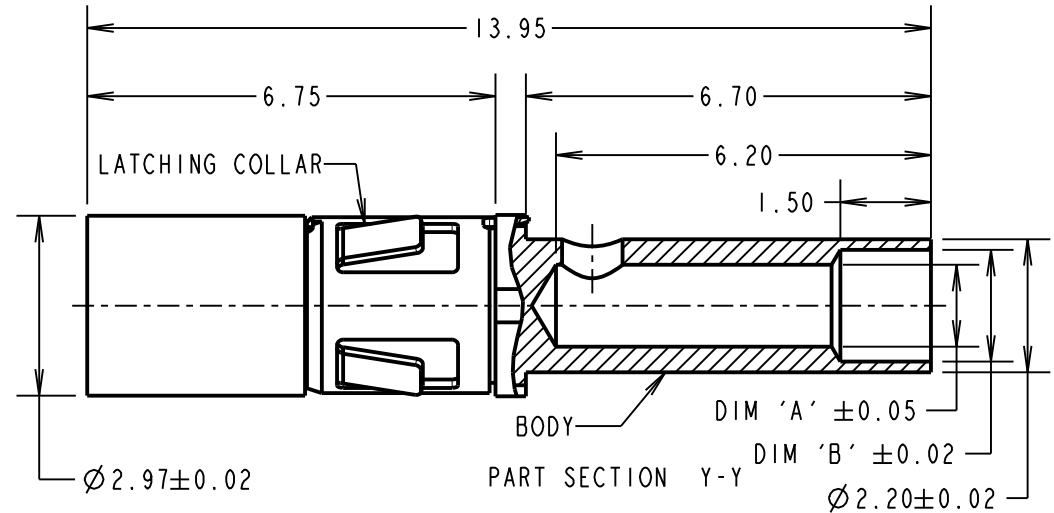
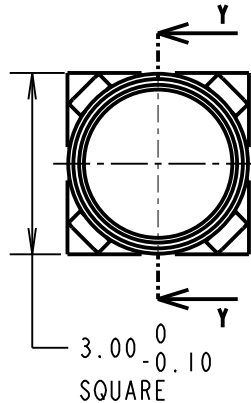

NOTES:

- CONTACT COMES SUPPLIED ASSEMBLED.
- STRIP WIRE BY 5.0mm FOR CRIMPING.
- CONTACT EXTRACTION TOOL = Z80-290.
- RECOMMENDED CRIMP TOOL = Z80-294 AND POSITIONER Z80-295.
- FOR ALL OTHER ELECTRICAL/MECHANICAL REQUIREMENTS, SEE COMPONENT SPECIFICATION C005XX (LATEST ISSUE).

PART No.	DIM 'A'	DIM 'B'	WIRE SIZE	CURRENT RATING
M80-328	∅1.35	∅1.85	18 AWG	8A
M80-329	∅1.10	∅1.65	20 AWG	5A

MGP	3	04.01.13	11898
NAME	ISS.	DATE	C/NOTE
APPROVED: MGP			
CHECKED: SB			
DRAWN: R.ADDE			
CUSTOMER REF.:			
ASSEMBLY DRG:			

HARWIN

www.harwin.com
 technical@harwin.com

THIS DRAWING AND ANY INFORMATION OR DESCRIPTIVE MATTER SET OUT HEREON ARE CONFIDENTIAL AND COPYRIGHT PROPERTY OF THE HARWIN GROUP AND MUST NOT BE DISCLOSED, LOANED, COPIED OR USED FOR MANUFACTURING, TENDERING OR FOR ANY OTHER PURPOSE WITHOUT THEIR WRITTEN PERMISSION.

TOLERANCES
 X. = ±1mm
 X.X = ±0.25mm
 X.XX = ±0.10mm
 X.XXX = ±0.01mm
 ANGLES = ±5°
 UNLESS STATED

MATERIAL:
 SEE ABOVE
FINISH:
S/AREA: mm²

TITLE: DATAMATE MIX-TEK
 POWER CONTACT FEMALE
 STRAIGHT SOLDER OR CRIMP
DRAWING NUMBER:
 M80-328 TO M80-329
 SHT 2 OF 2