



STE-0803-WSK

**SICK**  
Sensor Intelligence.

## Ordering information



Illustration may differ



| Type         | Part no. |
|--------------|----------|
| STE-0803-WSK | 6053170  |

Other models and accessories → [www.sick.com/](http://www.sick.com/)

## Detailed technical data

### Technical specifications

|                                      |  |
|--------------------------------------|--|
| <b>Accessory group</b>               | Plug connectors and cables                   |
| <b>Accessory family</b>              | Field-attachable connectors                  |
| <b>Connection type head A</b>        | Male connector, M8, 3-pin, angled            |
| <b>Connection type</b>               | Screw-type terminals                         |
| <b>Connector material</b>            | PBT  |
| <b>Connector color</b>               | Black  |
| <b>Locking nut material</b>          | Nickel-plated brass                          |
| <b>Tightening torque</b>             | 0.6 Nm                                       |
| <b>Shielding</b>                     | Unshielded                                   |
| <b>Permitted cable diameter</b>      | 3.5 mm ... 5 mm                              |
| <b>Permitted cross-section</b>       | 0.14 mm <sup>2</sup> ... 0.5 mm <sup>2</sup> |
| <b>Reference voltage</b>             | ≤ 60 V                                       |
| <b>Current loading</b>               | 4 A  |
| <b>UL File No.</b>                   | E335179                                      |
| <b>Enclosure rating</b>              | IP67   |
| <b>Ambient operating temperature</b> |  |
|                                      | Head -40 °C ... +85 °C                       |

### Classifications

|                     |          |
|---------------------|----------|
| <b>ECl@ss 5.0</b>   | 27279290 |
| <b>ECl@ss 5.1.4</b> | 27279290 |
| <b>ECl@ss 6.0</b>   | 27279221 |
| <b>ECl@ss 6.2</b>   | 27279221 |
| <b>ECl@ss 7.0</b>   | 27440104 |
| <b>ECl@ss 8.0</b>   | 27440104 |
| <b>ECl@ss 8.1</b>   | 27440104 |
| <b>ECl@ss 9.0</b>   | 27440102 |
| <b>ETIM 5.0</b>     | EC002635 |
| <b>ETIM 6.0</b>     | EC002635 |

UNSPSC 16.0901

39121421

## Dimensional drawing (Dimensions in mm (inch))

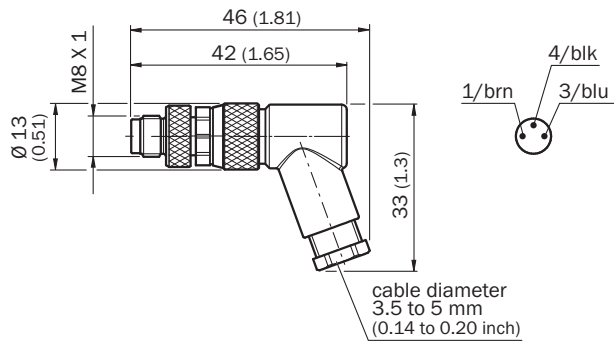

## SICK AT A GLANCE

SICK is one of the leading manufacturers of intelligent sensors and sensor solutions for industrial applications. A unique range of products and services creates the perfect basis for controlling processes securely and efficiently, protecting individuals from accidents and preventing damage to the environment.

We have extensive experience in a wide range of industries and understand their processes and requirements. With intelligent sensors, we can deliver exactly what our customers need. In application centers in Europe, Asia and North America, system solutions are tested and optimized in accordance with customer specifications. All this makes us a reliable supplier and development partner.

Comprehensive services complete our offering: SICK LifeTime Services provide support throughout the machine life cycle and ensure safety and productivity.

For us, that is “Sensor Intelligence.”

## WORLDWIDE PRESENCE:

Contacts and other locations [www.sick.com](http://www.sick.com)