

Rev	AWO #	Description	Date	Appr
-		RELEASED	8/21/09	

APPROVED: _____

DATE: _____ TITLE: _____

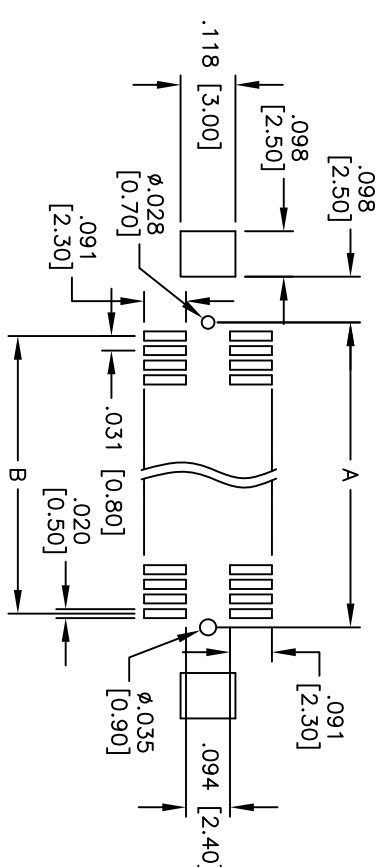
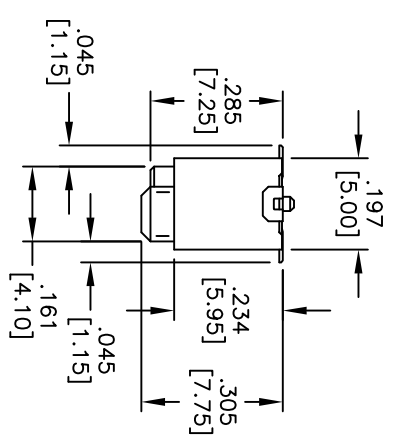
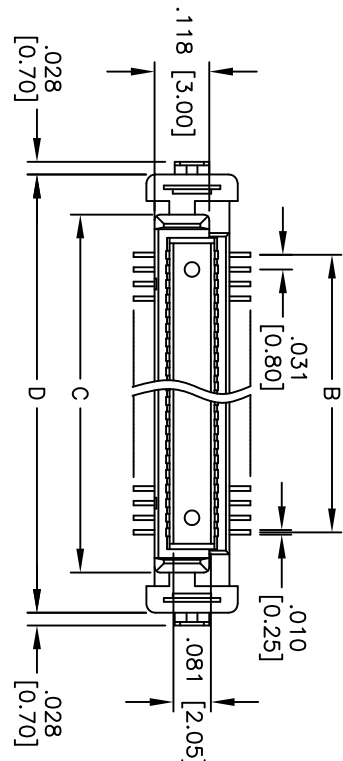
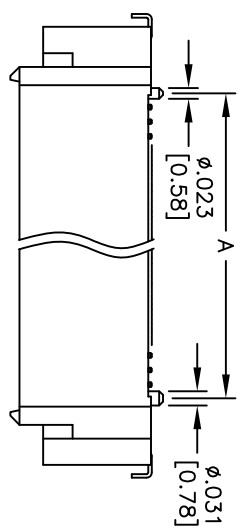

RECOMMENDED PCB LAYOUT

- Positions: 20, 30, 40, 50, 60
- B = .031 [0.80] x (No. of Contacts - 1) + .059 [1.50]
 - A = .031 [0.80] x (No. of Contacts - 1)
 - C = .031 [0.80] x (No. of Contacts - 1) + .173 [4.40]
 - D = .031 [0.80] x (No. of Contacts - 1) + .346 [8.80]

SPECIFICATIONS:
Material: Insulator: Hi-temp thermoplastic, rated UL 94V-0
 Insulator color: Black
 Contacts: Copper Alloy
 Hold down: Copper Alloy
Plating:
 Gold flash over Nickel underplate on contact area,
 Tin over Copper underplate on tails,
Electrical:
 Operating voltage: 200 VAC max.
 Current rating: 0.5 Amps max.
 Contact resistance: 70 mohms max. initial
 Insulation resistance: 100 Mohms min.
Environmental:
 Lead free, RoHS compliant
 Recommended soldering temp: 260°C for 5 seconds



UNLESS OTHERWISE SPECIFIED ALL DIMENSIONS ARE INCHES [MM]	
TOLERANCES: EXCEPT AS NOTED	
INCHES	HOLDS
.X ± .10	ØXX ± .10
.XX ± .020	ØXXX ± .015
.XXX ± .015	ØXXXX ± .010
APPROVALS	DATE
DRAWN	DY
CHECKED	
APPROVED	

ADAM TECH
 909 Railway Avenue, Union, NJ 07083
 Phone: 908-687-5000 Fax: 908-687-5710

TITLE: .031 [0.80] BOARD TO BOARD PLUG
 .305 [7.75] HEIGHT, SMT TYPE

SIZE	PART NO.	REV.
X	BB8-P-XX-SG-.305	-
REF: S0028T	SCALE: NTS	SHEET 1 OF 1