



## CMOS Boost Converter – White LED Driver



### FEATURES

- Drives up to 5 White LEDs from 3V
- Power Efficiency up to 87%
- Low Quiescent Ground Current 0.1mA
- Adjustable Output Current (up to 30mA)
- High Frequency 1MHz Operation
- “Zero” current shutdown mode
- Operates down to 2V (from two AA batteries)
- Soft start power-up
- Open LED low power mode
- Automatic shutdown at 1.9V (UVLO)
- Thermal shutdown protection
- Thin SOT23 5-Lead (1mm max height)

### APPLICATIONS

- LCD Backlighting
- Cellular Phones
- Handheld Devices
- Digital Cameras

### ORDERING INFORMATION

| Part Number   | Package                 | Quantity per Reel | Package Marking |
|---------------|-------------------------|-------------------|-----------------|
| CAT4137TD-T3  | TSOT23-5 <sup>(1)</sup> | 3000              | LX              |
| CAT4137TD-GT3 | TSOT23-5 <sup>(2)</sup> | 3000              | UE              |

Notes: (1) Matte-Tin Plated Finish (RoHS-compliant).  
(2) NiPdAu Plated Finish (RoHS-compliant).

### PIN CONFIGURATION

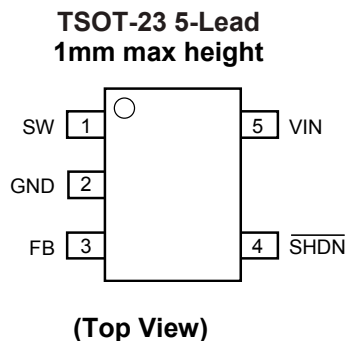

### DESCRIPTION

The CAT4137 is a DC/DC step-up converter that delivers a regulated output current. Operation at a constant switching frequency of 1MHz allows the device to be used with small value external ceramic capacitors and inductor.

The device drives a string of white LEDs connected in series and provides the regulated current to control the LEDs with inherent uniform brightness and matching. An external resistor R1 sets the output current and allows up to 30mA current to be supported over a wide range of input supply voltages from 2.2V to 5.5V, making the device ideal for battery-powered applications.

LED dimming can be done by using a DC voltage, a logic signal, or a pulse width modulation (PWM) signal. The shutdown control pin allows the device to be placed in power-down mode with “zero” quiescent current.

In addition to thermal protection and overload current limiting, the device also enters a very low power operating mode during “Open LED” fault conditions. The device is housed in a low profile (1mm max height) 5-lead thin SOT23 package for space critical applications.

For Ordering Information details see page 15.

### TYPICAL APPLICATION CIRCUIT

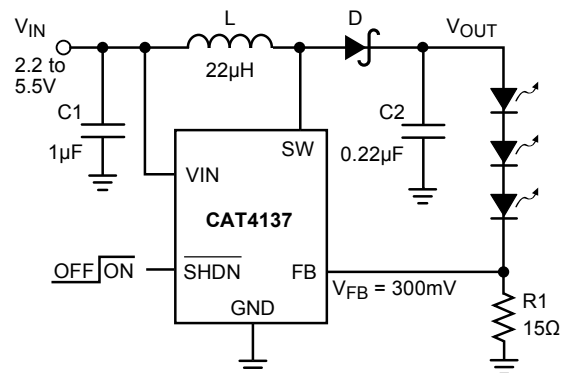

L: Murata LQH32CN220  
D: Central CMDSH2-3 (rated 30V)

**ABSOLUTE MAXIMUM RATINGS**

| Parameter                        | Rating      | Unit |
|----------------------------------|-------------|------|
| V <sub>IN</sub> , FB voltage     | -0.3 to +7  | V    |
| $\overline{\text{SHDN}}$ voltage | -0.3 to +7  | V    |
| SW voltage                       | -0.3 to 40  | V    |
| Storage Temperature Range        | -65 to +160 | °C   |
| Junction Temperature Range       | -40 to +150 | °C   |
| Lead Temperature                 | 300         | °C   |

**RECOMMENDED OPERATING CONDITIONS**

| Parameter                 | Range      | Unit |
|---------------------------|------------|------|
| V <sub>IN</sub>           | 2.2 to 5.5 | V    |
| SW pin voltage            | 0 to 24    | V    |
| Ambient Temperature Range | -40 to +85 | °C   |
| LED Bias Current          | 1 to 30    | mA   |

**ELECTRICAL OPERATING CHARACTERISTICS**

V<sub>IN</sub> = 3.6V, ambient temperature of 25°C (over recommended operating conditions unless specified otherwise)

| Symbol                             | Parameter   | Conditions   | Min                 | Typ            | Max                 | Unit   |
|------------------------------------|---|--|---------------------|----------------|---------------------|--------|
| I <sub>Q</sub>                     | Operating Current   | V <sub>FB</sub> = 0.3V<br>V <sub>FB</sub> = 0.4V (not switching) |                     | 0.4<br>0.1     | 1.5<br>0.3          | mA     |
| I <sub>SD</sub>                    | Shutdown Current  | V <sub>SHDN</sub> = 0V   |                     | 0.1            | 1                   | µA     |
| V <sub>FB</sub>                    | FB Pin Voltage  | 3 LEDs with I <sub>LED</sub> =20mA                               | 285                 | 300            | 315                 | mV     |
| I <sub>FB</sub>                    | FB pin input leakage  |  |                     | 0.1            | 1                   | µA     |
| I <sub>LED</sub>                   | Programmed LED Current  | R1 = 10Ω<br>R1 = 15Ω<br>R1 = 20Ω                                 | 28.5<br>19<br>14.25 | 30<br>20<br>15 | 31.5<br>21<br>15.75 | mA     |
| V <sub>IH</sub><br>V <sub>IL</sub> | $\overline{\text{SHDN}}$ Logic High<br>$\overline{\text{SHDN}}$ Logic Low | Enable Threshold Level<br>Shutdown Threshold Level               | 0.4                 | 0.8<br>0.7     | 1.5                 | V<br>V |
| F <sub>SW</sub>                    | Switching Frequency   |  | 0.7                 | 1              | 1.3                 | MHz    |
| I <sub>LIM</sub>                   | Switch Current Limit  |  | 250                 | 300            | 400                 | mA     |
| R <sub>SW</sub>                    | Switch “On” Resistance  | I <sub>SW</sub> = 100mA  |                     | 1.0            | 2.0                 | Ω      |
| I <sub>LEAK</sub>                  | Switch Leakage Current  | Switch Off, V <sub>SW</sub> = 5V                                 |                     | 1              | 5                   | µA     |
| T <sub>SD</sub>                    | Thermal Shutdown  |  |                     | 150            |                     | °C     |
| T <sub>HYS</sub>                   | Thermal Hysteresis  |  |                     | 20             |                     | °C     |
| η                                  | Efficiency  | Typical Application Circuit                                      |                     | 86             |                     | %      |
| V <sub>UVLO</sub>                  | Under-voltage lock out (UVLO) threshold                                   |  |                     | 1.9            |                     | V      |
| V <sub>OV-SW</sub>                 | Output Clamp Voltage  | “Open LED” fault   |                     | 29             |                     | V      |

**TYPICAL CHARACTERISTICS**

$V_{IN} = 3.6V$ ,  $C_{IN} = 1.0\mu F$ ,  $C_{OUT} = 0.22\mu F$ ,  $L = 22\mu H$  with 3 LEDs at 20mA,  $T_{AMB} = 25^{\circ}C$ , unless otherwise specified.

**Quiescent Current vs. VIN (Not Switching)**

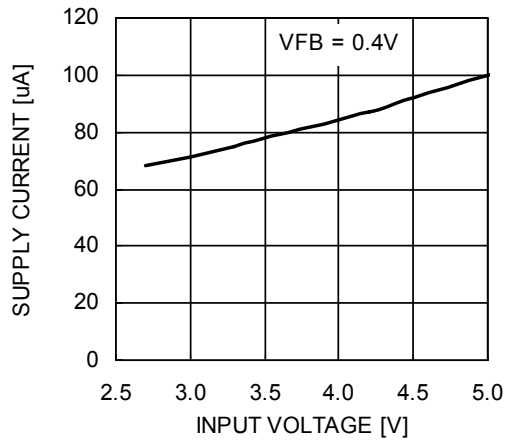

**Quiescent Current vs. VIN (Switching)**

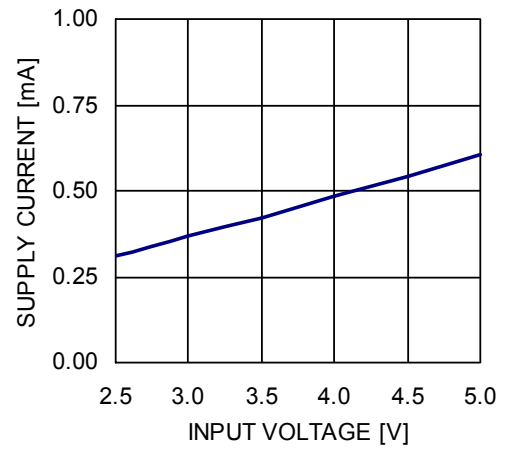

**FB Pin Voltage vs. Supply Voltage**

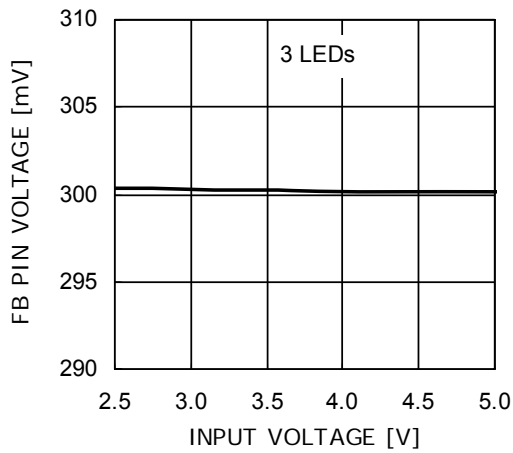

**FB Pin Voltage vs. Output Current**

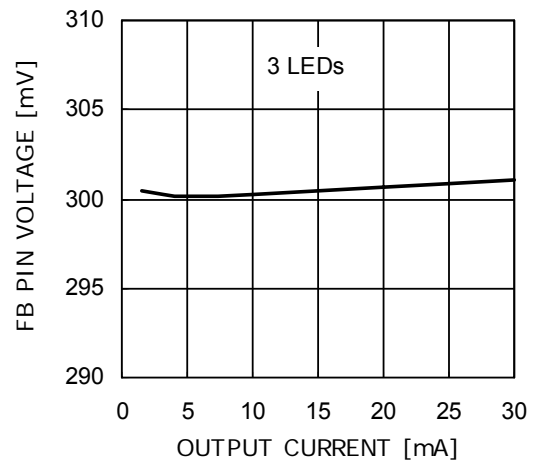

**Switching Frequency vs. Supply Voltage**

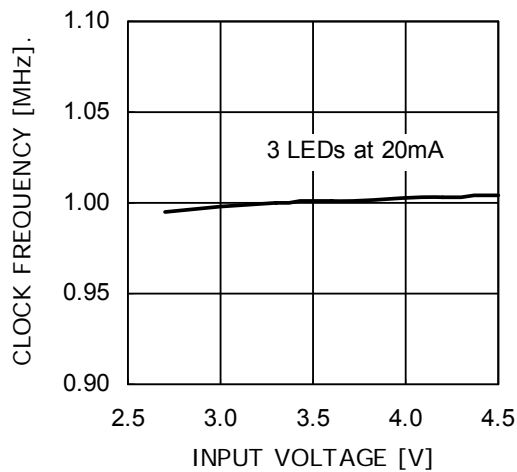

**Switch ON Resistance vs. Input Voltage**

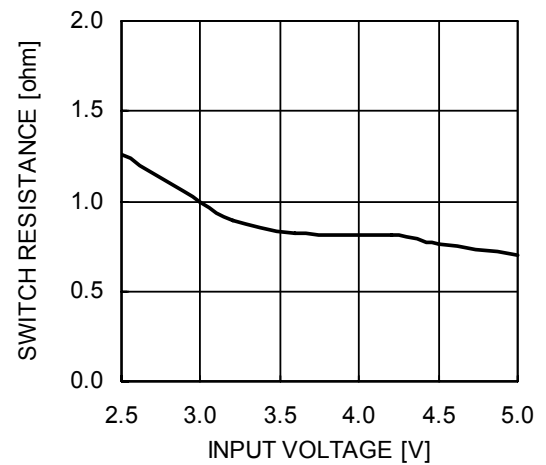

**TYPICAL CHARACTERISTICS**

$V_{IN} = 3.6V$ ,  $C_{IN} = 1.0\mu F$ ,  $C_{OUT} = 0.22\mu F$ ,  $L = 22\mu H$ , with 3 LEDs at 20mA,  $T_{AMB}=25^{\circ}C$ , unless otherwise specified.

**LED Current vs. Input Voltage (3 LEDs)**

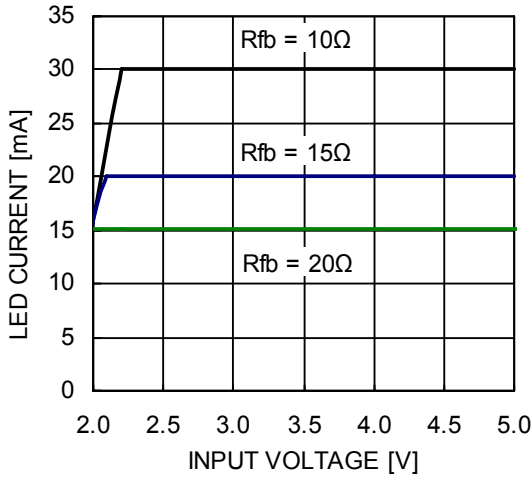

**LED Current Regulation**

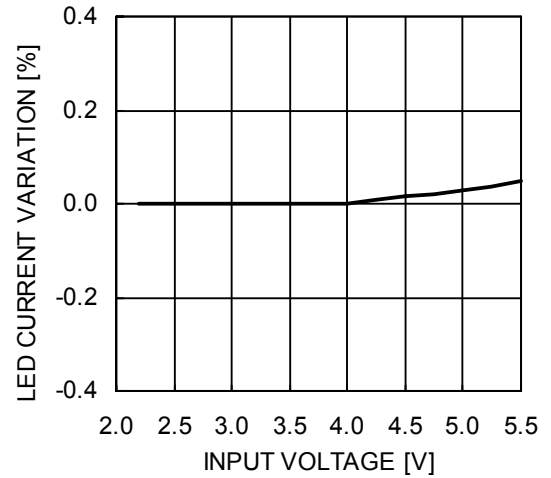

**Efficiency across Supply Voltage (3 LEDs)**

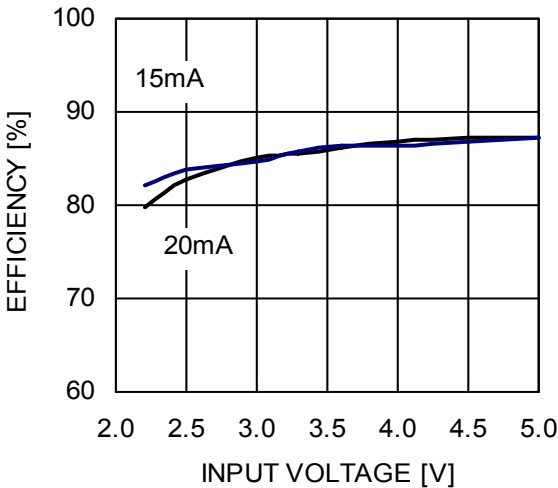

**Efficiency across Load Current (3 LEDs)**

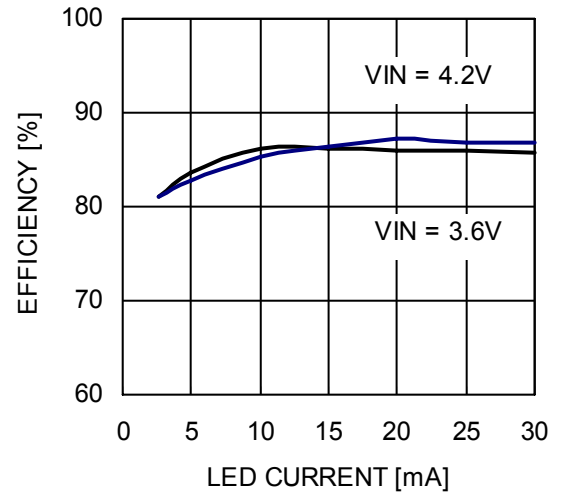

**Efficiency across Supply Voltage (4 LEDs)**

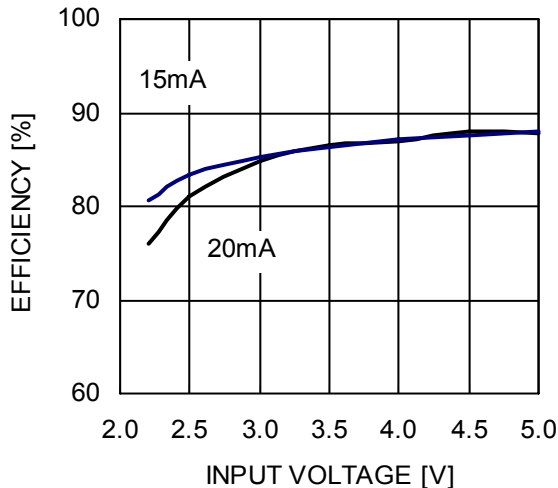

**Efficiency across Load Current (4 LEDs)**

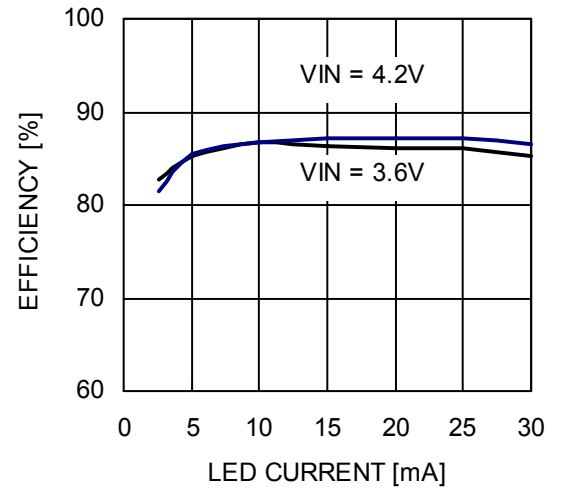

**TYPICAL CHARACTERISTICS**

$V_{IN} = 3.6V$ ,  $C_{IN} = 1.0\mu F$ ,  $C_{OUT} = 0.22\mu F$ ,  $L = 22\mu H$ , with 3 LEDs at 20mA,  $T_{AMB}=25^{\circ}C$ , unless otherwise specified.

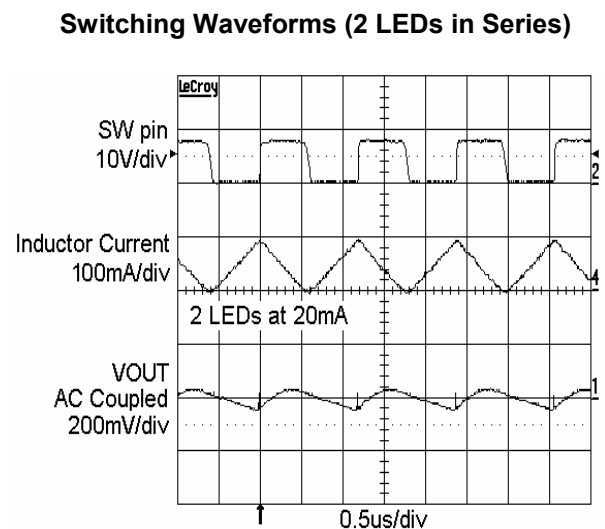
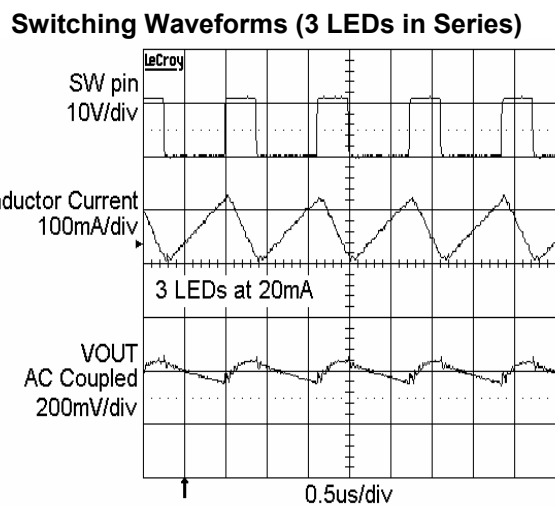
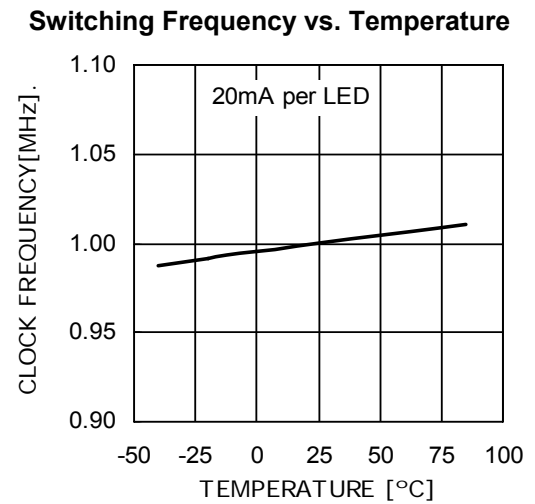
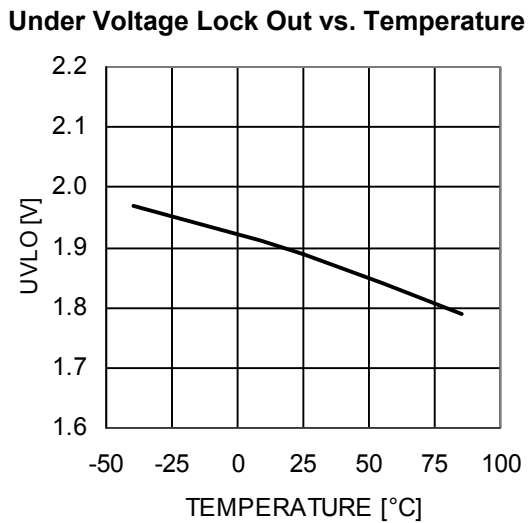
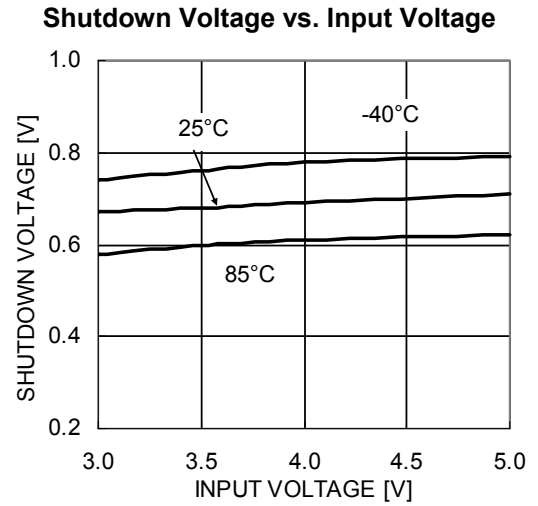
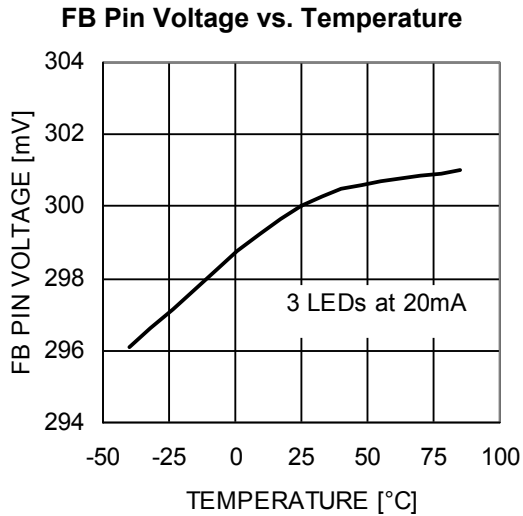

**TYPICAL CHARACTERISTICS**

$V_{IN} = 3.6V$ ,  $C_{IN} = 1.0\mu F$ ,  $C_{OUT} = 0.22\mu F$ ,  $L = 22\mu H$ , with 3 LEDs at 20mA,  $T_{AMB} = 25^{\circ}C$ , unless otherwise specified.

**Power-up with 3 LEDs at 20mA**

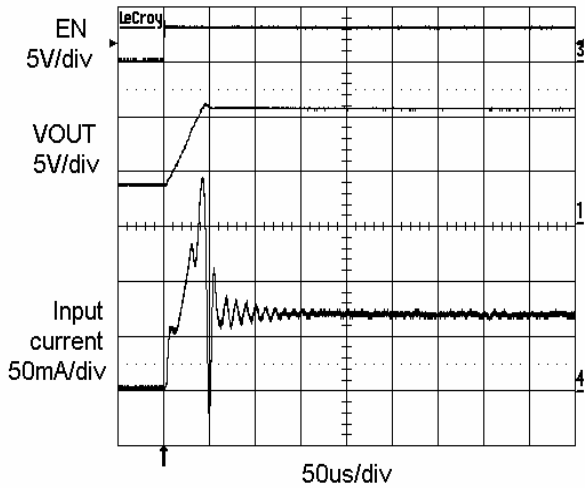

**Line Transient Response (3V – 5.5V)**

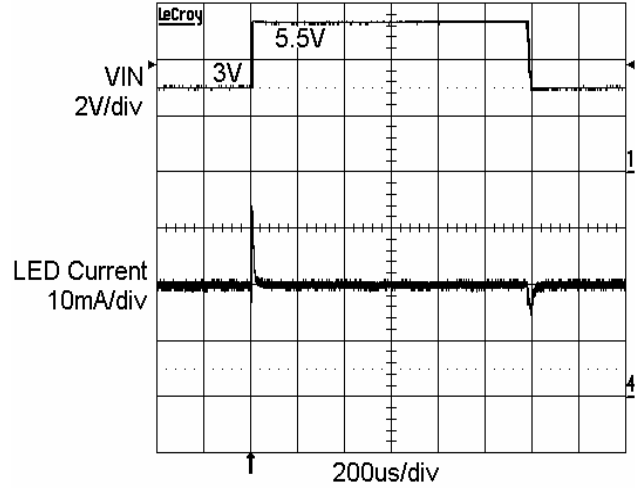

**Maximum Output Current vs. Input Voltage**

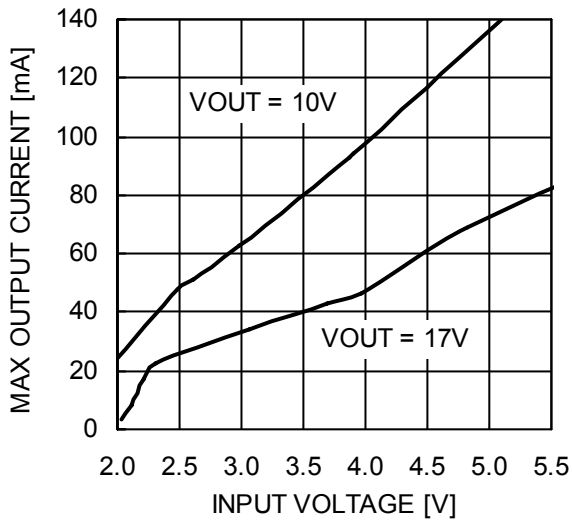

## PIN DESCRIPTION

**VIN** is the supply input for the internal logic. The device is compatible with supply voltages down to 2.2V and up to 5.5V. A small bypass ceramic capacitor of 1 $\mu$ F is recommended between the VIN and GND pins near the device. The under-voltage lockout (UVLO) circuitry will place the device into an idle mode (not switching) whenever the supply falls below 1.9V.

**$\overline{\text{SHDN}}$**  is the shutdown logic input. When the pin voltage is taken below 0.4V, the device immediately enters shutdown mode, drawing nearly zero current. At voltages greater than 1.5V, the device becomes fully enabled and operational.

**GND** is the ground reference pin. This pin should be connected directly to the ground plane on the PCB.

**SW** pin is the drain terminal of the internal low resistance power switch. The inductor and the Schottky diode anode should be connected to the SW pin. Traces going to the SW pin should be as short as possible with minimum loop area. This pin contains over-voltage circuitry which becomes active above 24V. In the event of an "Open-Led" fault condition, the device will enter a low power mode and the SW pin will be clamped to approximately 30V.

**FB** feedback pin is regulated at 0.3V. A resistor connected between the FB pin and ground sets the LED current according to the formula:

$$I_{\text{LED}} = 0.3V/R1$$

The lower LED cathode is connected to the FB pin.

| Pin # | Name                     | Function  |
|-------|--------------------------|---|
| 1     | SW                       | Switch pin. This is the drain of the internal power switch. |
| 2     | GND                      | Ground pin. Connect the pin to the ground plane.            |
| 3     | FB                       | Feedback pin. Connect to the last LED cathode.              |
| 4     | $\overline{\text{SHDN}}$ | Shutdown pin (Logic Low). Set high to enable the driver.    |
| 5     | VIN                      | Power Supply input.   |

**DEVICE OPERATION**

The CAT4137 is a fixed frequency (1MHz), low noise, inductive boost converter providing constant current to the load. A high voltage internal CMOS power switch is used to energize the external inductor. When the power switch is then turned off, the stored energy inductor is released into the load via the external Schottky diode.

The on/off duty cycle of the power switch is internally adjusted and controlled to maintain a constant regulated voltage of 0.3V across the external feedback resistor connected to the feedback pin (FB). The value of external resistor will accurately set the LED bias current accordingly ( $0.3V/R1$ ).

During the initial power-up stage, the duty cycle of the internal power switch is limited to prevent excessive in-rush currents and thereby provide a “soft-start” mode of operation.

While in normal operation, the device will comfortably deliver up to 30mA of bias current into a string of up to 5 white LEDs.

In the event of a “Open-Led” fault condition, where the feedback control loop becomes open, the output voltage will continue to increase. Once this voltage exceeds 24V, an internal protection circuit will become active and place the device into a very low power safe operating mode. In addition, an internal clamping circuit will limit the peak output voltage to 29V. If this fault condition is repaired, the device will automatically resume normal operation.

Thermal overload protection circuitry has been included to prevent the device from operating at unsafe junction temperatures above 150°C. In the event of a thermal overload condition the device will automatically shutdown and wait till the junction temperatures cools to 130°C before normal operation is resumed.

**BLOCK DIAGRAM**

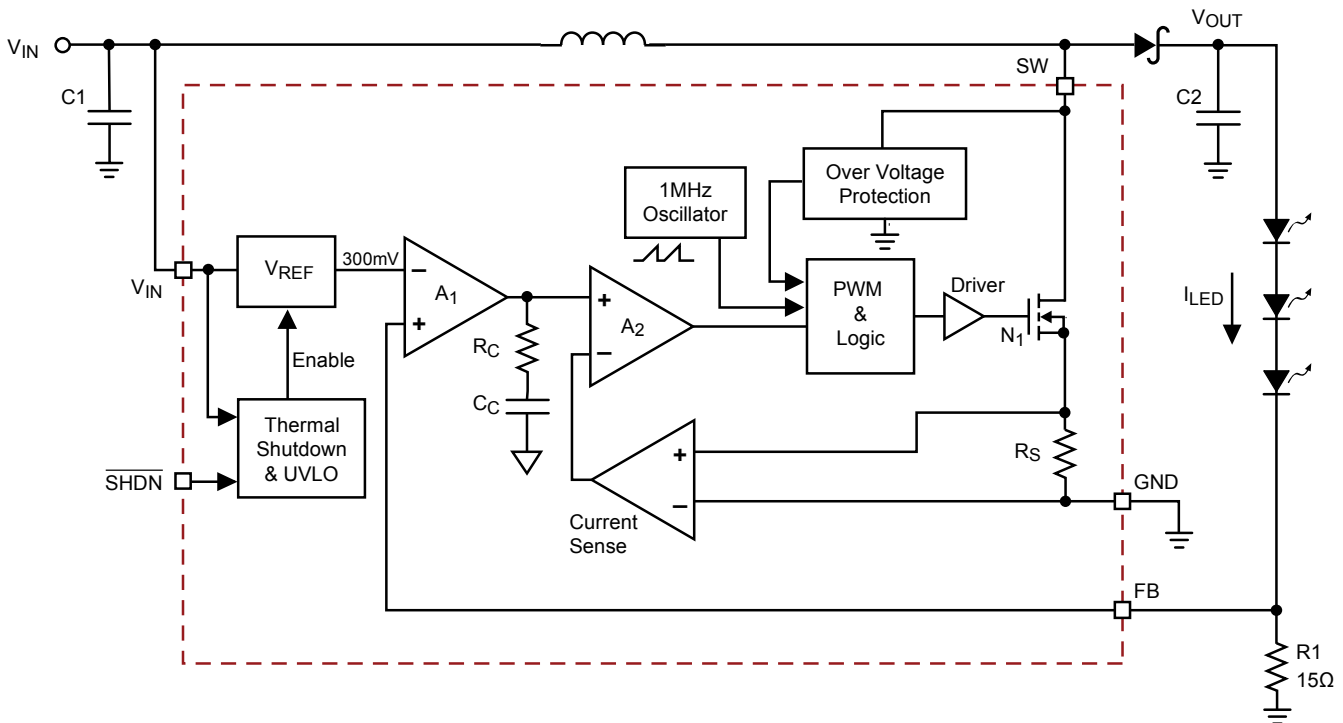



## APPLICATION INFORMATION

### EXTERNAL COMPONENT SELECTION

#### Capacitors

The CAT4137 only requires small ceramic capacitors of 1 $\mu$ F on the input and 0.22 $\mu$ F on the output. The output capacitor should be rated at 30V or greater. Under normal conditions, a 1 $\mu$ F input capacitor is sufficient. For applications with higher output power, a larger input capacitor of 2.2 $\mu$ F or 4.7 $\mu$ F may be appropriate. X5R and X7R capacitor types are ideal due to their stability across temperature range.

#### Inductor

A 22 $\mu$ H inductor is recommended for most of the CAT4137 applications. In cases where the efficiency is critical, inductances with lower series resistance are preferred. Several inductor types from various vendors can be used. Figure 1 shows how different inductor types affect the efficiency across the load range.

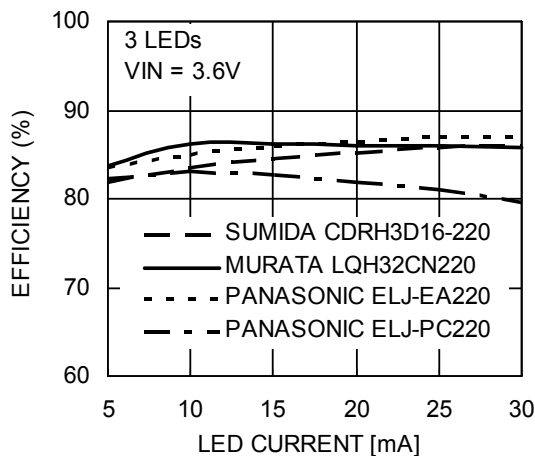

Figure 1. Efficiency for various inductors

#### Schottky Diode

The current rating of the Schottky diode must exceed the peak current flowing through it. The Schottky diode performance is rated in terms of its forward voltage at a given current. In order to achieve the best efficiency, this forward voltage should be as low as possible. The response time is also critical since the driver is operating at 1MHz. Central Semiconductor Schottky CMDSH2-3 (200mA rated) or the CMDSH-3 (100mA rated) is recommended for most applications.

#### LED Current Setting

The LED current is set by the external resistor between the feedback pin (FB) and ground. The formula below gives the relationship between the resistor and the current:

$$R1 = 0.3V / \text{LED current}$$

| LED current (mA) | R1 ( $\Omega$ ) |
|------------------|-----------------|
| 5                | 60              |
| 10               | 30              |
| 15               | 20              |
| 20               | 15              |
| 25               | 12              |
| 30               | 10              |

Table 1. Resistor R1 and LED current

TYPICAL APPLICATIONS

CAT4137 Driving Two LEDs

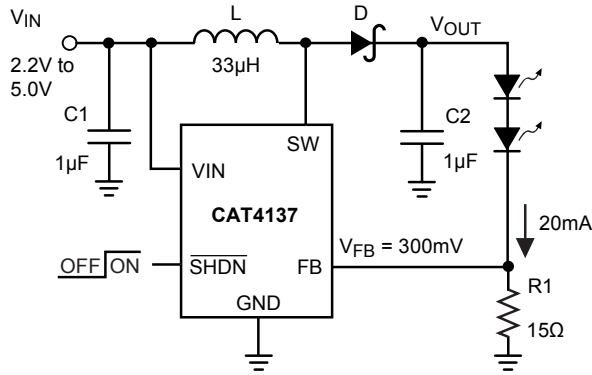

- L: Sumida CDRH3D16-330
- D: Central CMDSH2-3 (rated 30V)
- C2: Taiyo Yuden GMK212BJ105KG-T (rated 35V)

For best performance, a 33µH inductor and a 1µF output capacitor are recommended for 2-LED applications.

In 2-LED configuration, the CAT4137 can be powered from two AA alkaline cells or from a Li-ion battery.

Efficiency vs. LED Current, Two LEDs

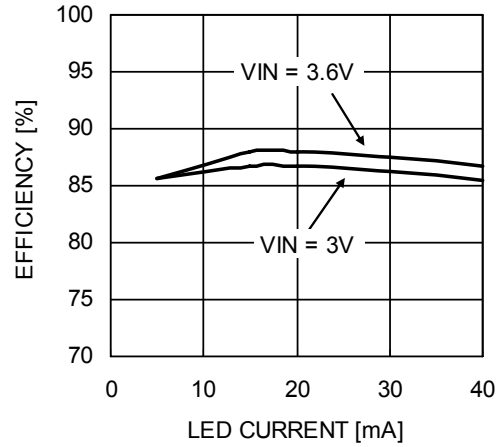

**DIMMING CONTROL**

There are several methods available to control the LED brightness.

**1. PWM signal on the  $\overline{\text{SHDN}}$  pin**

LED brightness dimming can be done by applying a PWM signal to the  $\overline{\text{SHDN}}$  input. The LED current is repetitively turned on and off, so that the average current is proportional to the duty cycle. A 100% duty cycle, with  $\overline{\text{SHDN}}$  always high, corresponds to the LEDs at nominal current. Figures 2 and 3 show 1kHz and 4kHz signals with a 50% duty cycle applied to the  $\overline{\text{SHDN}}$  pin. The PWM frequency range is from 100Hz to 10kHz. The recommended PWM frequency range is from 100Hz to 4kHz.

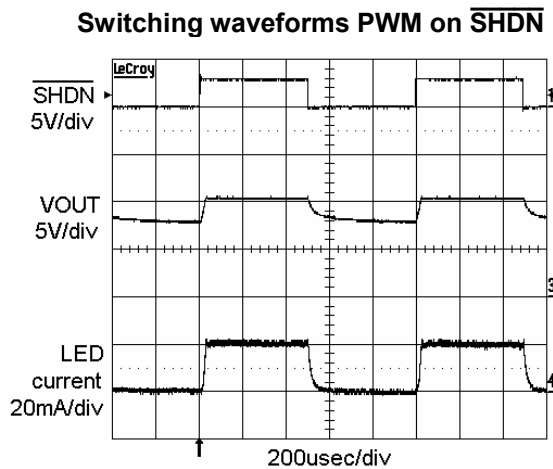

Figure 2. PWM at 1kHz

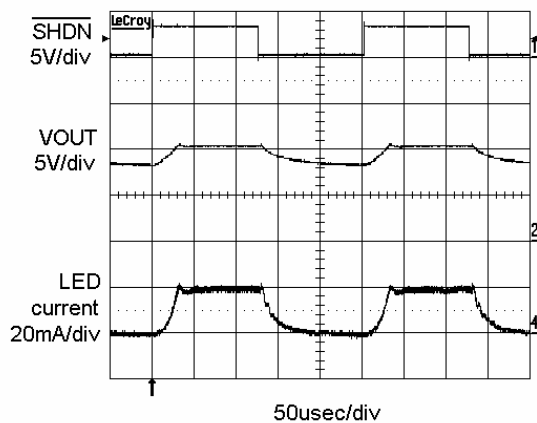

Figure 3. PWM at 4kHz

**2. Filtered PWM signal**

A filtered PWM signal can be used as a variable DC voltage that can be used to control the LED current. Figure 4 shows the PWM control circuitry connected to the CAT4137 FB pin. The PWM signal has a voltage swing of 0V to 2.5V. The LED current can be dimmed within a range from 0 to 22mA. The PWM signal frequency can vary from very low frequency up to 100kHz.

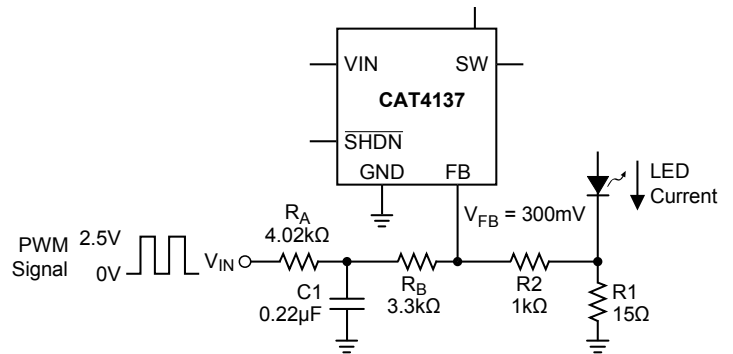
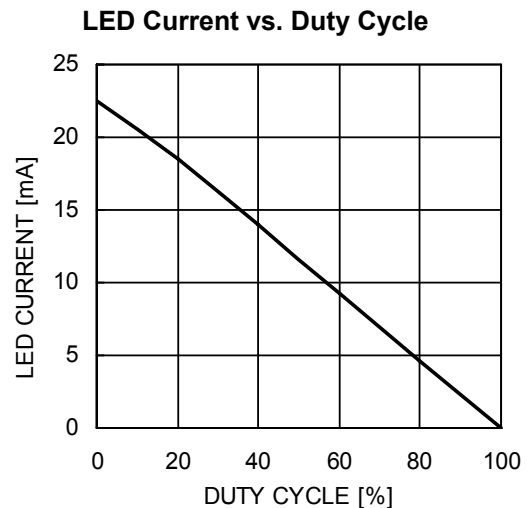

Figure 4. Circuit for filtered PWM signal

A PWM signal at 0V DC, or a 0% duty cycle, results in a max LED current of about 22mA. A PWM signal with a 100% duty cycle results in an LED current of 0mA.



**OPEN LED PROTECTION**

In the event of an “Open LED” fault condition, the CAT4137 will continue to boost the output voltage with maximum power until the output voltage reaches approximately 24V. Once the output exceeds this level, internal circuitry immediately places the device into a very low power mode where the total input power consumed is less than 10mW.

In low power mode, the input supply current will typically drop to 2mA. An internal clamping circuit will limit the subsequent output voltage to approximately 29V. This operating mode eliminates the need for any external protection zener diode. This protection scheme also fully protects the device against any malfunction in the external Schottky diode (open-circuit).

**Open LED Protection**

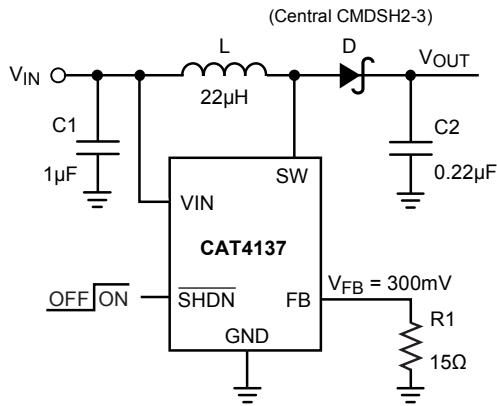

**Open LED Power-up Waveforms**

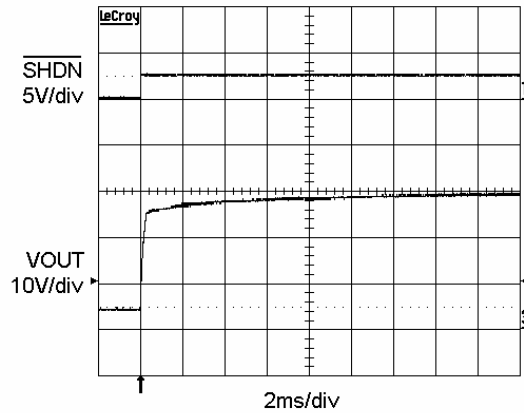

**Open LED Supply Current vs. VIN**

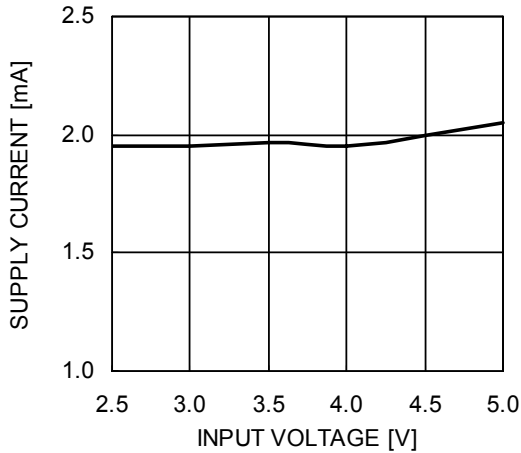

**BOARD LAYOUT**

The CAT4137 is a high-frequency switching regulator. Traces carrying high-frequency switching current have to be carefully layout on the board in order to minimize EMI, ripple and noise in general. The thicker lines shown on Figure 4 indicate the switching current path. All these traces have to be short and wide enough to minimize the parasitic inductance and resistance. The loop shown on Figure 4 corresponds to the current path when the CAT4137 internal switch is closed. On Figure 5 is shown the current loop when the CAT4137 switch is open. Both loop areas should be as small as possible.

Capacitor C1 has to be placed as close as possible to the VIN pin and GND. The capacitor C2 has to be connected separately to the top LED anode. A ground plane under the CAT4137 allows for direct connection of the capacitors to ground. The resistor R1 must be connected directly to the GND pin of the CAT4137 and not shared with the switching current loops and any other components.

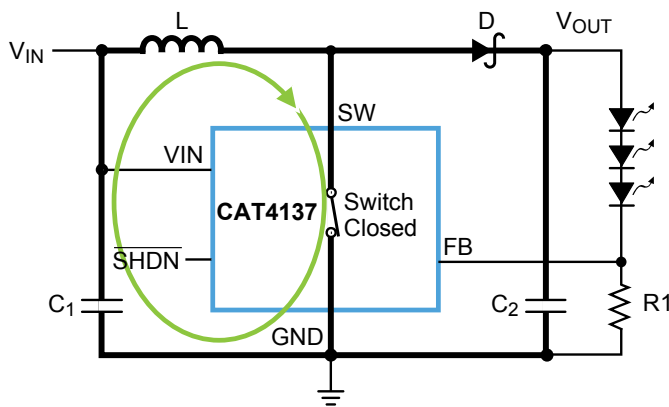

**Figure 4. Closed-switch current loop**

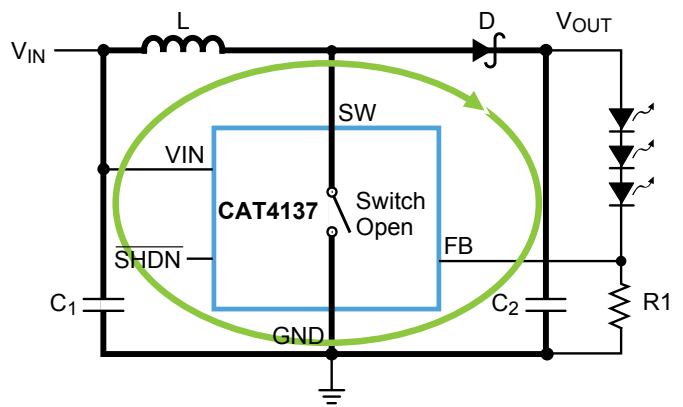

**Figure 5. Open-switch current loop**

PACKAGE OUTLINE DRAWING

TSOT-23 5-Lead (TD) <sup>(1)(2)</sup>

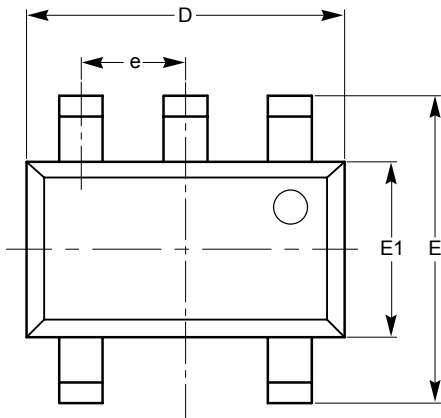

TOP VIEW

| SYMBOL   | MIN      | NOM  | MAX  |
|----------|----------|------|------|
| A        |          |      | 1.00 |
| A1       | 0.01     | 0.05 | 0.10 |
| A2       | 0.80     | 0.87 | 0.90 |
| b        | 0.30     |      | 0.45 |
| c        | 0.12     | 0.15 | 0.20 |
| D        | 2.90 BSC |      |      |
| E        | 2.80 BSC |      |      |
| E1       | 1.60 BSC |      |      |
| e        | 0.95 TYP |      |      |
| L        | 0.30     | 0.40 | 0.50 |
| L1       | 0.60 REF |      |      |
| L2       | 0.25 BSC |      |      |
| $\theta$ | 0°       |      | 8°   |

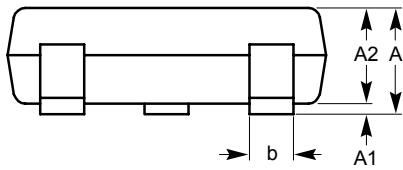

SIDE VIEW

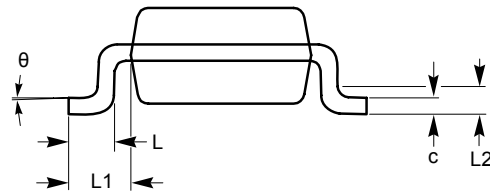

END VIEW

For current Tape and Reel information, download the PDF file from:  
<http://www.catsemi.com/documents/tapeandreel.pdf>.

Notes:

- (1) All dimensions are in millimeters. Angles in degrees.
- (2) Complies with JEDEC standard MO-193.

**EXAMPLE OF ORDERING INFORMATION**

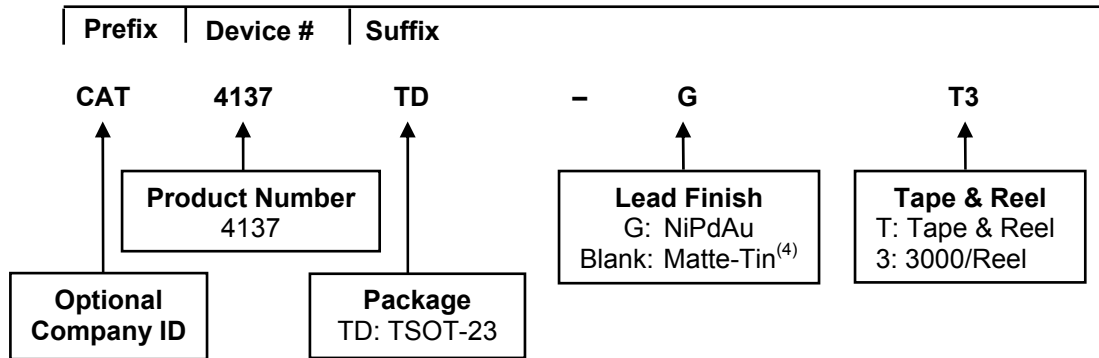

**Notes:**

- (1) All packages are RoHS-compliant (Lead-free, Halogen-free).
- (2) The standard lead finish is NiPdAu.
- (3) The device used in the above example is a CAT4137TD-GT3 (TSOT-23, NiPdAu Plated Finish, Tape & Reel 3000).
- (4) For Matte-Tin package option, please contact your nearest ON Semiconductor Sales office.

**REVISION HISTORY**

| Date      | Rev. | Reason   |
|-----------|------|--|
| 13-Dec-05 | 00   | Initial Issue  |
| 11-Jan-08 | B    | Add NiPdAu lead finish<br>Add Extended Temperature range<br>Update Package Outline Drawing<br>Add Example of Ordering Information<br>Change Document Number from 25093, Rev. 00 to MD-5016, Rev. B |
| 17-Nov-08 | C    | Change logo and fine print to ON Semiconductor   |

ON Semiconductor and  are registered trademarks of Semiconductor Components Industries, LLC (SCILLC). SCILLC reserves the right to make changes without further notice to any products herein. SCILLC makes no warranty, representation or guarantee regarding the suitability of its products for any particular purpose, nor does SCILLC assume any liability arising out of the application or use of any product or circuit, and specifically disclaims any and all liability, including without limitation special, consequential or incidental damages. "Typical" parameters which may be provided in SCILLC data sheets and/or specifications can and do vary in different applications and actual performance may vary over time. All operating parameters, including "Typicals" must be validated for each customer application by customer's technical experts. SCILLC does not convey any license under its patent rights nor the rights of others. SCILLC products are not designed, intended, or authorized for use as components in systems intended for surgical implant into the body, or other applications intended to support or sustain life, or for any other application in which the failure of the SCILLC product could create a situation where personal injury or death may occur. Should Buyer purchase or use SCILLC products for any such unintended or unauthorized application, Buyer shall indemnify and hold SCILLC and its officers, employees, subsidiaries, affiliates, and distributors harmless against all claims, costs, damages, and expenses, and reasonable attorney fees arising out of, directly or indirectly, any claim of personal injury or death associated with such unintended or unauthorized use, even if such claim alleges that SCILLC was negligent regarding the design or manufacture of the part. SCILLC is an Equal Opportunity/Affirmative Action Employer. This literature is subject to all applicable copyright laws and is not for resale in any manner.

**PUBLICATION ORDERING INFORMATION**

**LITERATURE FULFILLMENT:**

**Literature Distribution Center for ON Semiconductor**  
P.O. Box 5163, Denver, Colorado 80217 USA  
**Phone:** 303-675-2175 or 800-344-3860 Toll Free USA/Canada  
**Fax:** 303-675-2176 or 800-344-3867 Toll Free USA/Canada  
**Email:** orderlit@onsemi.com

**N. American Technical Support:** 800-282-9855 Toll Free USA/Canada  
**Europe, Middle East and Africa Technical Support:**  
Phone: 421 33 790 2910  
**Japan Customer Focus Center:**  
Phone: 81-3-5773-3850

**ON Semiconductor Website:** [www.onsemi.com](http://www.onsemi.com)  
**Order Literature:** <http://www.onsemi.com/orderlit>  
For additional information, please contact your local Sales Representative