

**Technical Data Sheet**

**Hyper Mini Top View LEDs**

**45-11-BFP-9GABBBA6F-2T8-AM**

**Lead (Pb) Free Product - RoHS Compliant**



**Feature**

- RoHS compliant.
- P-LCC-2 package.
- Colored diffused resin.
- Wide viewing angle 120°.
- Inner reflector and white package .
- Brightness: 1120 to 2800 mcd at 30 mA.
- Qualification according to AEC-Q101 rev C.
- Precondition: Bases on JEDEC J-STD 020D Level 3.
- Useable in severe lead free processes with automotive reflow profile (IR reflow or wave soldering)

**Applications**

- Automotive backlighting or indicator: Dashboard, switch, audio and video equipments... etc.
- Backlight: LCD, switches, symbol, mobile phone and illuminated advertising.
- Display for indoor and outdoor application.
- Ideal for coupling into light guides.
- Substitution of traditional light.
- Optical indicator.
- General applications.

**Device Selection Guide**

Chip	Emitted Color	Resin Color
Material		
InGaN	Ice Blue	Yellowish

Technical Data Sheet

Hyper Mini Top View LEDs

**45-11-BFP-9GABBBA6F-2T8-AM**

Absolute Maximum Ratings (Ta=25°C)

Parameter	Symbol	Rating	Unit
Forward Current	I <sub>F</sub>	30	mA
Peak Forward Current (Duty 1/10 @1KHz)	I <sub>FP</sub>	100	mA
Power Dissipation	P <sub>d</sub>	100	mW
Junction Temperature	T <sub>j</sub>	115	°C
Operating Temperature	T <sub>opr</sub>	-40 ~ +100	°C
Storage Temperature	T <sub>stg</sub>	-40 ~ +110	°C
Thermal Resistance	R <sub>th J-A</sub>	300	K/W
	R <sub>th J-S</sub>	180	K/W
ESD (Classification acc. AEC Q101)	ESD <sub>HBM</sub>	2000	V
	ESD <sub>MM</sub>	200	V
Soldering Temperature	T <sub>sol</sub>	Reflow Soldering : 260 °C for 30 sec. Hand Soldering : 350 °C for 3 sec.	

Technical Data Sheet

Hyper Mini Top View LEDs

**45-11-BFP-9GABBBA6F-2T8-AM**

Electro-Optical Characteristics (Ta=25°C)

Parameter	Symbol	Min.	Typ.	Max.	Unit	Condition
Luminous Intensity	$I_v$	1400	---	2800	mcd	$I_F = 30\text{mA}$
Viewing Angle	$2\theta_{1/2}$	---	120	---	deg	$I_F = 30\text{mA}$
Forward Voltage	$V_F$	2.75	---	3.95	V	$I_F = 30\text{mA}$
Temperature coefficient of $\lambda_p$	$TC_{\lambda_p}$	---	0.03	---	nm/K	$I_F = 30\text{mA}$
Temperature coefficient of $\lambda_d$	$TC_{\lambda_d}$	---	0.02	---	nm/K	$I_F = 30\text{mA}$
Temperature coefficient of $V_F$	$TC_V$	---	-2.8	---	mV/K	$I_F = 30\text{mA}$

Note:

1. Tolerance of Luminous Intensity:  $\pm 11\%$
2. Tolerance of Chromaticity Coordinates is  $\pm 0.01$
3. Tolerance of Forward Voltage:  $\pm 0.1\text{V}$

## Technical Data Sheet

## Hyper Mini Top View LEDs

45-11-BFP-9GABBBA6F-2T8-AM

## Bin Range of Luminous Intensity

Bin Code	Min.	Max.	Unit	Condition
AB	1400	1800	mcd	I <sub>F</sub> = 30mA
BA	1800	2240		
BB	2240	2800		

Note:

Tolerance of Luminous Intensity:  $\pm 11\%$ 

EVERLIGHT

**Technical Data Sheet**

**Hyper Mini Top View LEDs**

**45-11-BFP-9GABBBA6F-2T8-AM**

**Bin Range of Chromaticity Coordinates**

Bin Code	CIE_x	CIE_y	Condition
9G-1	0.1484	0.1600	I <sub>F</sub> =30mA
	0.1499	0.1800	
	0.1605	0.1800	
	0.1592	0.1600	
9G-2	0.1469	0.1400	
	0.1484	0.1600	
	0.1592	0.1600	
	0.1580	0.1400	

Note:

Tolerance of Chromaticity Coordinates: ±0.01

**The C.I.E. 1931 Chromaticity Diagram**

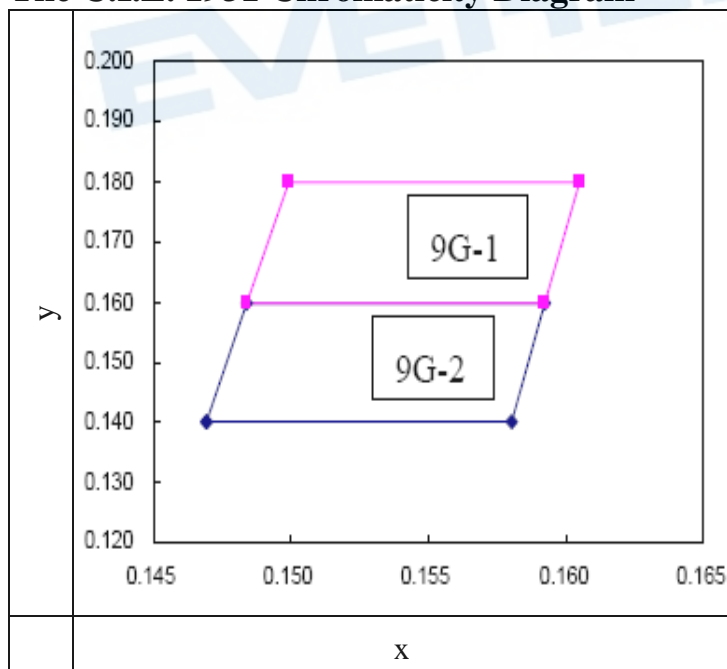

Technical Data Sheet

Hyper Mini Top View LEDs

**45-11-BFP-9GABBBA6F-2T8-AM**

Typical Electro-Optical Characteristics Curves

Typical Curve of Spectral Distribution

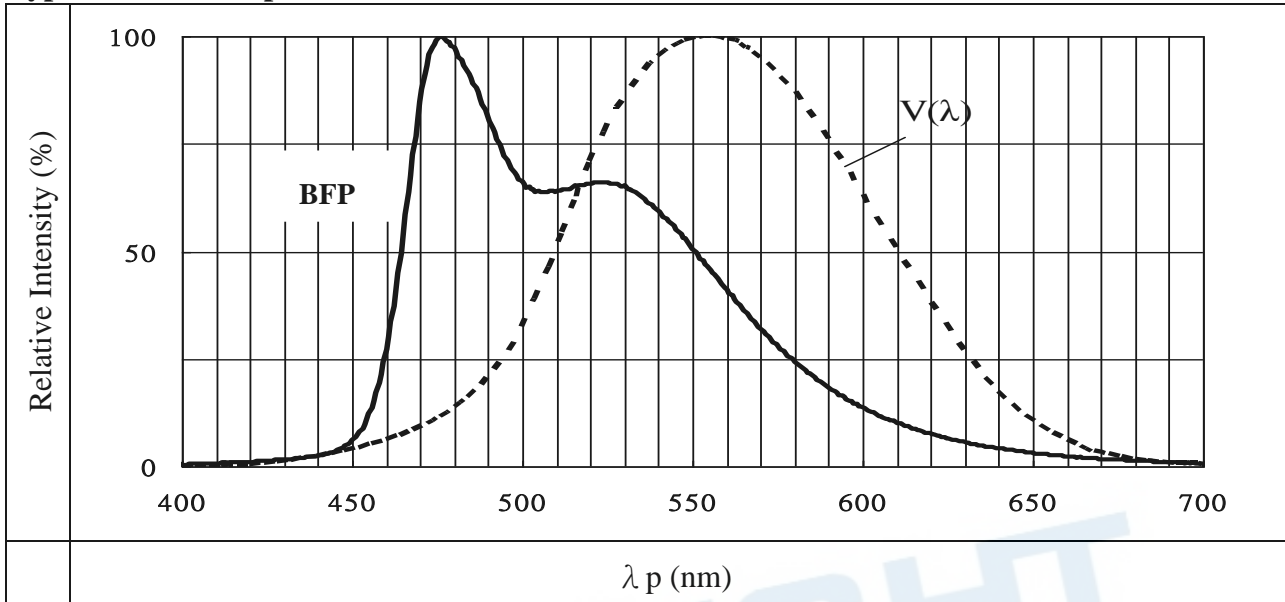

Note:  $V(\lambda)$ =Standard eye response curve;  $I_F = 20\text{mA}$

Diagram Characteristics of Radiation

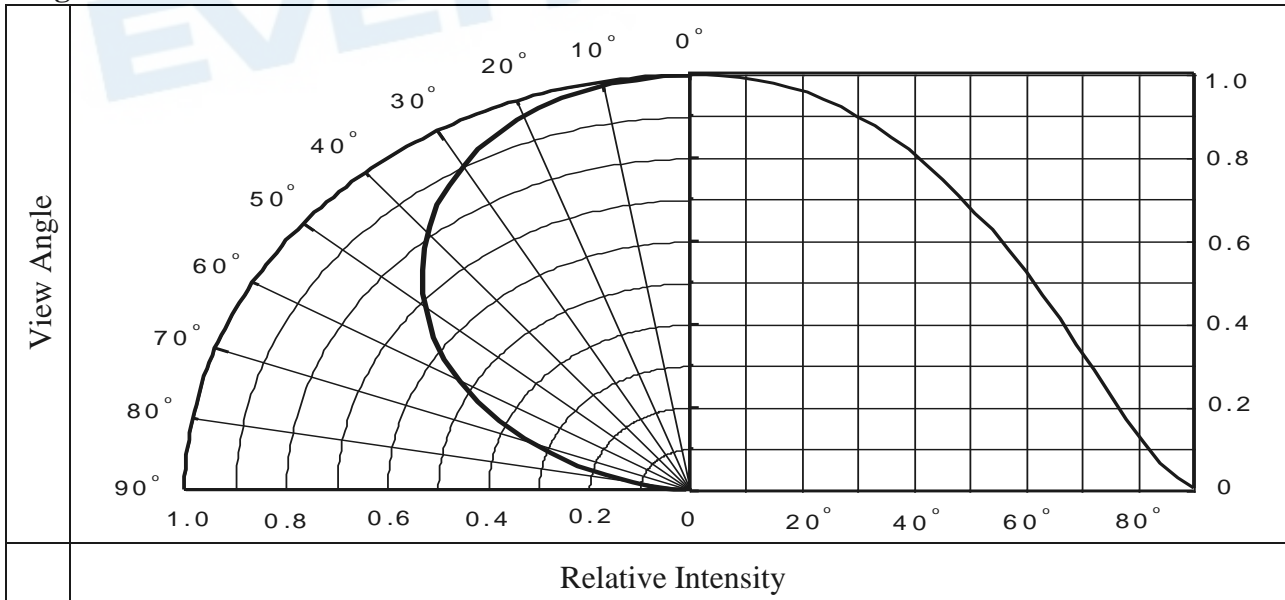

Technical Data Sheet

Hyper Mini Top View LEDs

**45-11-BFP-9GABBBA6F-2T8-AM**

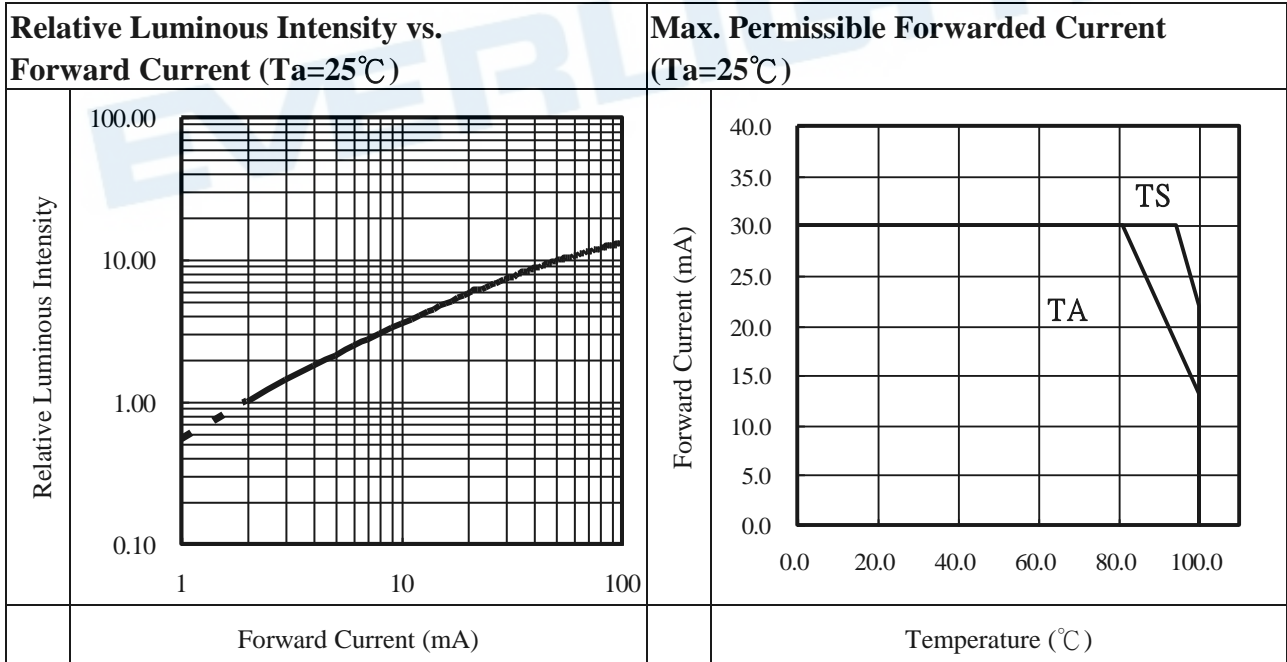
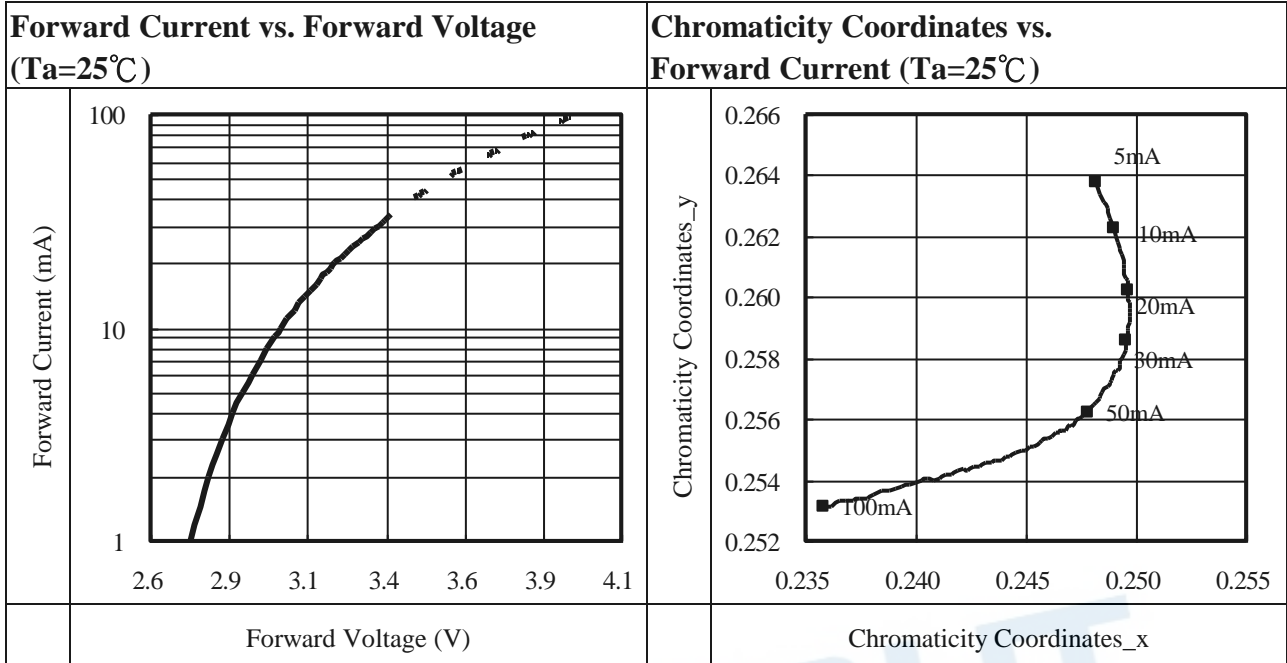

Technical Data Sheet

Hyper Mini Top View LEDs

**45-11-BFP-9GABBBA6F-2T8-AM**

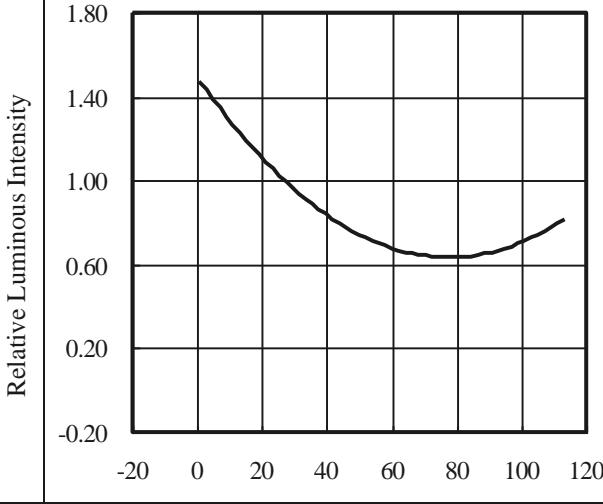
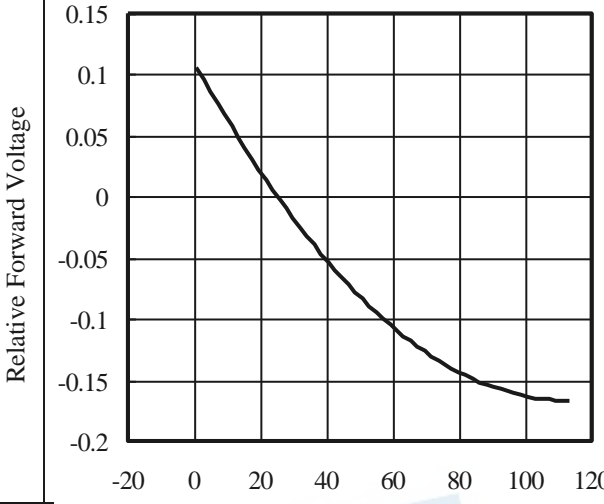
Relative Luminous Intensity vs. Junction Temperature	Relative Forward Voltage vs. Junction Temperature
	
<p>Note: <math>f(T_j) = I_v / I_v(25^\circ\text{C}); I_F = 20\text{mA}</math></p>	<p>Note: <math>\Delta V_F = V_F - V_F(25^\circ\text{C}) = f(T_j); I_F = 20\text{mA}</math></p>



Technical Data Sheet

Hyper Mini Top View LEDs

**45-11-BFP-9GABBBA6F-2T8-AM**

Package Dimension

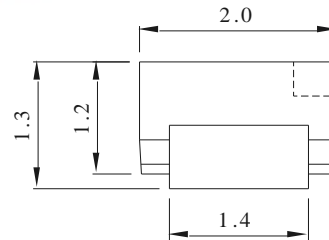
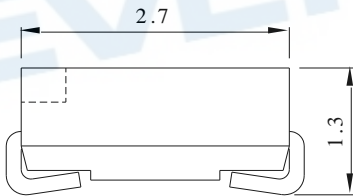
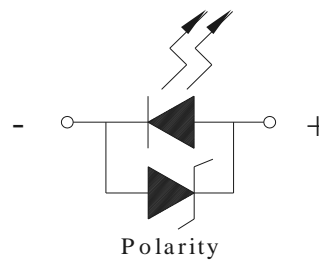
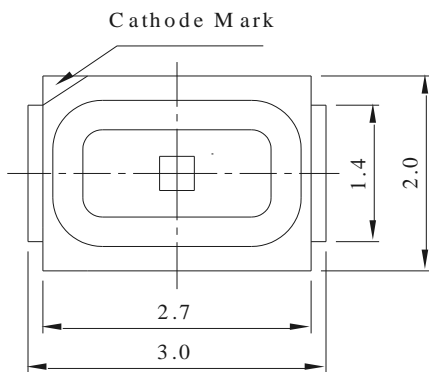

Note: Tolerances unless mentioned  $\pm 0.1\text{mm}$ . Unit = mm

Technical Data Sheet

Hyper Mini Top View LEDs

**45-11-BFP-9GABBBA6F-2T8-AM**

Moisture Resistant Packing Materials

Label Explanation

- CPN: Customer's Product Number
- P/N: Product Number
- QTY: Packing Quantity
- CAT: Luminous Intensity Rank
- HUE: Dom. Wavelength Rank
- REF: Forward Voltage Rank
- LOT No: Lot Number

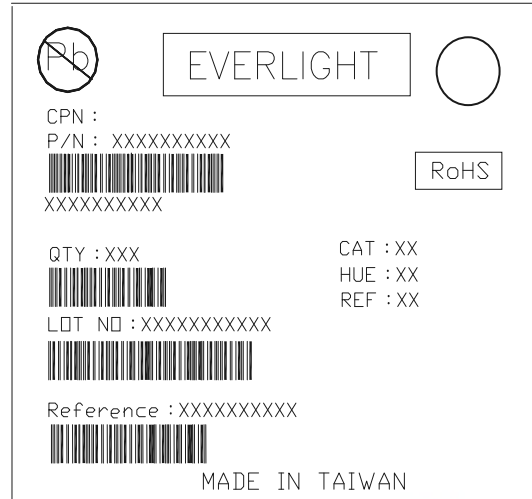

Reel Dimensions

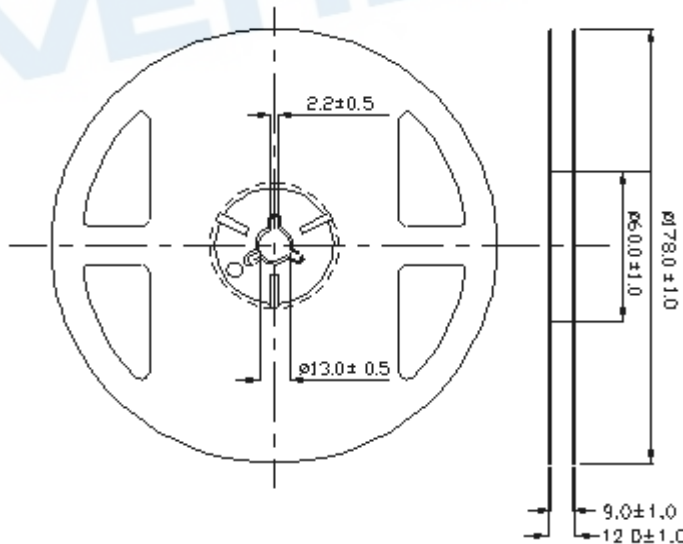

Note: Unit = mm

Technical Data Sheet

Hyper Mini Top View LEDs

**45-11-BFP-9GABBBA6F-2T8-AM**

Carrier Tape Dimensions: Loaded Quantity 2000 pcs Per Reel

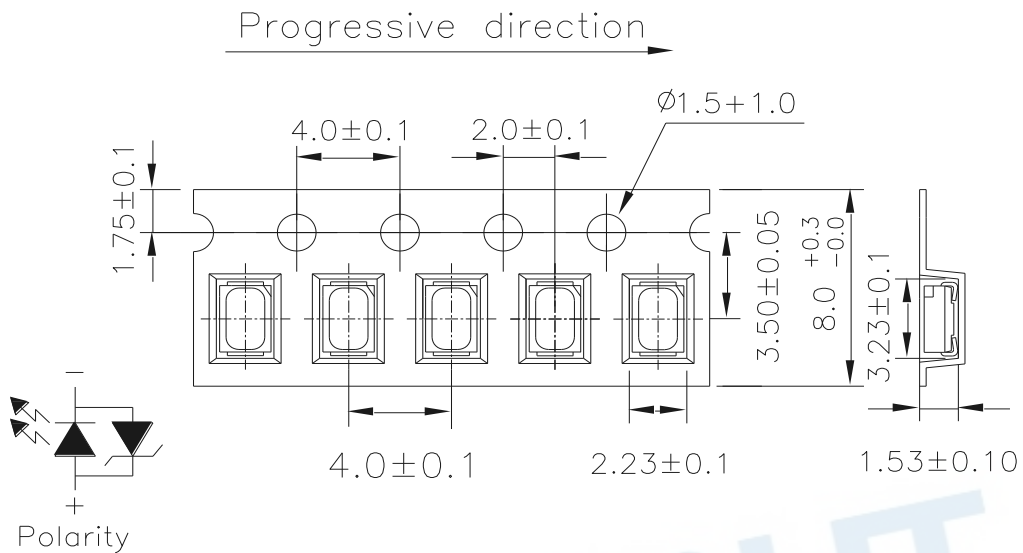

Note: Tolerances unless mentioned  $\pm 0.1$ mm. Unit = mm

Moisture Resistant Packing Process

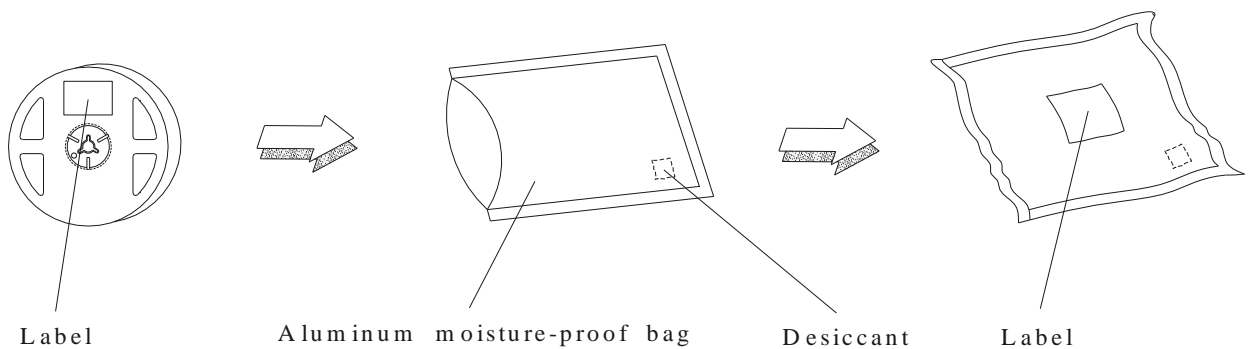

**Technical Data Sheet**

**Hyper Mini Top View LEDs**

**45-11-BFP-9GABBBA6F-2T8-AM**

**Precautions for Use**

**1. Soldering Condition (Reference: IPC/JEDEC J-STD-020D)**

**a. IR reflow**

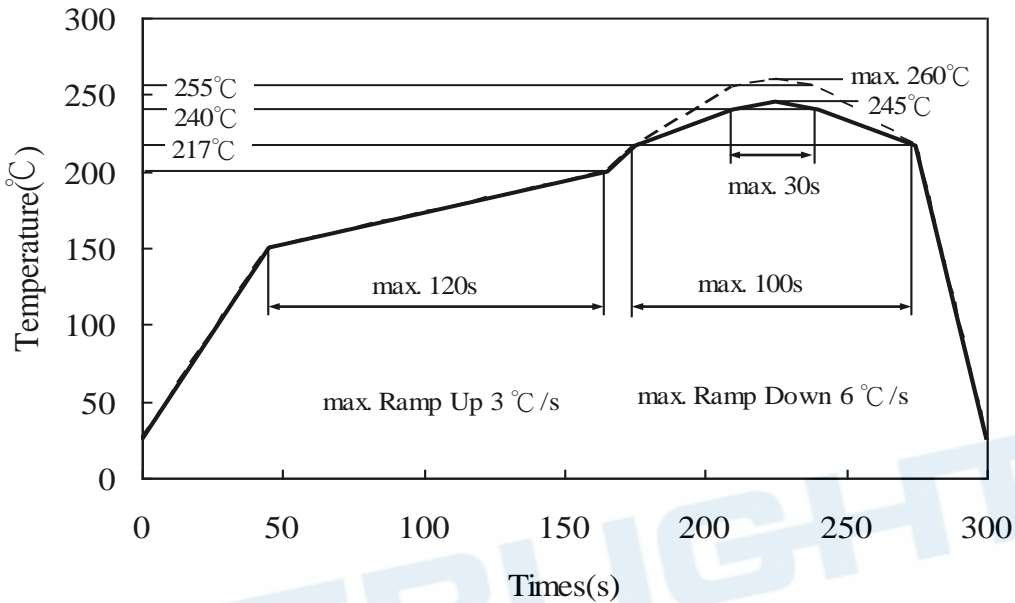

**b. Wave soldering reflow**

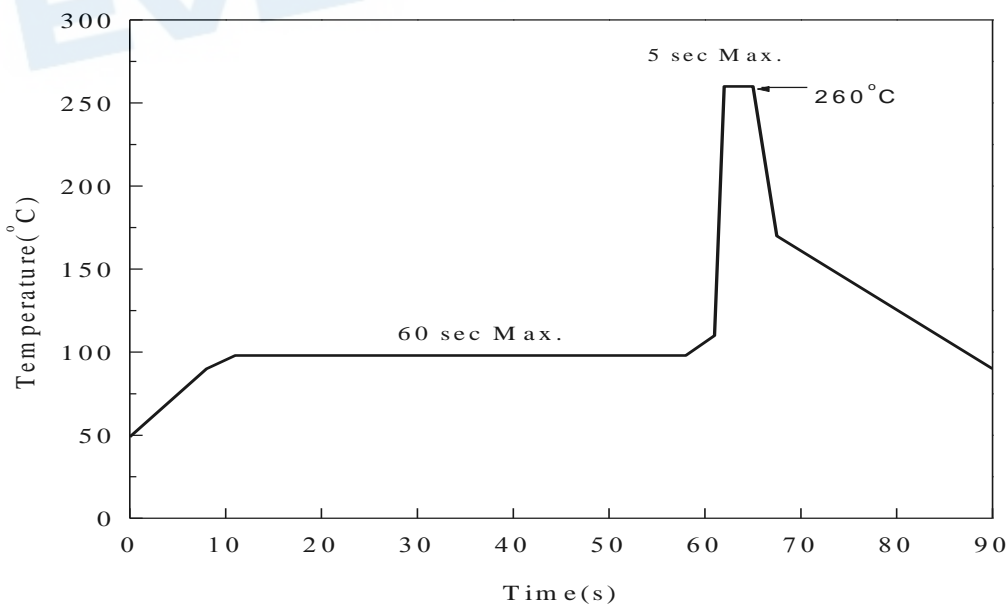

**Technical Data Sheet**

**Hyper Mini Top View LEDs**

**45-11-BFP-9GABBBA6F-2T8-AM**

(B) Recommend soldering pad

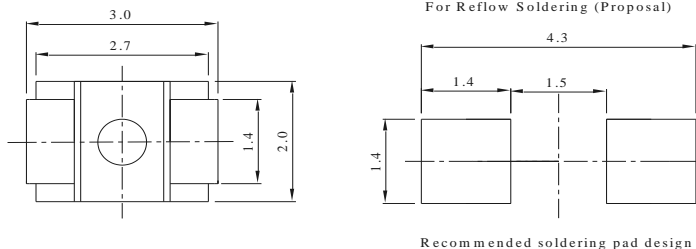

**Note:** Tolerances unless mentioned  $\pm 0.1\text{mm}$ . Unit = mm

**2. Current limiting**

A resistor should be used to limit current spikes that can be caused by voltage fluctuations. Otherwise damage could occur.

**3. Storage**

- 3.1 Moisture proof bag should only be opened immediately prior to usage.
- 3.2 Environment should be less than  $30^{\circ}\text{C}$  and 60% RH when moisture proof bag is opened.
- 3.3 After opening the package MSL Conditions stated on page 1 of this spec should not be exceeded.
- 3.4 If the moisture sensitivity card indicates higher than acceptable moisture, the component should be baked at min.  $60\text{deg} \pm 5\text{deg}$  for 24 hours.

**4. Iron Soldering**

Hand soldering is not recommended for regular production. These guidelines are for rework only. Soldering iron tip should contact each terminal no more than 3 sec at  $350^{\circ}\text{C}$ , using soldering iron with nominal power less than 25W. Allow min. 2 sec. between soldering intervals.

**5. Usage**

Do not exceed the values given in this specification.

**Application Restrictions**

High reliability applications such as military/aerospace, automotive safety/security systems, and medical equipment may require different product. If you have any concerns, please contact Everlight before using this product in your application. This specification guarantees the quality and performance of the product as an individual component. Do not use this product beyond the specification described in this document.



Technical Data Sheet

Hyper Mini Top View LEDs

45-11-BFP-9GABBBA6F-2T8-AM

Revision History:

Rev.	Modified date	File modified contents
1	2010/5/7	New Spec.(Preliminary)
2	2010/7/9	Change Bin Range of Chromaticity Coordinates

