1.0A LOW DROPOUT PRECISION LINEAR REGULATORS** Lead(Pb)-Free**

General Description:

WT1117A of positive adjustable and fixed regulators is designed to provide 1.0A output with low dropout voltage performance. On-chip trimming adjusts the reference voltage to 1.5%. For usage on working in post regulators or microprocessor power supplies, low voltage operation and fast transient response are required.

WT1117A is available in surface-mount SOT-223 and TO-252 packages.

Features:

- * Adjustable or Fixed Output
- * Output Current of 1.0A
- * Dropout Voltage(Typical) 1.15V @1.0A
- * Line Regulation 0.2% max.
- * Load Regulation 0.4% max.
- * Fast Transient Response
- * Current Limit Protection
- * Thermal Shutdown Protection

Applications:

- * High Efficiency Linear Regulators
- * Post Regulators for Switching Supplies
- * Microprocessor Supply
- * Hard Drive Controllers
- * Battery Chargers
- * Adjustable Power Supply

Ordering Information

Ordering Number	Output Voltage	Package	Shipping
WT1117AN-X	Adj	SOT-223	2,500 Units/Tape&Reel
WT1117AD-X	Adj	TO-252	2,500 Units/Tape&Reel
WT1117AN-15	1.5	SOT-223	2,500 Units/Tape&Reel
WT1117AD-15	1.5	TO-252	2,500 Units/Tape&Reel
WT1117AN-18	1.8	SOT-223	2,500 Units/Tape&Reel
WT1117AD-18	1.8	TO-252	2,500 Units/Tape&Reel
WT1117AN-25	2.5	SOT-223	2,500 Units/Tape&Reel
WT1117AD-25	2.5	TO-252	2,500 Units/Tape&Reel
WT1117AN-285	2.85	SOT-223	2,500 Units/Tape&Reel
WT1117AD-285	2.85	TO-252	2,500 Units/Tape&Reel
WT1117AN-30	3.0	SOT-223	2,500 Units/Tape&Reel
WT1117AD-30	3.0	TO-252	2,500 Units/Tape&Reel
WT1117AN-33	3.3	SOT-223	2,500 Units/Tape&Reel
WT1117AD-33	3.3	TO-252	2,500 Units/Tape&Reel
WT1117AN-50	5.0	SOT-223	2,500 Units/Tape&Reel
WT1117AD-50	5.0	TO-252	2,500 Units/Tape&Reel

Marking Information & PIN Configurations (Top View)

TO-252 (DPAK)

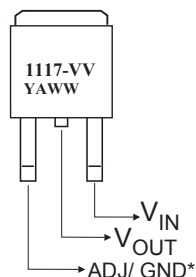

SOT-223

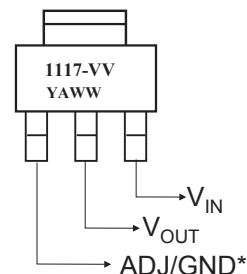

V V/VVV = Output Voltage (50 = 5.0V, 285= 2.85V ,X = ADJ)
 A = Assembly Location
 Y = Year
 W W = Weekly

* On fixed versions Pin 1 = GND,
 on adjustable versions Pin 1 = ADJ
 * Tab = V_{OUT}

Typical Application

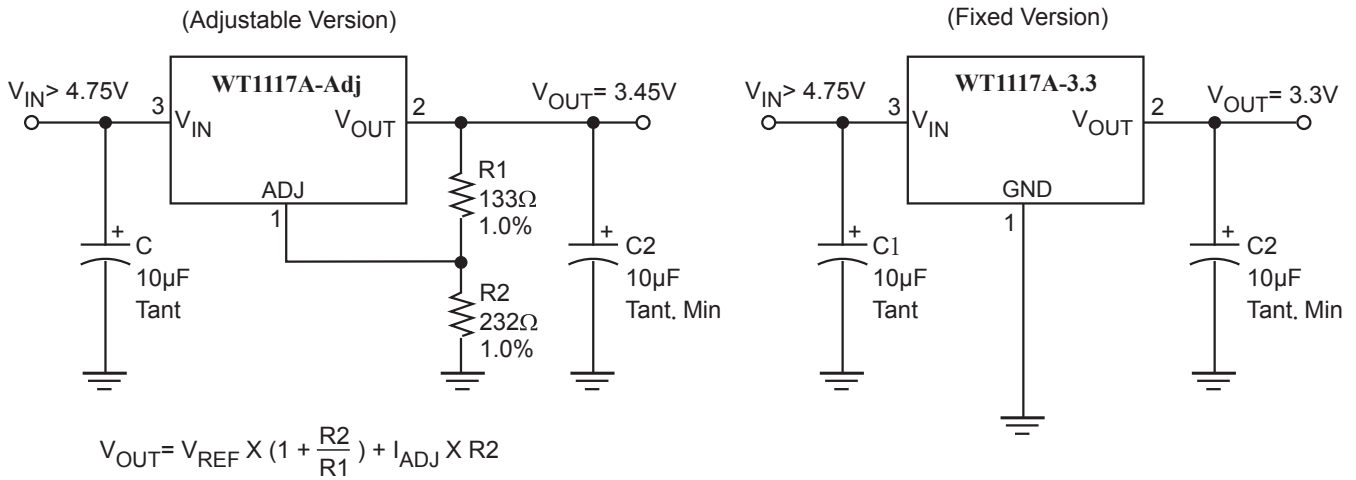

Notes:

1. C1 needed if device is far from filter capacitors
2. C2 minimum value required for stability

Block Diagram

(Fixed Version)

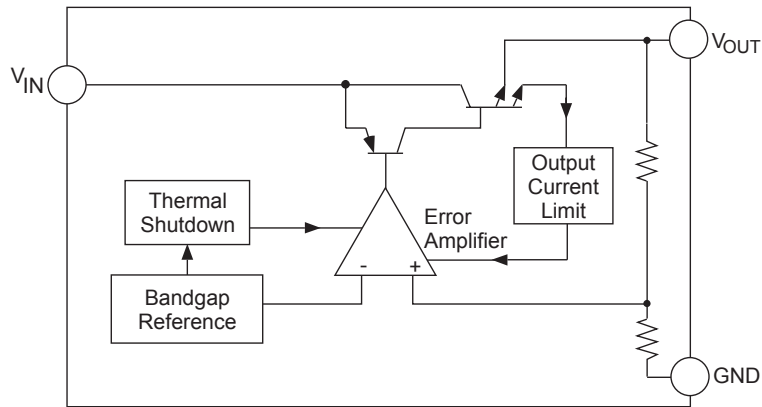

(Adjustable Version)

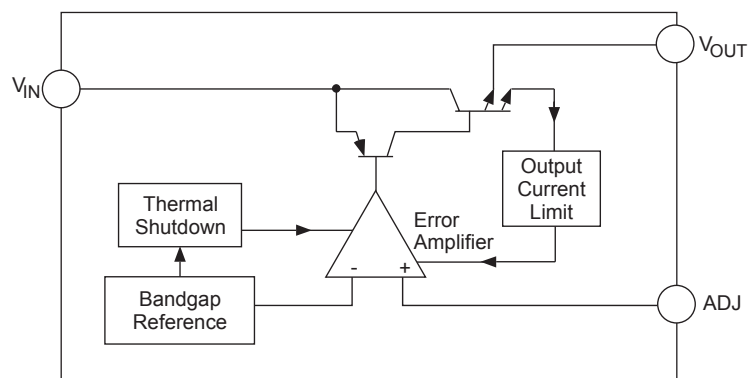

Parameter	Symbol	Value	UNIT
Power Dissipation	P_D	Internally limited	W
Input Voltage	V_{IN}	7.0	V
Lead Temperature(Soldering, 10sec)	T_{LEAD}	300	°C
Operating Junction Temperature Range Control Section Power Transistor	T_J	-40 to 125 -40 to 150	°C
Storage Temperature Range	T_{STG}	-65 to + 150	°C
Thermal Characteristics SOT-223 Thermal Resistance, Junction-to-Case DPAK Thermal Resistance, Junction-to-Case	$R_{\theta JC}$	15 6.0	°C/W

ELECTRICAL CHARACTERISTICS

Typicals and limits appearing in normal type apply for T_j 25°C

Parameter		Symbol	Condition	Min	Typ	Max	Unit
Reference Voltage	WT1117A-Adj	V _{REF}	I _{OUT} =10mA, V _{IN} = 5V 10mA ≤ I _{OUT} ≤ 1.0A, 2.65V ≤ V _{IN} ≤ 7V	1.232 1.225	1.250 1.250	1.268 1.275	V
Output Voltage		-	I _{OUT} =10mA, V _{IN} =V _{OUT} +1.5V V _{IN} =V _{OUT} +1.5V to 7 V 0 ≤ I _{OUT} ≤ 1.0A	-1.5	-	+1.5	%
				-2	-	+2	%
Line Regulation	All	REG _{LINE}	I _{Load} =10mA, (1.5 V +V _{OUT}) ≤ V _{OUT} ≤ 7V	-	0.04	0.20	%
Load Regulation	All	REG _{LOAD}	V _{IN} =V _{OUT} + 1.5V I _{Load} =10mA to 1.0A	-	0.20	0.40	%
Dropout Voltage	All	V _D	I _{OUT} =1.0A	-	1.15	1.3	V
Current Limit	All	I _{CL}	V _{IN} -V _{OUT} =1.5V	1.0	-	-	A
Minimum Load Current	WT1117A-Adj	I _{O MIN}	V _{IN} =5V, V _{adj} =0V	-	2	7	mA
Ground Current	All Fixed Versions	I _Q	V _{IN} =V _{OUT} + 1.5V I _{Load} =10mA to 1.0A	-	7	13	mA
Adjust Pin Current	WT1117A-Adj	I _{ADJ}	I _{Load} =10mA, 2.65V ≤ V _{IN} ≤ 7V	-	35	90	μA
Temp. Coefficient	All		V _{IN} -V _{OUT} =1.5V, I _{Load} =10mA	-	0.005	-	%/°C
Thermal Regulation	All	T _C	T _A =25°C, 30ms pulse	-	0.003	-	%/W
Ripple Rejection (Note 1)	All	R _A	V _{IN} -V _{OUT} =1.5V, I _{Load} =1.0A	60	72	-	dB

Note 1: 120Hz input ripple (C_{ADJ} for ADJ =25μF)

Typical Performance Characteristics

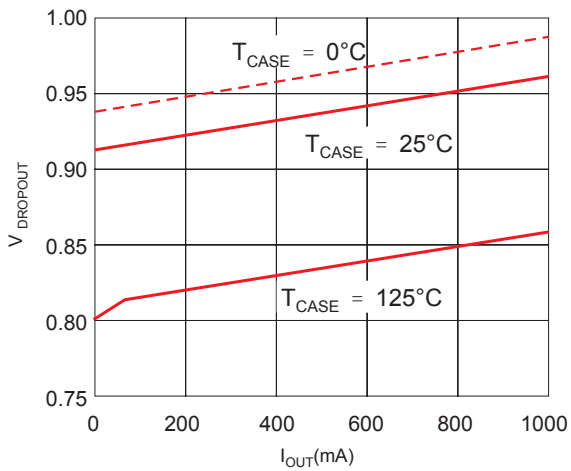

Fig.1 Dropout Voltage vs. Output Current

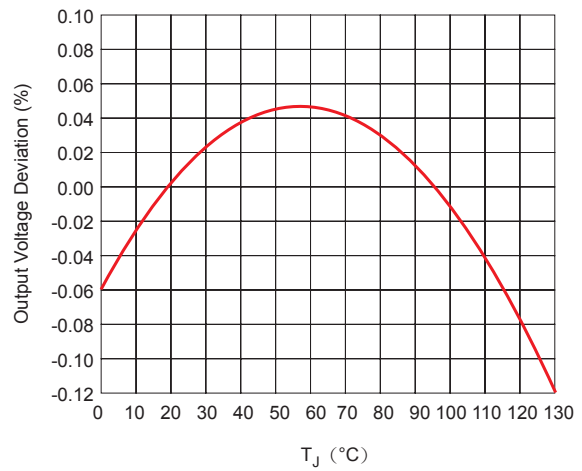

Fig.2 Reference Voltage vs. Temperature

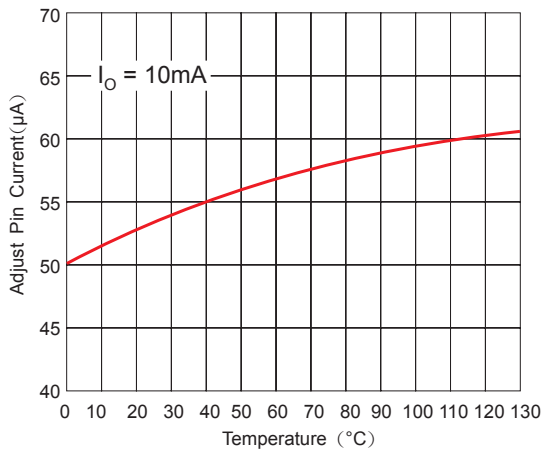

Fig.3 Adjust Pin Current vs. Temperature

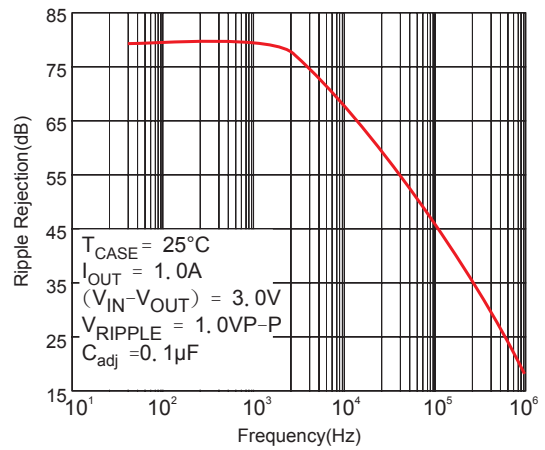

Fig.4 Ripple Rejection vs. Frequency

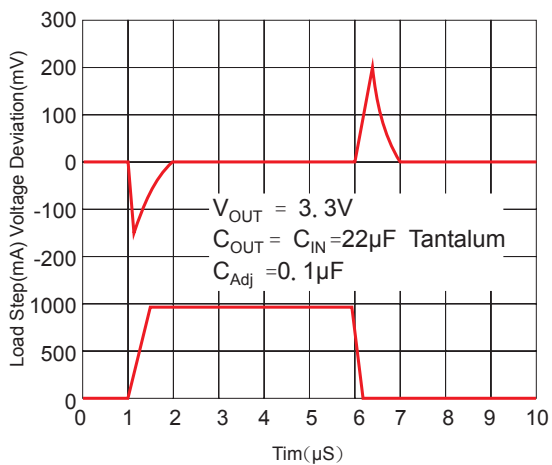

Fig.5 Transient Response

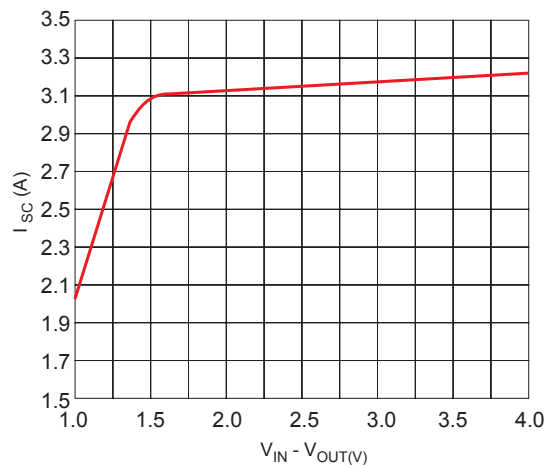

Fig.6 Short Circuit Current vs. $V_{IN} - V_{OUT}$

APPLICATION INFORMATION

WT1117A linear regulators provide fixed and adjustable output voltages at currents up to 1.0A. These regulators are protected against overcurrent conditions and include thermal shutdown protection. The WT1117A's have a composite PNP-NPN output transistor and require an output capacitor for stability. A detailed procedure for selecting this capacitor follows.

Adjustable Operation

The WT1117A has an output voltage range of 1.25 V to 5.5 V. An external resistor divider sets the output voltage as shown in Figure 1. The regulator maintains a fixed 1.25V (typical) reference between the output pin and the adjust pin.

A resistor divider network R1 and R2 causes a fixed current to flow to ground. This current creates a voltage across R2 that adds to the 1.25V across R1 and sets the overall output voltage. The adjust pin current (typically 35µA) also flows through R2 and adds a small error that should be taken into account if precise adjustment of V_{OUT} is necessary.

The output voltage is set according to the formula:

$$V_{OUT} = V_{REF} \times \left(\frac{R1 + R2}{R1} \right) + I_{Adj} \times R2$$

The term $I_{Adj} R2$ represents the error added by the adjust pin current.

R1 is chosen so that the minimum load current is at least 2.0mA R1 and R2 should be the same type e.g. metal film for best tracking over temperature. While not required, a bypass capacitor from the adjust pin to ground will improve ripple rejection and transient response. A 0.1µF tantalum capacitor is recommended for first cut design. Type and value may be varied to obtain optimum performance vs. price.

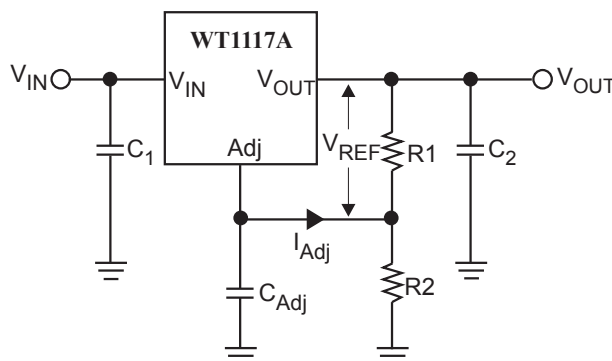

Figure1. Resistor Divider Scheme

Stability Considerations

The output compensation capacitor helps to determine three main characteristics of a linear regulator's performance: start-up delay, load transient response, and loop stability. The capacitor value and type is based on cost, availability, size and temperature constrains, A tantalum or aluminum electrolytic capacitor is preferred, as a film or ceramic capacitor with almost zero ESR can cause instability. An aluminum electrolytic capacitor is the least expensive type. but when the circuit operates at low temperatures, both the value and ESR of the capacitor will vary widely. For optimum performance over the full operating temperature range, a tantalum capacitor is best, A 22µF tantalum capacitor will work fine in most applications, but with high current regulators such as the WT1117A higher capacitance values will improve the transient response and stability. Most applications for the WT1117A's involve large changes in load current, so the output capacitor must supply instantaneous load current. The ESR of the output capacitor causes an immediate drop in output voltage given by: $\Delta V = \Delta I \times ESR$

In microprocessor applications an output capacitor network of several tantalum and ceramic capacitors in parallel is commonly used. This reduces overall ESR and minimizes the instantaneous output voltage drop under transient load conditions. The output capacitor network should be placed as close to the load as possible for the best results. Used with large output capacitance values and the input voltage is instantaneously shorted to ground, damage can occur. In this case, a diode connected as shown above in Figure1.

Protection Diodes

When large external capacitors are used with most linear regulator, it is wise to add protection diodes. If the input voltage of the regulator is shorted, the output capacitor will discharge into the output of the regulator. The discharge current depends on the value of capacitor, output voltage, and rate at which V_{IN} drops.

Figure2 (a),(b) Protection Diode Scheme for Large Output Capacitors

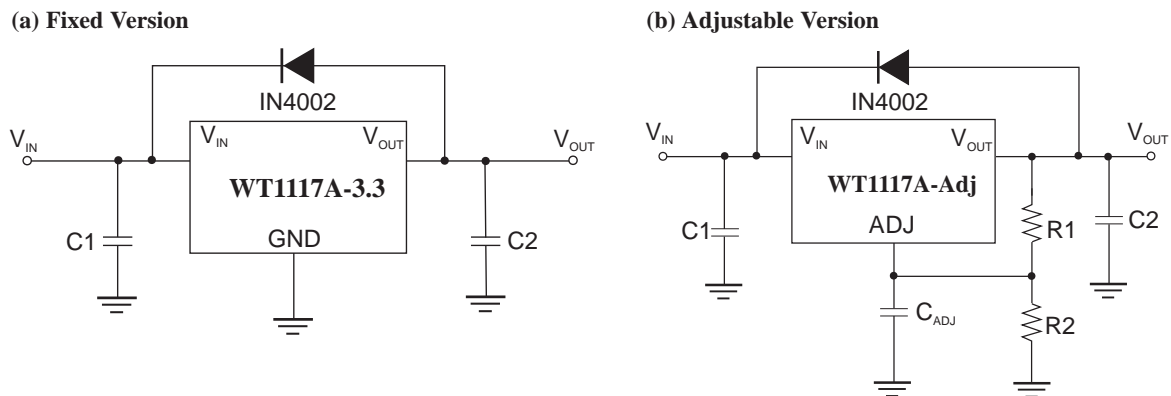

In the WT1117A linear regulators, the discharge path is through a large junction, and protection diodes are normally not needed. However, damage can occur if the regulator is used with large output capacitance values and the input voltage is instantaneously shorted to ground. In this case, a diode connected as shown above in Figure 2.

Output Voltage Sensing

The WT1117A are three terminal regulators. For which, they cannot provide true remote load sensing. Load regulation is limited by the resistance of the conductors connecting the regulator to the load. For best results the WT1117A should be connected as shown in Figure 3.

Figure3 (a),(b) Conductor Parasitic Resistance Effects are Minimized by this Grounding Scheme For Fixed and Adjustable Output Regulators

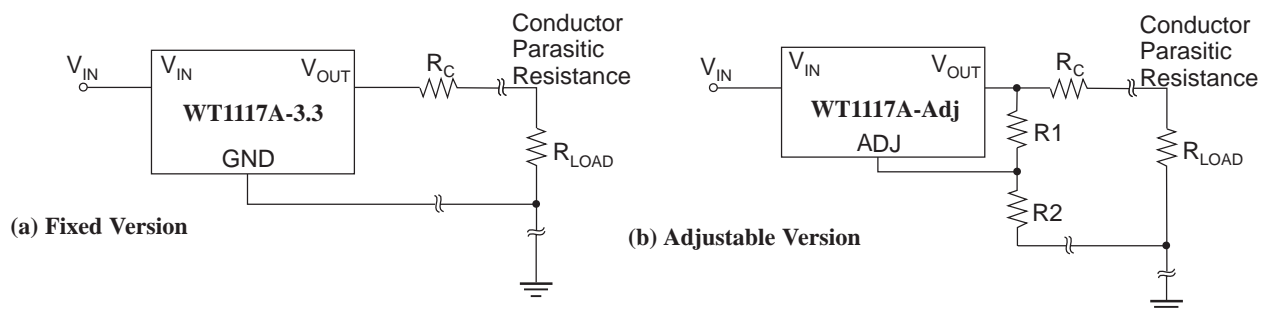

Calculating Power Dissipation and Heat Sink Requirements

The WT1117A precision linear regulators include thermal shutdown and current limit circuitry to protect the devices. However, high power regulators normally operate at high junction temperatures. It is important to calculate the power dissipation and junction temperatures accurately to be sure that you use an adequate heat sink. The case is connected to V_{OUT} on the WT1117A, and electrical isolation may be required for some applications. Thermal compound should always be used with high current regulators like the WT1117A.

The thermal characteristics of an IC depend four factors:

1. Maximum Ambient Temperature $T_A(^{\circ}\text{C})$
2. Power Dissipation P_D (Watts)
3. Maximum Junction Temperature $T_J(^{\circ}\text{C})$
4. Thermal Resistance Junction to ambient $R_{\theta JA}(^{\circ}\text{C}/\text{W})$

The relationship of these four factors is expressed by equation (1):

$$T_J = T_A + P_D \times R_{\theta JA} \dots\dots(1)$$

Maximum ambient temperature and power dissipation are determined by the design while the maximum junction temperature and thermal resistance depend on the manufacturer and the package type.

The maximum power dissipation for a regulator is expressed by equation (2):

$$P_{D(\text{max})} = \{ V_{IN(\text{max})} - V_{OUT(\text{min})} \} I_{OUT(\text{max})} + V_{IN(\text{max})} I_Q \dots\dots(2)$$

where:

- $V_{IN(\text{max})}$ is the maximum input voltage,
- $V_{OUT(\text{min})}$ is the minimum output voltage,
- $I_{OUT(\text{max})}$ is the maximum output current
- I_Q is the maximum quiescent current at $I_{OUT(\text{max})}$.

A heat sink effectively increases the surface area of the package to improve the flow of heat away from the IC into the air. Each material in the heat flow path between the IC and the environment has a thermal resistance. Like series electrical resistances, these resistance are summed to determine $R_{\theta JA}$ the total thermal resistance between the junction and the air. This is expressed by equation (3):

$$R_{\theta JA} = R_{\theta JC} + R_{\theta CS} \times R_{\theta SA} \dots\dots(3)$$

Where all of the following are in $^{\circ}\text{C}/\text{W}$

- $R_{\theta JC}$ is thermal resistance of junction to case,
- $R_{\theta CS}$ is thermal resistance of case to heat sink,
- $R_{\theta SA}$ is thermal resistance of heat sink to ambient air

The value for $R_{\theta JA}$ is calculated using equation (3) and the result can be substituted in equation (1). The value for $R_{\theta JC}$ is $3.5^{\circ}\text{C}/\text{W}$ for a given package type based on an average die size. For a high current regulator such as the WT1117A the majority of the heat is generated in the power transistor section.

TO-252-3 PACKAGE OUTLINE DIMENSIONS

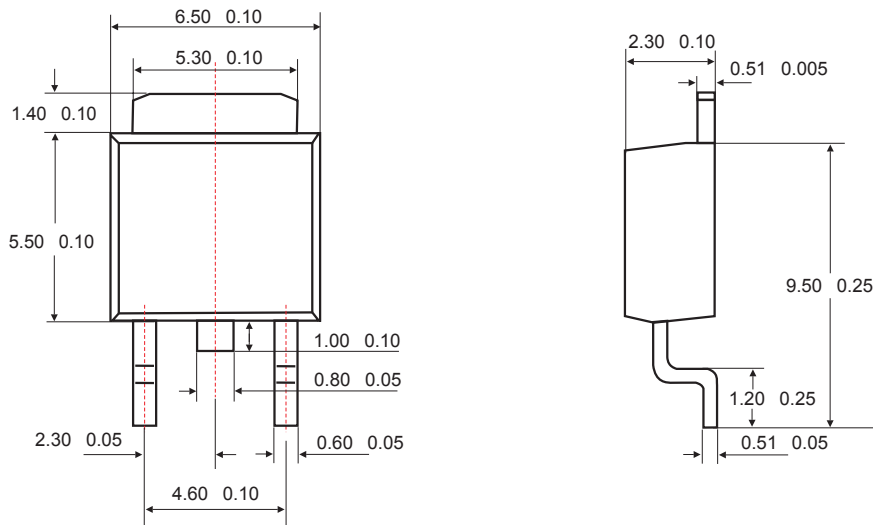

Unit: mm

SOT-223 PACKAGE OUTLINE DIMENSIONS

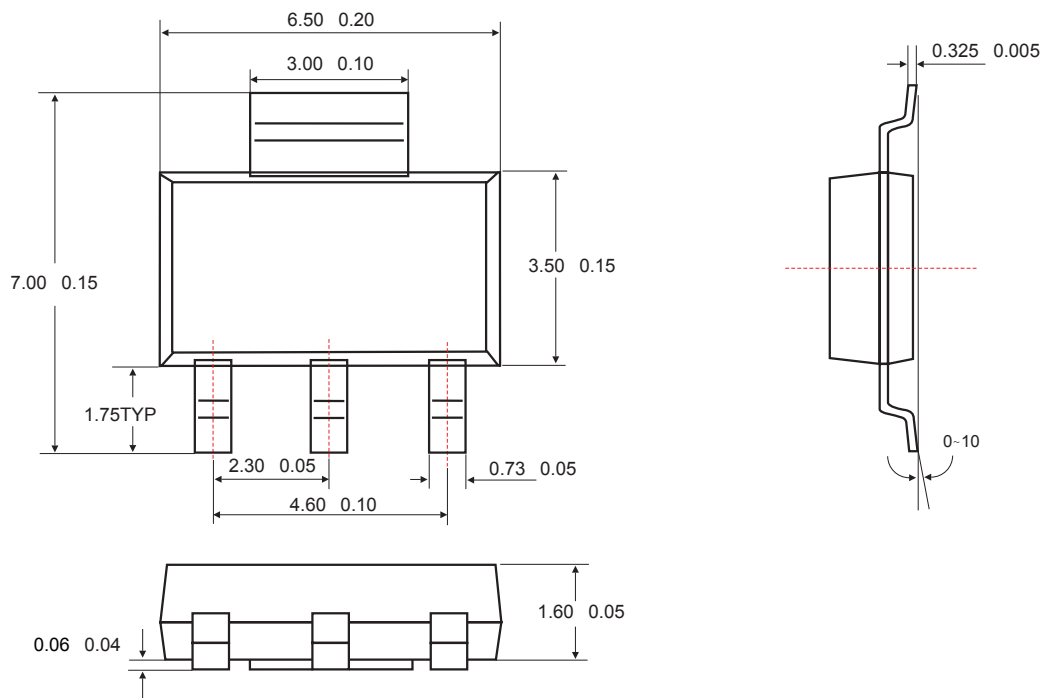

Unit: mm

ORDERING NUMBER

WT1117 A X - XX

