



HIGH SPEED QUAD DIGITAL ISOLATORS

 Check for Samples: [ISO7240CF](#), [ISO7240C](#), [ISO7240M](#), [ISO7241C](#), [ISO7241M](#), [ISO7242C](#), [ISO7242M](#)

FEATURES

- Selectable Failsafe Output (ISO7240CF)
- 25 and 150-Mbps Signaling Rate Options
 - Low Channel-to-Channel Output Skew; 1 ns Max
 - Low Pulse-Width Distortion (PWD); 2 ns Max
 - Low Jitter Content; 1 ns Typ at 150 Mbps
- Typical 25-Year Life at Rated Working Voltage (see application note [SLLA197](#) and [Figure 17](#))
- 4000-V_{peak} V_{IOTM}, 560-V_{peak} V_{IORM} per IEC 60747-5-2 (VDE 0884, Rev 2)
- UL 1577, IEC 61010-1, IEC 60950-1 and CSA Approved
- 4 kV ESD Protection
- Operates With 2.8-V (ISO7241C), 3.3-V or 5-V Supplies
- High Electromagnetic Immunity (see application report [SLLA181](#))
- –40°C to 125°C Operating Range

APPLICATIONS

- Industrial Fieldbus
- Computer Peripheral Interface
- Servo Control Interface
- Data Acquisition

DESCRIPTION

The ISO7240, ISO7241 and ISO7242 are quad-channel digital isolators with multiple channel configurations and output enable functions. These devices have logic input and output buffers separated by TI's silicon dioxide (SiO₂) isolation barrier. Used in conjunction with isolated power supplies, these devices block high voltage, isolate grounds, and prevent noise currents from entering the local ground and interfering with or damaging sensitive circuitry.

The ISO7240 has all four channels in the same direction while the ISO7241 has three channels the same direction and one channel in opposition. The ISO7242 has two channels in each direction.

The C option devices have TTL input thresholds and a noise-filter at the input that prevents transient pulses from being passed to the output of the device. The M option devices have CMOS V_{cc}/2 input thresholds and do not have the input noise-filter or the additional propagation delay.

The ISO7240CF has an input disable function on pin 7, and a selectable high or low failsafe-output function with the CTRL pin (pin 10). The failsafe-output is a logic high when a logic-high is placed on the CTRL pin or it is left unconnected. If a logic-low signal is applied to the CTRL pin, the failsafe-output becomes a logic-low output state. The ISO7240CF input disable function prevents data from being passed across the isolation barrier to the output. When the inputs are disabled, the outputs are set by the CTRL pin.

These devices may be powered from 2.8-V (ISO7241C only), 3.3-V or 5-V supplies on either side in any combination. Note that the signal input pins are 5-V tolerant regardless of the voltage supply level being used.

These devices are characterized for operation over the ambient temperature range of –40°C to 125°C.

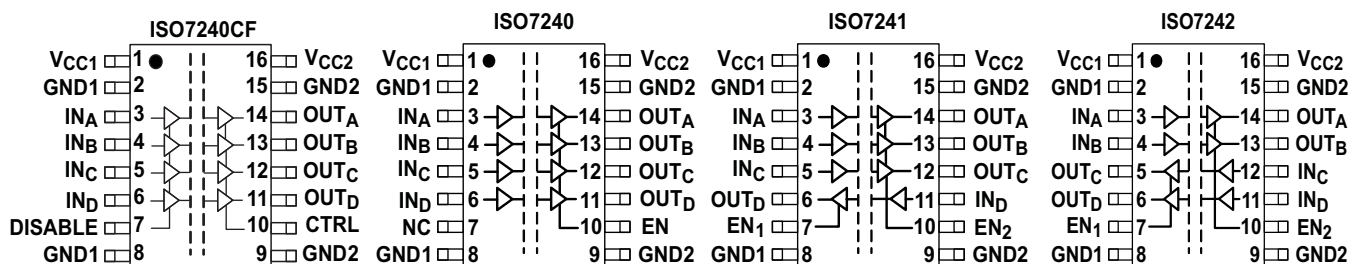

Please be aware that an important notice concerning availability, standard warranty, and use in critical applications of Texas Instruments semiconductor products and disclaimers thereto appears at the end of this data sheet.



These devices have limited built-in ESD protection. The leads should be shorted together or the device placed in conductive foam during storage or handling to prevent electrostatic damage to the MOS gates.

Table 1. Device Function Table ISO724x ⁽¹⁾

INPUT V _{CC}	OUTPUT V _{CC}	INPUT (IN)	OUTPUT ENABLE (EN)	OUTPUT (OUT)
PU	PU	H	H or Open	H
		L	H or Open	L
		X	L	Z
		Open	H or Open	H
PD	PU	X	H or Open	H
PD	PU	X	L	Z

(1) PU = Powered Up; PD = Powered Down ; X = Irrelevant; H = High Level; L = Low Level

Table 2. ISO7240CF Function Table

V _{CC1}	V _{CC2}	DATA INPUT (IN)	DISABLE INPUT (DISABLE)	FAILSAFE CONTROL INPUT (CTRL)	DATA OUTPUT (OUT)
PU	PU	H	L or Open	X	H
PU	PU	L	L or Open	X	L
X	PU	X	H	H or Open	H
X	PU	X	H	L	L
PD	PU	X	X	H or Open	H
PD	PU	X	X	L	L

AVAILABLE OPTIONS

PRODUCT	SIGNALING RATE	INPUT THRESHOLD	CHANNEL CONFIGURATION	MARKED AS	ORDERING NUMBER ⁽¹⁾	
ISO7240C	25 Mbps	~1.5 V (TTL) (CMOS compatible)	4/0	ISO7240C	ISO7240CDW (rail)	
					ISO7240CDWR (reel)	
ISO7240CF	25 Mbps	~1.5 V (TTL) (CMOS compatible)		ISO7240CF	ISO7240CFDW (rail)	
					ISO7240CFDWR (reel)	
ISO7240M	150 Mbps	V _{cc} /2 (CMOS)		ISO7240M	ISO7240MDW (rail)	
					ISO7240MDWR (reel)	
ISO7241C	25 Mbps	~1.5 V (TTL) (CMOS compatible)	3/1	ISO7241C	ISO7241CDW (rail)	
					ISO7241CDWR (reel)	
ISO7241M	150 Mbps	V _{cc} /2 (CMOS)		ISO7241M	ISO7241MDW (rail)	
					ISO7241MDWR (reel)	
ISO7242C	25 Mbps	~1.5 V (TTL) (CMOS compatible)		2/2	ISO7242C	ISO7242CDW (rail)
						ISO7242CDWR (reel)
ISO7242M	150 Mbps	V _{cc} /2 (CMOS)	ISO7242M		ISO7242MDW (rail)	
					ISO7242MDWR (reel)	

(1) For the most current package and ordering information, see the Package Option Addendum at the end of this document, or see the TI website at www.ti.com.

ABSOLUTE MAXIMUM RATINGS⁽¹⁾

				VALUE	UNIT	
V_{CC}	Supply voltage ⁽²⁾ , V_{CC1} , V_{CC2}			-0.5 to 6	V	
V_I	Voltage at IN, OUT, EN, DISABLE, CTRL			-0.5 to 6	V	
I_O	Output current			±15	mA	
ESD	Electrostatic discharge	Human Body Model	JEDEC Standard 22, Test Method A114-C.01	All pins	±4	kV
		Field-Induced-Charged Device Model	JEDEC Standard 22, Test Method C101		±1	
		Machine Model	ANSI/ESDS5.2-1996		±200	V
T_J	Maximum junction temperature			170	°C	

- (1) Stresses beyond those listed under *absolute maximum ratings* may cause permanent damage to the device. These are stress ratings only and functional operation of the device at these or any other conditions beyond those indicated under *recommended operating conditions* is not implied. Exposure to absolute-maximum-rated conditions for extended periods may affect device reliability.
- (2) All voltage values are with respect to network ground terminal and are peak voltage values.

RECOMMENDED OPERATING CONDITIONS

		MIN	TYP	MAX	UNIT	
V_{CC}	Supply voltage ⁽¹⁾ , V_{CC1} , V_{CC2}	ISO7240C/CF, ISO7242C, ISO724xM, ISO7241C	3.15	5.5	V	
			2.8	5.5		
I_{OH}	High-level output current	-4			mA	
I_{OL}	Low-level output current			4	mA	
t_{ui}	Input pulse width	ISO724xC	40		ns	
		ISO724xM	6.67	5		
$1/t_{ui}$	Signaling rate	ISO724xC	0	30 ⁽²⁾	25	Mbps
		ISO724xM	0	200 ⁽²⁾	150	
V_{IH}	High-level input voltage (IN)	ISO724xM	0.7 V_{CC}		V_{CC}	V
V_{IL}	Low-level input voltage (IN)		0		0.3 V_{CC}	V
V_{IH}	High-level input voltage (IN, DISABLE, CTRL, EN)	ISO724xC	2		V_{CC}	V
V_{IL}	Low-level input voltage (IN, DISABLE, CTRL, EN)		0		0.8	V
T_J	Junction temperature			150	°C	
H	External magnetic field-strength immunity per IEC 61000-4-8 and IEC 61000-4-9 certification			1000	A/m	

- (1) For the 5-V operation, V_{CC1} or V_{CC2} is specified from 4.5 V to 5.5 V.
For the 3.3-V operation, V_{CC1} or V_{CC2} is specified from 3.15 V to 3.6 V.
For the 2.8-V operation (ISO7241C-only), V_{CC1} or V_{CC2} is specified at 2.8 V.
- (2) Typical value at room temperature and well-regulated power supply.

IEC 60747-5-2 INSULATION CHARACTERISTICS⁽¹⁾

over recommended operating conditions (unless otherwise noted)

PARAMETER	TEST CONDITIONS	SPECIFICATIONS	UNIT	
V_{IORM}	Maximum working insulation voltage	560	V	
V_{PR}	Input to output test voltage	After Input/Output Safety Test Subgroup 2/3 $V_{PR} = V_{IORM} \times 1.2$, $t = 10$ s, Partial discharge < 5 pC	672	V
		Method a, $V_{PR} = V_{IORM} \times 1.6$, Type and sample test with $t = 10$ s, Partial discharge < 5 pC	896	V
		Method b1, $V_{PR} = V_{IORM} \times 1.875$, 100 % Production test with $t = 1$ s, Partial discharge < 5 pC	1050	V
V_{IOTM}	Transient overvoltage	$t = 60$ s	4000	V
R_S	Insulation resistance	$V_{IO} = 500$ V at T_S	>10 ⁹	Ω
	Pollution degree		2	

- (1) Climatic Classification 40/125/21

ELECTRICAL CHARACTERISTICS: V_{CC1} and V_{CC2} at 5-V⁽¹⁾ OPERATION

over recommended operating conditions (unless otherwise noted)

PARAMETER		TEST CONDITIONS			MIN	TYP	MAX	UNIT
SUPPLY CURRENT								
I_{CC1}	ISO7240C/M	Quiescent	$V_I = V_{CC}$ or 0 V	All channels, no load, EN at 3 V	1	3		mA
		25 Mbps	12.5 MHz Input Clock Signal		7	10.5		
	ISO7241C/M	Quiescent	$V_I = V_{CC}$ or 0 V-	All channels, no load, EN ₁ at 3 V, EN ₂ at 3 V	6.5	11		mA
		25 Mbps	12.5 MHz Input Clock Signal		12	18		
	ISO7242C/M	Quiescent	$V_I = V_{CC}$ or 0 V	All channels, no load, EN ₁ at 3 V, EN ₂ at 3 V	10	16		mA
		25 Mbps	12.5 MHz Input Clock Signal		15	24		
I_{CC2}	ISO7240C/M	Quiescent	$V_I = V_{CC}$ or 0 V-	All channels, no load, EN at 3 V	15	22		mA
		25 Mbps	12.5 MHz Input Clock Signal		17	25		
	ISO7241C/M	Quiescent	$V_I = V_{CC}$ or 0 V	All channels, no load, EN ₁ at 3 V, EN ₂ at 3 V	13	20		mA
		25 Mbps	12.5 MHz Input Clock Signal		18	28		
	ISO7242C/M	Quiescent	$V_I = V_{CC}$ or 0 V	All channels, no load, EN ₁ at 3 V, EN ₂ at 3 V	10	16		mA
		25 Mbps	12.5 MHz Input Clock Signal		15	24		
ELECTRICAL CHARACTERISTICS								
I_{OFF}	Sleep mode output current	EN at 0 V, Single channel			0			μA
V_{OH}	High-level output voltage	$I_{OH} = -4$ mA, See Figure 1			$V_{CC} - 0.8$			V
		$I_{OH} = -20$ μA, See Figure 1			$V_{CC} - 0.1$			
V_{OL}	Low-level output voltage	$I_{OL} = 4$ mA, See Figure 1				0.4		V
		$I_{OL} = 20$ μA, See Figure 1				0.1		
$V_{I(HYS)}$	Input voltage hysteresis				150			mV
I_{IH}	High-level input current	IN from 0 V to V_{CC}				10		μA
I_{IL}	Low-level input current					-10		
C_I	Input capacitance to ground	IN at V_{CC} , $V_I = 0.4 \sin(4E6\pi t)$				2		pF
CMTI	Common-mode transient immunity	$V_I = V_{CC}$ or 0 V, See Figure 5			25	50		kV/μs

(1) For the 5-V operation, V_{CC1} or V_{CC2} is specified from 4.5 V to 5.5 V.

SWITCHING CHARACTERISTICS: V_{CC1} and V_{CC2} at 5-V OPERATION

over recommended operating conditions (unless otherwise noted)

PARAMETER		TEST CONDITIONS	MIN	TYP	MAX	UNIT	
t_{PLH} , t_{PHL}	Propagation delay	See Figure 1	18		42	ns	
PWD	Pulse-width distortion ⁽¹⁾ $ t_{PHL} - t_{PLH} $				2.5		
t_{PLH} , t_{PHL}	Propagation delay		10		23	ns	
PWD	Pulse-width distortion ⁽¹⁾ $ t_{PHL} - t_{PLH} $			1	2		
$t_{sk(pp)}$	Part-to-part skew ⁽²⁾	ISO724xC			8	ns	
		ISO724xM		0	3		
$t_{sk(o)}$	Channel-to-channel output skew ⁽³⁾	ISO724xC			2	ns	
		ISO724xM		0	1		
t_r	Output signal rise time	See Figure 1		2		ns	
t_f	Output signal fall time			2			
t_{PHZ}	Propagation delay, high-level-to-high-impedance output	See Figure 2		15	20	ns	
t_{PZH}	Propagation delay, high-impedance-to-high-level output			15	20		
t_{PLZ}	Propagation delay, low-level-to-high-impedance output			15	20		
t_{PZL}	Propagation delay, high-impedance-to-low-level output			15	20		
t_{fs}	Failsafe output delay time from input power loss	See Figure 3		12		μ s	
t_{wake}	Wake time from input disable	See Figure 4		15		μ s	
$t_{jit(pp)}$	Peak-to-peak eye-pattern jitter	ISO724xM	150 Mbps NRZ data input, Same polarity input on all channels, See Figure 6			1	ns

- (1) Also referred to as pulse skew.
- (2) $t_{sk(pp)}$ is the magnitude of the difference in propagation delay times between any specified terminals of two devices when both devices operate with the same supply voltages, at the same temperature, and have identical packages and test circuits.
- (3) $t_{sk(o)}$ is the skew between specified outputs of a single device with all driving inputs connected together and the outputs switching in the same direction while driving identical specified loads.

ELECTRICAL CHARACTERISTICS: V_{CC1} at 5-V, V_{CC2} at 3.3-V⁽¹⁾ OPERATION

over recommended operating conditions (unless otherwise noted)

PARAMETER		TEST CONDITIONS		MIN	TYP	MAX	UNIT
SUPPLY CURRENT							
I_{CC1}	ISO7240C/M	Quiescent	$V_I = V_{CC}$ or 0 V	All channels, no load, EN at 3 V	1	3	mA
		25 Mbps	12.5 MHz Input Clock Signal		7	10.5	
	ISO7241C/M	Quiescent	$V_I = V_{CC}$ or 0 V	All channels, no load, EN ₁ at 3 V, EN ₂ at 3 V	6.5	11	mA
		25 Mbps	12.5 MHz Input Clock Signal		12	18	
	ISO7242C/M	Quiescent	$V_I = V_{CC}$ or 0 V	All channels, no load, EN ₁ at 3 V, EN ₂ at 3 V	10	16	mA
		25 Mbps	12.5 MHz Input Clock Signal		15	24	
I_{CC2}	ISO7240C/M	Quiescent	$V_I = V_{CC}$ or 0 V	All channels, no load, EN at 3 V	9.5	15	mA
		25 Mbps	12.5 MHz Input Clock Signal		10.5	17	
	ISO7241C/M	Quiescent	$V_I = V_{CC}$ or 0 V	All channels, no load, EN ₁ at 3 V, EN ₂ at 3 V	8	13	mA
		25 Mbps	12.5 MHz Input Clock Signal		11.5	18	
	ISO7242C/M	Quiescent	$V_I = V_{CC}$ or 0 V	All channels, no load, EN ₁ at 3 V, EN ₂ at 3 V	6	10	mA
		25 Mbps	12.5 MHz Input Clock Signal		9	14	
ELECTRICAL CHARACTERISTICS							
I_{OFF}	Sleep mode output current	EN at 0 V, Single channel		0		μ A	
V_{OH}	High-level output voltage	$I_{OH} = -4$ mA, See Figure 1	ISO7240	$V_{CC} - 0.4$		V	
			ISO724x (5-V side)	$V_{CC} - 0.8$			
			$I_{OH} = -20$ μ A, See Figure 1	$V_{CC} - 0.1$			
V_{OL}	Low-level output voltage	$I_{OL} = 4$ mA, See Figure 1	0.4		V		
		$I_{OL} = 20$ μ A, See Figure 1	0.1				
$V_{I(HYS)}$	Input voltage hysteresis			150		mV	
I_{IH}	High-level input current	IN from 0 V to V_{CC}		10		μ A	
I_{IL}	Low-level input current			-10			
C_I	Input capacitance to ground	IN at V_{CC} , $V_I = 0.4 \sin(4E6\pi t)$		2		pF	
CMTI	Common-mode transient immunity	$V_I = V_{CC}$ or 0 V, See Figure 5		25	50	kV/ μ s	

(1) For the 5-V operation, V_{CC1} or V_{CC2} is specified from 4.5 V to 5.5 V.
 For the 3.3-V operation, V_{CC1} or V_{CC2} is specified from 3.15 V to 3.6 V.

SWITCHING CHARACTERISTICS: V_{CC1} at 5-V, V_{CC2} at 3.3-V OPERATION

over recommended operating conditions (unless otherwise noted)

PARAMETER		TEST CONDITIONS	MIN	TYP	MAX	UNIT	
t_{PLH} , t_{PHL}	Propagation delay	See Figure 1	20		50	ns	
PWD	Pulse-width distortion ⁽¹⁾ $ t_{PHL} - t_{PLH} $				3		
t_{PLH} , t_{PHL}	Propagation delay	ISO724xM	12		29	ns	
PWD	Pulse-width distortion ⁽¹⁾ $ t_{PHL} - t_{PLH} $				1		2
$t_{sk(pp)}$	Part-to-part skew ⁽²⁾	ISO724xC			10	ns	
		ISO724xM			0		5
$t_{sk(o)}$	Channel-to-channel output skew ⁽³⁾	ISO724xC			3	ns	
		ISO724xM			0		1
t_r	Output signal rise time	See Figure 1			2	ns	
t_f	Output signal fall time				2		
t_{PHZ}	Propagation delay, high-level-to-high-impedance output	See Figure 2			15	20	ns
t_{PZH}	Propagation delay, high-impedance-to-high-level output				15	20	
t_{PLZ}	Propagation delay, low-level-to-high-impedance output				15	20	
t_{PZL}	Propagation delay, high-impedance-to-low-level output				15	20	
t_{fs}	Failsafe output delay time from input power loss	See Figure 3			18	μ s	
t_{wake}	Wake time from input disable	See Figure 4			15	μ s	
$t_{jit(pp)}$	Peak-to-peak eye-pattern jitter	ISO724xM			1	ns	

(1) Also known as pulse skew

 (2) $t_{sk(pp)}$ is the magnitude of the difference in propagation delay times between any specified terminals of two devices when both devices operate with the same supply voltages, at the same temperature, and have identical packages and test circuits.

 (3) $t_{sk(o)}$ is the skew between specified outputs of a single device with all driving inputs connected together and the outputs switching in the same direction while driving identical specified loads.

ELECTRICAL CHARACTERISTICS: V_{CC1} at 3.3-V, V_{CC2} at 5-V⁽¹⁾ OPERATION

over recommended operating conditions (unless otherwise noted)

PARAMETER		TEST CONDITIONS			MIN	TYP	MAX	UNIT
SUPPLY CURRENT								
I_{CC1}	ISO7240C/M	Quiescent	$V_I = V_{CC}$ or 0 V	All channels, no load, EN at 3 V	0.5	1	mA	
		25 Mbps	12.5 MHz Input Clock Signal		3	5		
	ISO7241C/M	Quiescent	$V_I = V_{CC}$ or 0 V	All channels, no load, EN ₁ at 3 V, EN ₂ at 3 V	4	7	mA	
		25 Mbps	12.5 MHz Input Clock Signal		6.5	11		
	ISO7242C/M	Quiescent	$V_I = V_{CC}$ or 0 V	All channels, no load, EN ₁ at 3 V, EN ₂ at 3 V	6	10	mA	
		25 Mbps	12.5 MHz Input Clock Signal		9	14		
I_{CC2}	ISO7240C/M	Quiescent	$V_I = V_{CC}$ or 0 V	All channels, no load, EN at 3 V	15	22	mA	
		25 Mbps	12.5 MHz Input Clock Signal		17	25		
	ISO7241C/M	Quiescent	$V_I = V_{CC}$ or 0 V	All channels, no load, EN ₁ at 3 V, EN ₂ at 3 V	13	20	mA	
		25 Mbps	12.5 MHz Input Clock Signal		18	28		
	ISO7242C/M	Quiescent	$V_I = V_{CC}$ or 0 V	All channels, no load, EN ₁ at 3 V, EN ₂ at 3 V	10	16	mA	
		25 Mbps	12.5 MHz Input Clock Signal		15	24		
ELECTRICAL CHARACTERISTICS								
I_{OFF}	Sleep mode output current	EN at 0 V, Single channel			0		μ A	
V_{OH}	High-level output voltage	$I_{OH} = -4$ mA, See Figure 1	ISO7240	$V_{CC} - 0.4$	V			
			ISO724x (5-V side)	$V_{CC} - 0.8$				
			$I_{OH} = -20$ μ A, See Figure 1			$V_{CC} - 0.1$		
V_{OL}	Low-level output voltage	$I_{OL} = 4$ mA, See Figure 1			0.4	V		
		$I_{OL} = 20$ μ A, See Figure 1			0.1			
$V_{I(HYS)}$	Input voltage hysteresis				150	mV		
I_{IH}	High-level input current	IN from 0 V to V_{CC}			10		μ A	
I_{IL}	Low-level input current							
C_I	Input capacitance to ground	IN at V_{CC} , $V_I = 0.4 \sin(4E6\pi t)$			2		pF	
CMTI	Common-mode transient immunity	$V_I = V_{CC}$ or 0 V, See Figure 5			25	50	kV/ μ s	

(1) For the 5-V operation, V_{CC1} or V_{CC2} is specified from 4.5 V to 5.5 V.
 For the 3.3-V operation, V_{CC1} or V_{CC2} is specified from 3.15 V to 3.6 V.

SWITCHING CHARACTERISTICS: V_{CC1} at 3.3-V and V_{CC2} at 5-V OPERATION

over recommended operating conditions (unless otherwise noted)

PARAMETER		TEST CONDITIONS	MIN	TYP	MAX	UNIT
t_{PLH} , t_{PHL}	Propagation delay	See Figure 1	22		51	ns
PWD	Pulse-width distortion ⁽¹⁾ $ t_{PHL} - t_{PLH} $				3	
t_{PLH} , t_{PHL}	Propagation delay		12		30	ns
PWD	Pulse-width distortion ⁽¹⁾ $ t_{PHL} - t_{PLH} $			1	2	
$t_{sk(pp)}$	Part-to-part skew ⁽²⁾	ISO724xC			10	ns
		ISO724xM		0	5	
$t_{sk(o)}$	Channel-to-channel output skew ⁽³⁾	ISO724xC			2.5	ns
		ISO724xM		0	1	
t_r	Output signal rise time	See Figure 1		2		ns
t_f	Output signal fall time			2		
t_{PHZ}	Propagation delay, high-level-to-high-impedance output	See Figure 2		15	20	ns
t_{PZH}	Propagation delay, high-impedance-to-high-level output			15	20	
t_{PLZ}	Propagation delay, low-level-to-high-impedance output			15	20	
t_{PZL}	Propagation delay, high-impedance-to-low-level output			15	20	
t_{fs}	Failsafe output delay time from input power loss	See Figure 3		12		μ s
t_{wake}	Wake time from input disable	See Figure 4		15		μ s
$t_{jit(pp)}$	Peak-to-peak eye-pattern jitter	ISO724xM	150 Mbps NRZ data input, Same polarity input on all channels, See Figure 6		1	ns

(1) Also known as pulse skew

 (2) $t_{sk(pp)}$ is the magnitude of the difference in propagation delay times between any specified terminals of two devices when both devices operate with the same supply voltages, at the same temperature, and have identical packages and test circuits.

 (3) $t_{sk(o)}$ is the skew between specified outputs of a single device with all driving inputs connected together and the outputs switching in the same direction while driving identical specified loads.

ELECTRICAL CHARACTERISTICS: V_{CC1} and V_{CC2} at 3.3 V⁽¹⁾ OPERATION

over recommended operating conditions (unless otherwise noted)

PARAMETER		TEST CONDITIONS			MIN	TYP	MAX	UNIT
SUPPLY CURRENT								
I_{CC1}	ISO7240C/M	Quiescent	$V_I = V_{CC}$ or 0 V	All channels, no load, EN at 3 V	0.5	1	mA	
		25 Mbps	12.5 MHz Input Clock Signal		3	5		
	ISO7241C/M	Quiescent	$V_I = V_{CC}$ or 0 V	All channels, no load, EN ₁ at 3 V, EN ₂ at 3 V	4	7	mA	
		25 Mbps	12.5 MHz Input Clock Signal		6.5	11		
	ISO7242C/M	Quiescent	$V_I = V_{CC}$ or 0 V	All channels, no load, EN ₁ at 3 V, EN ₂ at 3 V	6	10	mA	
		25 Mbps	12.5 MHz Input Clock Signal		9	14		
I_{CC2}	ISO7240C/M	Quiescent	$V_I = V_{CC}$ or 0 V	All channels, no load, EN at 3 V	9.5	15	mA	
		25 Mbps	12.5 MHz Input Clock Signal		10.5	17		
	ISO7241C/M	Quiescent	$V_I = V_{CC}$ or 0 V	All channels, no load, EN ₁ at 3 V, EN ₂ at 3 V	8	13	mA	
		25 Mbps	12.5 MHz Input Clock Signal		11.5	18		
	ISO7242C/M	Quiescent	$V_I = V_{CC}$ or 0 V	All channels, no load, EN ₁ at 3 V, EN ₂ at 3 V	6	10	mA	
		25 Mbps	12.5 MHz Input Clock Signal		9	14		
ELECTRICAL CHARACTERISTICS								
I_{OFF}	Sleep mode output current	EN at 0 V, single channel			0			μA
V_{OH}	High-level output voltage	$I_{OH} = -4$ mA, See Figure 1			$V_{CC}-0.4$			V
		$I_{OH} = -20$ μA, See Figure 1			$V_{CC}-0.1$			
V_{OL}	Low-level output voltage	$I_{OL} = 4$ mA, See Figure 1					0.4	V
		$I_{OL} = 20$ μA, See Figure 1					0.1	
$V_{I(HYS)}$	Input voltage hysteresis				150			mV
I_{IH}	High-level input current	IN from 0 V or V_{CC}					10	μA
I_{IL}	Low-level input current				-10			
C_I	Input capacitance to ground	IN at V_{CC} , $V_I = 0.4 \sin(4E6\pi t)$			2			pF
CMTI	Common-mode transient immunity	$V_I = V_{CC}$ or 0 V, See Figure 5			25	50		kV/μs

(1) For the 3.3-V operation, V_{CC1} or V_{CC2} is specified from 3.15 V to 3.6 V.

SWITCHING CHARACTERISTICS: V_{CC1} and V_{CC2} at 3.3-V OPERATION

over recommended operating conditions (unless otherwise noted)

PARAMETER		TEST CONDITIONS	MIN	TYP	MAX	UNIT	
t_{PLH} , t_{PHL}	Propagation delay	See Figure 1	25		56	ns	
PWD	Pulse-width distortion $ t_{PHL} - t_{PLH} ^{(1)}$				4		
t_{PLH} , t_{PHL}	Propagation delay	See Figure 1	12		34	ns	
PWD	Pulse-width distortion $ t_{PHL} - t_{PLH} ^{(1)}$				1		2
$t_{sk(pp)}$	Part-to-part skew ⁽²⁾	ISO724xC			10	ns	
		ISO724xM			0		5
$t_{sk(o)}$	Channel-to-channel output skew ⁽³⁾	ISO724xC			3.5	ns	
		ISO724xM			0		1
t_r	Output signal rise time	See Figure 1		2		ns	
t_f	Output signal fall time			2		ns	
t_{PHZ}	Propagation delay, high-level-to-high-impedance output	See Figure 2		15	20	ns	
t_{PZH}	Propagation delay, high-impedance-to-high-level output			15	20		
t_{PLZ}	Propagation delay, low-level-to-high-impedance output			15	20		
t_{PZL}	Propagation delay, high-impedance-to-low-level output			15	20		
t_{fs}	Failsafe output delay time from input power loss	See Figure 3		18		μ s	
t_{wake}	Wake time from input disable	See Figure 4		15		μ s	
$t_{jit(pp)}$	Peak-to-peak eye-pattern jitter	ISO724xM	150 Mbps PRBS NRZ data input, same polarity input on all channels, See Figure 6			1	ns

- (1) Also referred to as pulse skew.
- (2) $t_{sk(pp)}$ is the magnitude of the difference in propagation delay times between any specified terminals of two devices when both devices operate with the same supply voltages, at the same temperature, and have identical packages and test circuits.
- (3) $t_{sk(o)}$ is the skew between specified outputs of a single device with all driving inputs connected together and the outputs switching in the same direction while driving identical specified loads.

ELECTRICAL CHARACTERISTICS: V_{CC1} and V_{CC2} at 2.8 V (ISO7241C only)⁽¹⁾ OPERATION

over recommended operating conditions (unless otherwise noted)

PARAMETER		TEST CONDITIONS		MIN	TYP	MAX	UNIT
SUPPLY CURRENT							
I_{CC1}	ISO7241C	Quiescent	$V_I = V_{CC}$ or 0 V	All channels, no load, EN ₁ at 3 V, EN ₂ at 3 V	3.9	6.8	mA
		25 Mbps	12.5 MHz Input Clock Signal		6.2	10.5	
I_{CC2}	ISO7241C	Quiescent	$V_I = V_{CC}$ or 0 V	All channels, no load, EN ₁ at 3 V, EN ₂ at 3 V	6.9	12	mA
		25 Mbps	12.5 MHz Input Clock Signal		9.4	16	
ELECTRICAL CHARACTERISTICS							
I_{OFF}	Sleep mode output current	EN ₁ at 0 V, single channel		0			μA
V_{OH}	High-level output voltage	$I_{OH} = -4$ mA, See Figure 1		$V_{CC}-0.6$			V
		$I_{OH} = -20$ μA, See Figure 1		$V_{CC}-0.1$			
V_{OL}	Low-level output voltage	$I_{OL} = 4$ mA, See Figure 1				0.6	V
		$I_{OL} = 20$ μA, See Figure 1				0.1	
$V_{I(HYS)}$	Input voltage hysteresis			150			mV
I_{IH}	High-level input current	IN from 0 V or V_{CC}				10	μA
I_{IL}	Low-level input current			-10			
C_I	Input capacitance to ground	IN at V_{CC} , $V_I = 0.4 \sin(4E6\pi t)$				2	pF
CMTI	Common-mode transient immunity	$V_I = V_{CC}$ or 0 V, See Figure 5		10	45		kV/μs

(1) For the 2.8-V operation, V_{CC1} or V_{CC2} is specified at 2.8-V.
 2.8-V operation is only guaranteed for ISO7241C with production screening starting in January 2012. The first two digits of the Lot Trace Code (YMLLLLS) written on top of each device can be used to identify year and month of production respectively.

SWITCHING CHARACTERISTICS: V_{CC1} and V_{CC2} at 2.8-V OPERATION (ISO7241C only)

over recommended operating conditions (unless otherwise noted)

PARAMETER			TEST CONDITIONS	MIN	TYP	MAX	UNIT
t_{PLH} , t_{PHL}	Propagation delay	ISO7241C	See Figure 1	25		70	ns
PWD	Pulse-width distortion $ t_{PHL} - t_{PLH} $ ⁽¹⁾				5		
$t_{sk(pp)}$	Part-to-part skew ⁽²⁾	ISO7241C				12	ns
$t_{sk(o)}$	Channel-to-channel output skew ⁽³⁾	ISO7241C				5	ns
t_r	Output signal rise time		See Figure 1		2		ns
t_f	Output signal fall time				2		ns
t_{PHZ}	Propagation delay, high-level-to-high-impedance output		See Figure 2		15	25	ns
t_{PZH}	Propagation delay, high-impedance-to-high-level output				15	25	
t_{PLZ}	Propagation delay, low-level-to-high-impedance output				15	25	
t_{PZL}	Propagation delay, high-impedance-to-low-level output				15	25	
t_{fs}	Failsafe output delay time from input power loss		See Figure 3		7		μ s
t_{wake}	Wake time from input disable		See Figure 4		12		μ s

- (1) Also referred to as pulse skew.
- (2) $t_{sk(pp)}$ is the magnitude of the difference in propagation delay times between any specified terminals of two devices when both devices operate with the same supply voltages, at the same temperature, and have identical packages and test circuits.
- (3) $t_{sk(o)}$ is the skew between specified outputs of a single device with all driving inputs connected together and the outputs switching in the same direction while driving identical specified loads.

PARAMETER MEASUREMENT INFORMATION

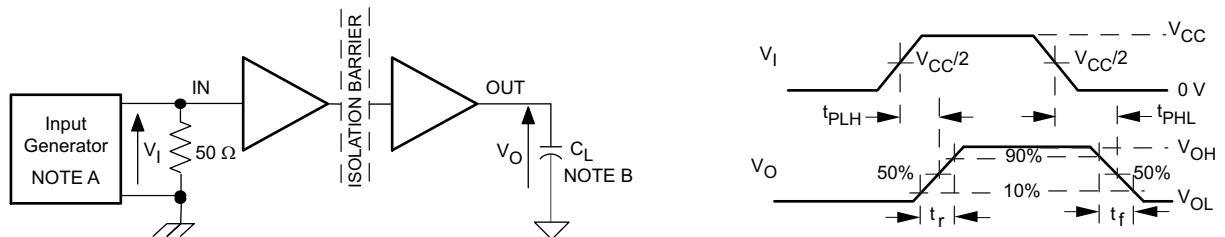

- A. The input pulse is supplied by a generator having the following characteristics: PRR ≤ 50 kHz, 50% duty cycle, $t_r \leq 3$ ns, $t_f \leq 3$ ns, $Z_O = 50 \Omega$.
- B. $C_L = 15$ pF and includes instrumentation and fixture capacitance within $\pm 20\%$.

Figure 1. Switching Characteristic Test Circuit and Voltage Waveforms

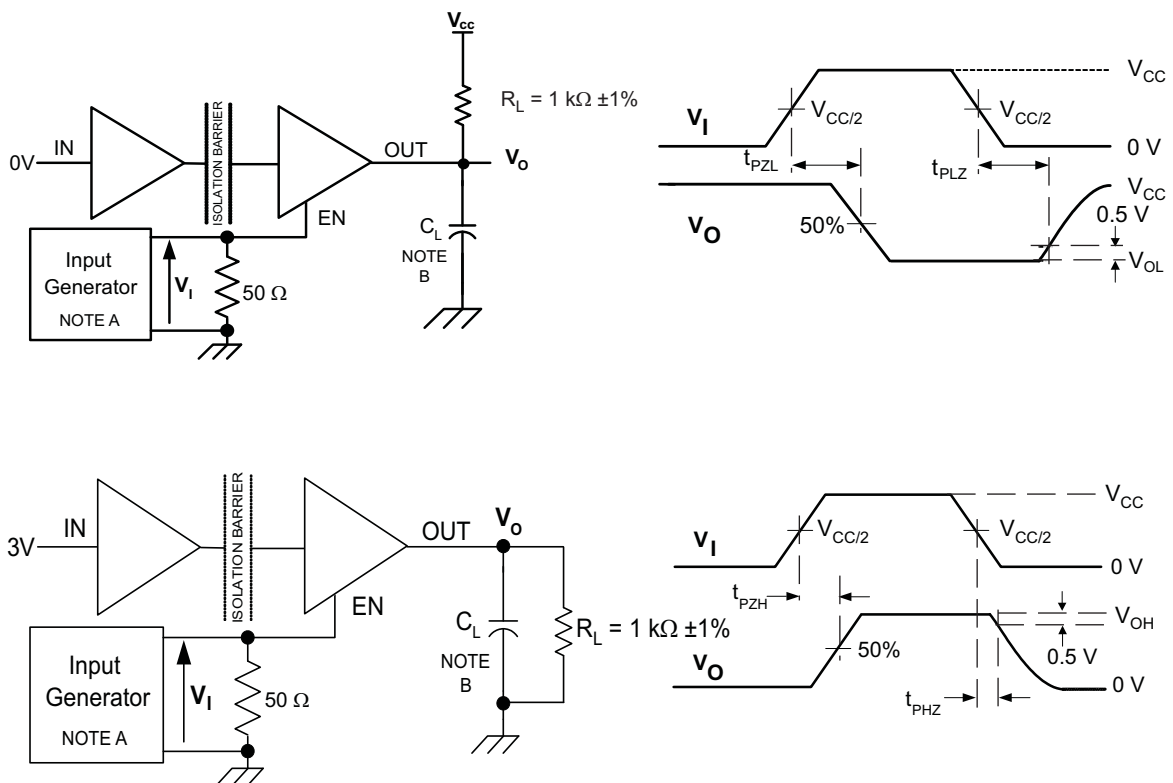

- A. The input pulse is supplied by a generator having the following characteristics: PRR ≤ 50 kHz, 50% duty cycle, $t_r \leq 3$ ns, $t_f \leq 3$ ns, $Z_O = 50 \Omega$.
- B. $C_L = 15$ pF and includes instrumentation and fixture capacitance within $\pm 20\%$.

Figure 2. Enable/Disable Propagation Delay Time Test Circuit and Waveform

PARAMETER MEASUREMENT INFORMATION (continued)

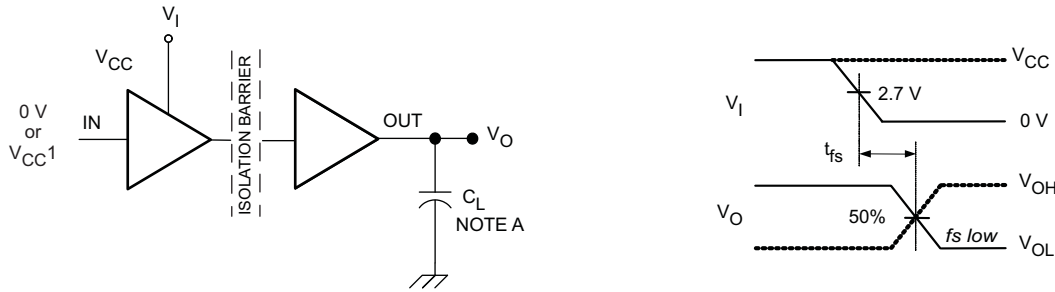

A. $C_L = 15 \text{ pF}$ and includes instrumentation and fixture capacitance within $\pm 20\%$.

Figure 3. Failsafe Delay Time Test Circuit and Voltage Waveforms

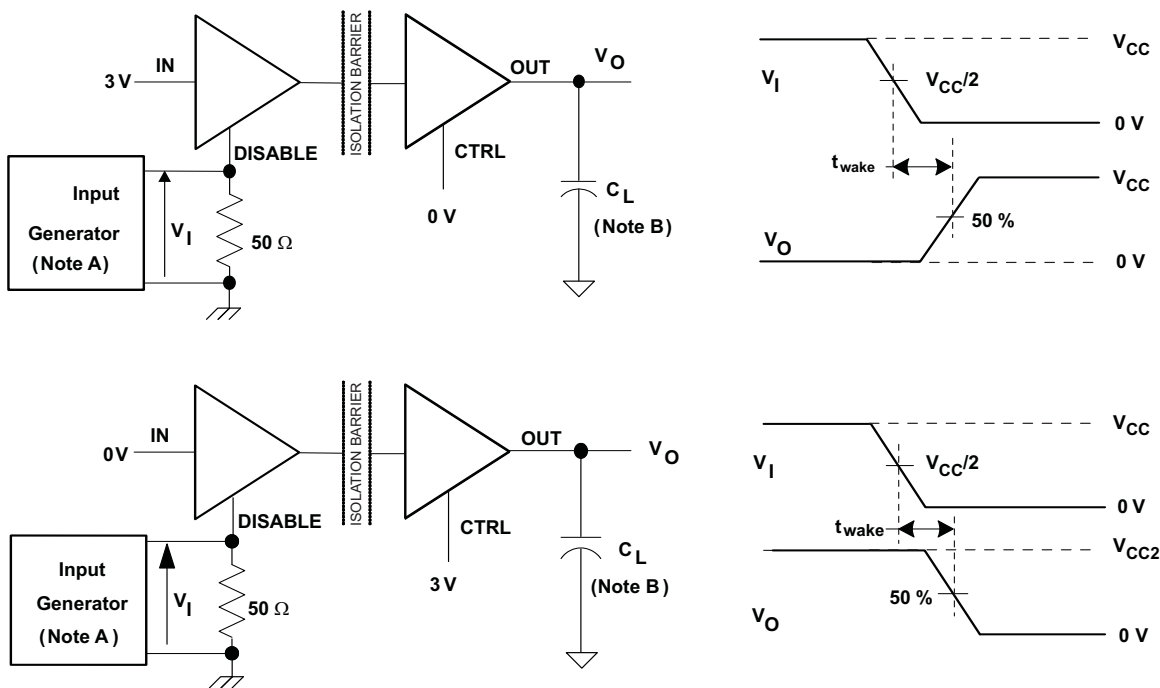

NOTE: Which ever test yields the longest time is used in this data sheet

- A. The input pulse is supplied by a generator having the following characteristics: $\text{PRR} \leq 50 \text{ kHz}$, 50% duty cycle, $t_r \leq 3 \text{ ns}$, $t_f \leq 3 \text{ ns}$, $Z_O = 50 \Omega$.
- B. $C_L = 15 \text{ pF}$ and includes instrumentation and fixture capacitance within $\pm 20\%$.

Figure 4. Wake Time From Input Disable Test Circuit and Voltage Waveforms

PARAMETER MEASUREMENT INFORMATION (continued)

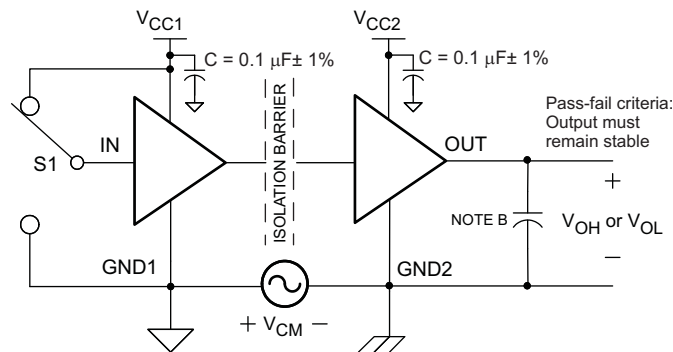

- A. $C_L = 15 \text{ pF}$ and includes instrumentation and fixture capacitance within $\pm 20\%$.
- B. The input pulse is supplied by a generator having the following characteristics: $\text{PRR} \leq 50 \text{ kHz}$, 50% duty cycle, $t_r \leq 3 \text{ ns}$, $t_f \leq 3 \text{ ns}$, $Z_O = 50 \Omega$.

Figure 5. Common-Mode Transient Immunity Test Circuit and Voltage Waveform

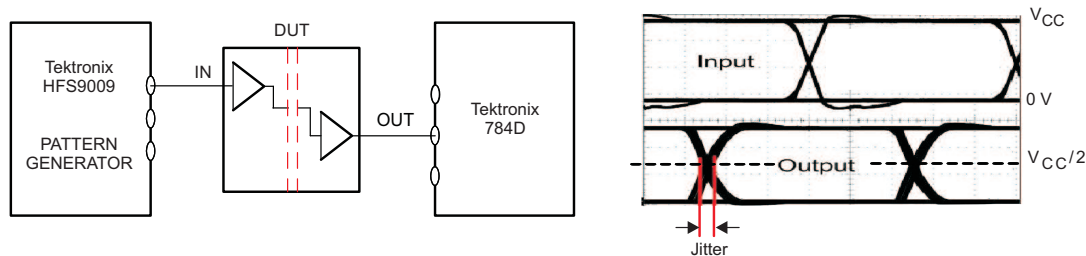

NOTE: PRBS bit pattern run length is $2^{16} - 1$. Transition time is 800 ps. NRZ data input has no more than five consecutive 1s or 0s.

Figure 6. Peak-to-Peak Eye-Pattern Jitter Test Circuit and Voltage Waveform

DEVICE INFORMATION

PACKAGE CHARACTERISTICS

PARAMETER	TEST CONDITIONS	MIN	TYP	MAX	UNIT
L(I01) Minimum air gap (Clearance)	Shortest terminal-to-terminal distance through air	8.34			mm
L(I02) Minimum external tracking (Creepage)	Shortest terminal-to-terminal distance across the package surface	8.1			mm
CTI Tracking resistance (comparative tracking index)	DIN IEC 60112/VDE 0303 Part 1	≥ 400			V
Minimum Internal Gap (Internal Clearance)	Distance through the insulation	0.008			mm
R_{IO} Isolation resistance	Input to output, $V_{IO} = 500 \text{ V}$, all pins on each side of the barrier tied together creating a two-terminal device	$>10^{12}$			Ω
C_{IO} Barrier capacitance Input to output	$V_1 = 0.4 \sin(4E6\pi t)$		2		pF
C_I Input capacitance to ground	$V_1 = 0.4 \sin(4E6\pi t)$		2		pF

IEC 60664-1 RATINGS TABLE

PARAMETER	TEST CONDITIONS	SPECIFICATION
Basic isolation group	Material group	II
Installation classification	Rated mains voltage $\leq 150 \text{ V}_{\text{RMS}}$	I-IV
	Rated mains voltage $\leq 300 \text{ V}_{\text{RMS}}$	I-III

REGULATORY INFORMATION

VDE	CSA	UL
Certified according to IEC 60747-5-2	Approved under CSA Component Acceptance Notice 5A	Recognized under 1577 Component Recognition Program
Basic Insulation Maximum Transient Overvoltage, 4000 V _{PK} Maximum Surge Voltage, 4000 V _{PK} Maximum Working Voltage, 560 V _{PK}	Basic insulation per CSA 60950-1-07 and IEC 60950-1 (2nd Ed), 395 V _{RMS} maximum working voltage, 4000 V _{PK} maximum isolation rating	Single protection, 2500 V _{RMS} ⁽¹⁾
File Number: 40016131	File Number: 220991	File Number: E181974

(1) Production tested ≥ 3000 V_{RMS} for 1 second in accordance with UL 1577.

DEVICE I/O SCHEMATICS

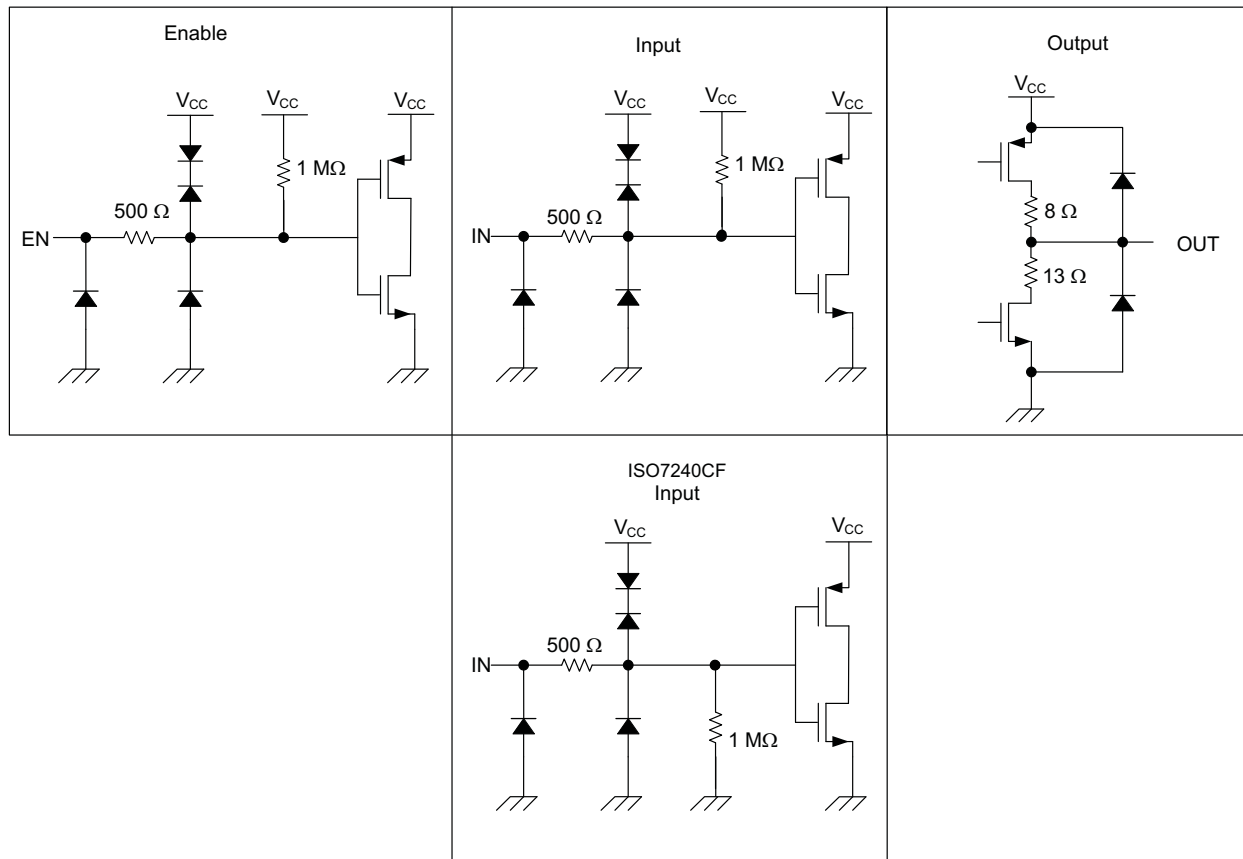

THERMAL CHARACTERISTICS

over recommended operating conditions (unless otherwise noted)

PARAMETER		TEST CONDITIONS	MIN	TYP	MAX	UNIT
θ_{JA}	Junction-to-air	Low-K Thermal Resistance ⁽¹⁾		168		°C/W
		High-K Thermal Resistance		96.1		
θ_{JB}	Junction-to-Board Thermal Resistance			61		°C/W
θ_{JC}	Junction-to-Case Thermal Resistance			48		°C/W
P_D	Device Power Dissipation	$V_{CC1} = V_{CC2} = 5.5\text{ V}$, $T_J = 150^\circ\text{C}$, $C_L = 15\text{ pF}$, Input a 50% duty cycle square wave			220	mW

(1) Tested in accordance with the Low-K or High-K thermal metric definitions of EIA/JESD51-3 for leaded surface mount packages.

TYPICAL CHARACTERISTIC CURVES

ISO7240C/M RMS SUPPLY CURRENT
vs
SIGNALLING RATE

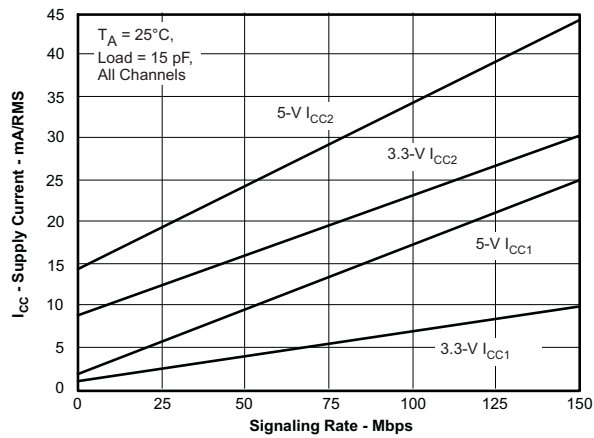

Figure 7.

ISO7241C/M RMS SUPPLY CURRENT
vs
SIGNALLING RATE

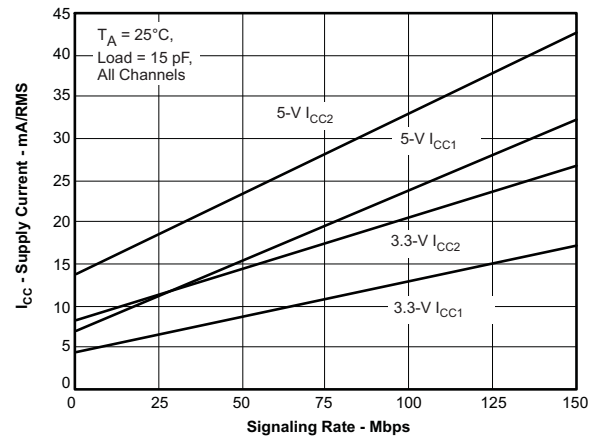

Figure 8.

ISO7242C/M RMS SUPPLY CURRENT
vs
SIGNALLING RATE

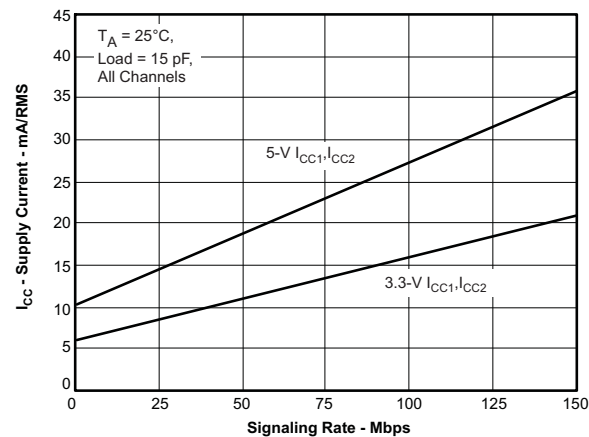

Figure 9.

PROPAGATION DELAY
vs
FREE-AIR TEMPERATURE

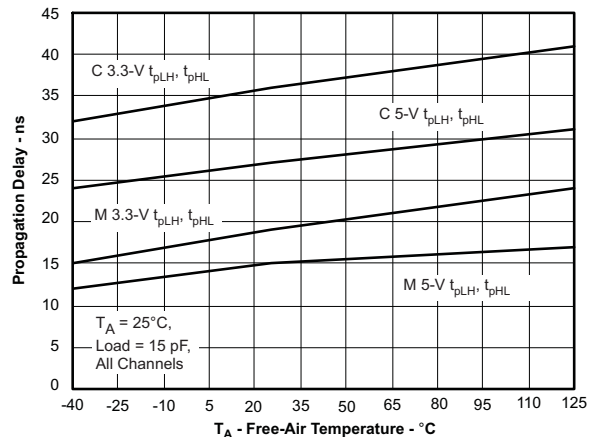

Figure 10.

TYPICAL CHARACTERISTIC CURVES (continued)

**INPUT VOLTAGE THRESHOLD
 vs
 FREE-AIR TEMPERATURE**

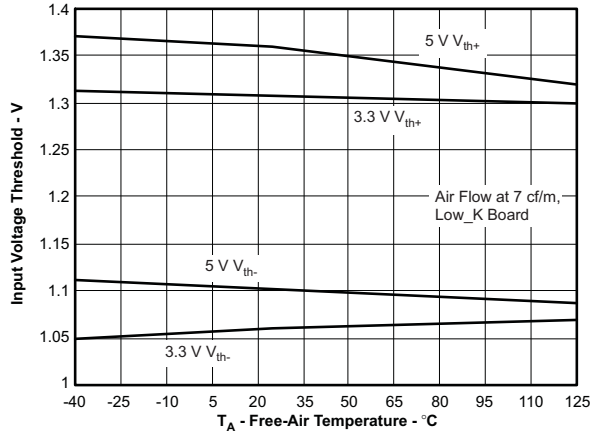

Figure 11.

**V_{CC} UNDERVOLTAGE THRESHOLD
 vs
 FREE-AIR TEMPERATURE**

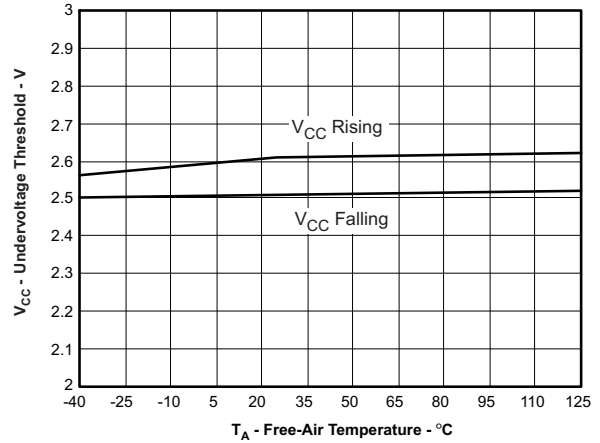

Figure 12.

**HIGH-LEVEL OUTPUT CURRENT
 vs
 HIGH-LEVEL OUTPUT VOLTAGE**

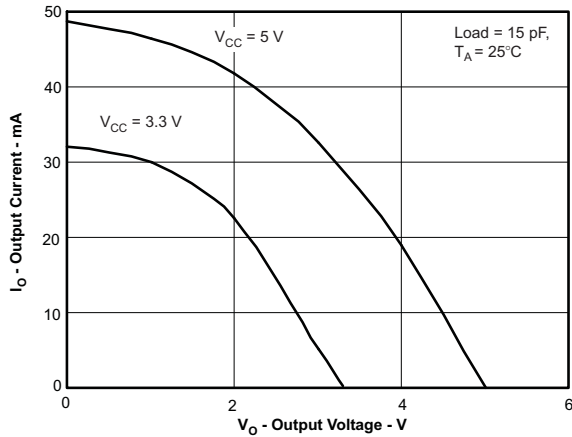

Figure 13.

**LOW-LEVEL OUTPUT CURRENT
 vs
 LOW-LEVEL OUTPUT VOLTAGE**

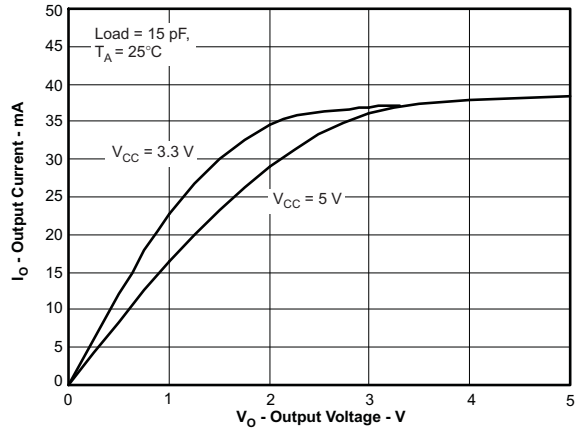

Figure 14.

APPLICATION INFORMATION

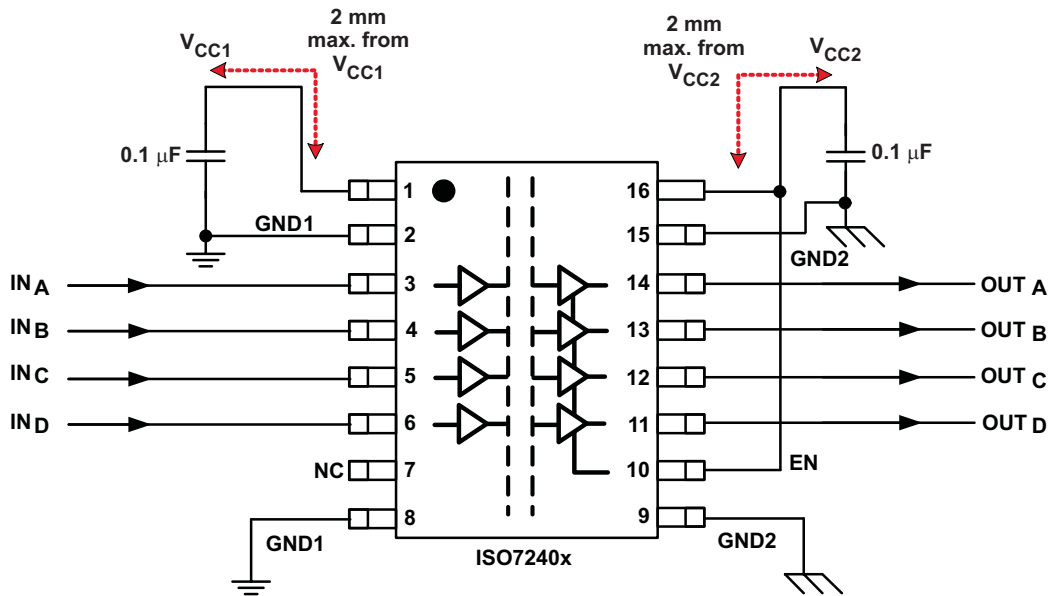

Figure 15. Typical ISO7240x Application Circuit

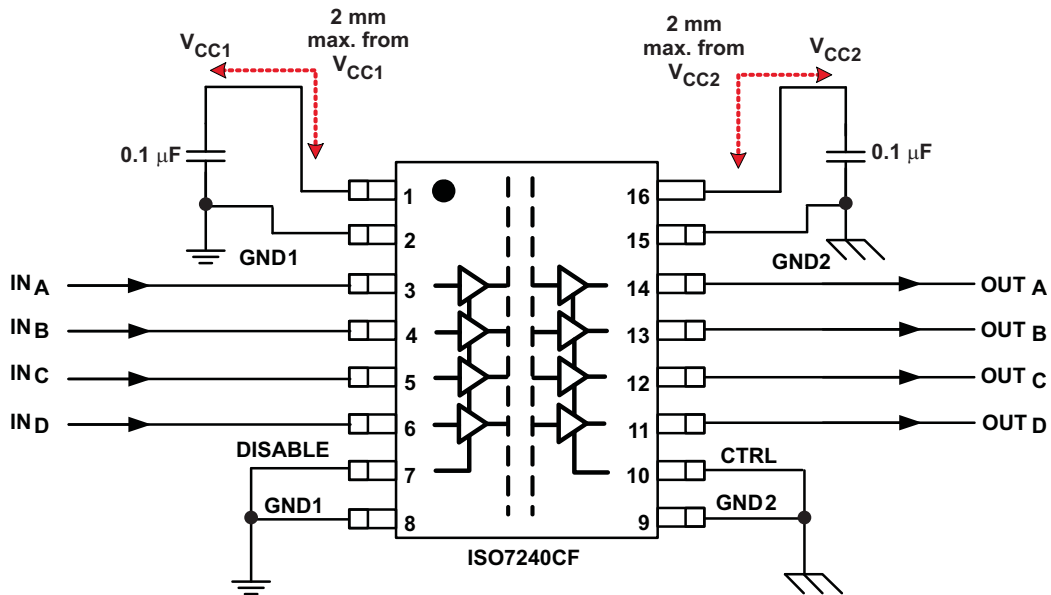

Figure 16. Typical ISO7240CF Failsafe-Low Application Circuit

LIFE EXPECTANCY vs. WORKING VOLTAGE

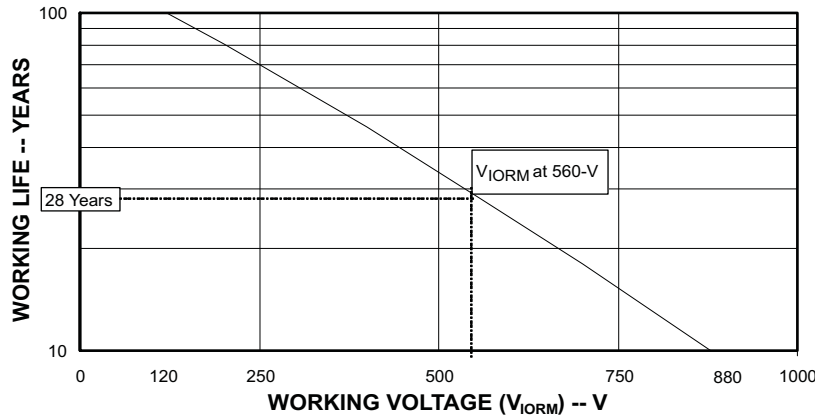

Figure 17. Time-Dependant Dielectric Breakdown Testing Results

REVISION HISTORY

Changes from Original (September 2007) to Revision A	Page
• Deleted Product Preview note	2
• Changed V _{CC} Supply Voltage in the ROC Table From: 3.6 To: 3.45	3
• Changed V _{CC} Supply Voltage in the ROC Table From: 3 To: 3.15	3
• Changed TBDs to actual values.	4
• Changed C ₁ - typ value From: 1 To: 2	4
• Changed Propagation delay max From: 22 To: 23	5
• Changed C ₁ - typ value From: 1 To: 2	6
• Changed Propagation delay max From: 46 To: 50	7
• Changed Propagation delay max From: 28 To: 29	7
• Changed ISO724xA/C max value From: 2.5 To: 3	7
• Changed C ₁ - typ value From: 1 To: 2	8
• Changed Propagation delay max From: 26 To: 30	9
• Changed typ value From: 1 To: 2	10
• Changed Propagation delay max From: 32 To: 34	11
• Changed ISO724xA/C max value From: 3 To: 3.5	11
• Changed C _{IO} - typ value From: 1 To: 2	16
• Changed C ₁ - typ value From: 1 To: 2	16
• Changed the REGULATORY INFORMATION Table	17
• Changed Figure 7 , Figure 8 , and Figure 10 . Added Figure 9	18

Changes from Revision A (December 2007) to Revision B	Page
• Changed V _{CC} Supply Voltage in the ROC Table From: 3.45 To: 3.6	3

Changes from Revision B (August 2008) to Revision C	Page
• Deleted Min = 4.5 V and max = 5.5 V for Supply Voltage of the ROC Table.	3
• Changed V _{CC} Supply Voltage in the ROC Table From: 3.6 To: 5.5	3

Changes from Revision C (April 2008) to Revision D	Page
• Changed Feature Bullet 4000- V_{peak} Isolation	1
• Added $t_{sk(pp)}$ Part-to-part skew	5
• Added $t_{sk(pp)}$ Part-to-part skew	7
• Added $t_{sk(pp)}$ Part-to-part skew	9
• Added $t_{sk(pp)}$ Part-to-part skew	11
• Changed Typical ISO724x Application Circuit Figure 15	20

Changes from Revision D (April 2008) to Revision E	Page
• Added Table Note (1): For the 5-V operation, V_{CC1} or V_{CC2} is specified from 4.5 V to 5.5 V.	3
• Added Table Note (1): For the 5-V operation, V_{CC1} or V_{CC2} is specified from 4.5 V to 5.5 V	6
• Added Table Note (1): For the 5-V operation, V_{CC1} or V_{CC2} is specified from 4.5 V to 5.5 V	8
• Added Table Note (1): For the 5-V operation, V_{CC1} or V_{CC2} is specified from 4.5 V to 5.5 V	10

Changes from Revision E (May 2008) to Revision F	Page
• Changed Title From: QUAD DIGITAL ISOLATORS To: HIGH SPEED QUAD DIGITAL ISOLATORS	1
• Deleted ISO724xA devices. See SLLS905 for the ISO7240A, ISO7241A, and ISO7242A.	1
• Changed Feature Low Jitter Content - From: 1, 25, and 150-Mbps Signaling Rate Options To: 25, and 150-Mbps Signaling Rate Options	1
• Added $t_{sk(pp)}$ footnote.	5
• Added $t_{sk(o)}$ footnote.	5
• Added $t_{sk(pp)}$ footnote.	11
• Added $t_{sk(o)}$ footnote.	11

Changes from Revision F (May 2008) to Revision G	Page
• Changed the PACKAGE CHARACTERISTICS table, line , $L_{(IO1)}$ MIN value from 7.7mm to 8.34mm	16

Changes from Revision G (July 2008) to Revision H	Page
• Added Device number ISO7240CF.	1
• Added Features Bullet: Selectable Failsafe Output (ISO7240CF)	1
• Changed description paragraph 4 text.	1
• Added for device number ISO7240CF.	2
• Changed V_i in the Abs Max Table From: Voltage at IN, OUT, EN To: Voltage at IN, OUT, EN, DISABLE, CTRL	3
• Added t_{wake} , Wake time from input disable	5
• Added t_{wake} , Wake time from input disable	7
• Added t_{wake} , Wake time from input disable	9
• Added t_{wake} , Wake time from input disable	11

Changes from Revision H (October 2008) to Revision I	Page
• Added information to the Features bullet to include CSA and IEC 60950-1 certification	1

Changes from Revision I (December 2008) to Revision J **Page**

- Changed I_{CC1} for Quiescent and 1Mbps From: 10mA To: 11mA 4
 - Changed I_{CC1} for Quiescent and 1Mbps From: 10mA To: 11mA 6
-

Changes from Revision J (April 2009) to Revision K **Page**

- Changed the Input circuit in the DEVICE I/O SCHEMATICS illustration 17
-

Changes from Revision K (December 2009) to Revision L **Page**

- Added the IEC 60747-5-2 INSULATION CHARACTERISTIC table 3
 - Added CTI - Tracking resistance (comparative tracking index to the PACKAGE CHARACTERISTICS table 16
 - Added the IEC 60664-1 RATINGS TABLE 16
-

Changes from Revision L (January 2010) to Revision M **Page**

- Changed [Figure 1](#), [Figure 3](#), and [Figure 4](#) 14
 - Changed the CSA File Number From: 1698195 To: 220991 17
-

Changes from Revision M (January 2011) to Revision N **Page**

- Changed Feature From: 4000- V_{peak} Isolation, 560- V_{peak} V_{IORM} To: 4000- V_{peak} V_{IOTM} , 560- V_{peak} V_{IORM} per IEC 60747-5-2 (VDE 0884, Rev 2) 1
 - Changed Feature From: Operates 3.3-V or 5-V Supplies To: Operates With 2.8-V (ISO7241C), 3.3-V or 5-V Supplies 1
 - Added device options to V_{CC} in the RECOMMENDED OPERATING CONDITIONS table 3
 - Changed Table Note (1) 3
 - Changed I_{CC1} and I_{CC2} test conditions in the V_{CC1} and V_{CC2} at 5-V table 4
 - Changed Table Note (1) 4
 - Changed I_{CC1} and I_{CC2} test conditions in the V_{CC1} at 5-V, V_{CC2} at 3.3-V table 6
 - Changed Table Note (1) 6
 - Changed I_{CC1} and I_{CC2} test conditions in the V_{CC1} at 3.3-V, V_{CC2} at 5-V table 8
 - Changed Table Note (1) 8
 - Changed I_{CC1} and I_{CC2} test conditions in the V_{CC1} and V_{CC2} at 3.3 V table 10
 - Changed Table Note (1) 10
 - Added ELECTRICAL and Switching CHARACTERISTICS tables for V_{CC1} and V_{CC2} at 2.8V (ISO722xC-only) 12
 - Changed the CTI MIN value From: ≥ 175 V To: ≥ 400 V 16
 - Changed the REGULATORY INFORMATION Table 17
 - Changed [Figure 12](#) From V_{CC1} Failsafe Threshold To: V_{CC} Undervoltage Threshold 19
-

PACKAGING INFORMATION

Orderable Device	Status ⁽¹⁾	Package Type	Package Drawing	Pins	Package Qty	Eco Plan ⁽²⁾	Lead/ Ball Finish	MSL Peak Temp ⁽³⁾	Samples (Requires Login)
ISO7240CDW	ACTIVE	SOIC	DW	16	40	Green (RoHS & no Sb/Br)	CU NIPDAU	Level-3-260C-168 HR	
ISO7240CDWG4	ACTIVE	SOIC	DW	16	40	Green (RoHS & no Sb/Br)	CU NIPDAU	Level-3-260C-168 HR	
ISO7240CDWR	ACTIVE	SOIC	DW	16	2000	Green (RoHS & no Sb/Br)	CU NIPDAU	Level-3-260C-168 HR	
ISO7240CDWRG4	ACTIVE	SOIC	DW	16	2000	Green (RoHS & no Sb/Br)	CU NIPDAU	Level-3-260C-168 HR	
ISO7240CFDW	ACTIVE	SOIC	DW	16	40	Green (RoHS & no Sb/Br)	CU NIPDAU	Level-3-260C-168 HR	
ISO7240CFDWG4	ACTIVE	SOIC	DW	16	40	Green (RoHS & no Sb/Br)	CU NIPDAU	Level-3-260C-168 HR	
ISO7240CFDWR	ACTIVE	SOIC	DW	16	2000	Green (RoHS & no Sb/Br)	CU NIPDAU	Level-3-260C-168 HR	
ISO7240CFDWRG4	ACTIVE	SOIC	DW	16	2000	Green (RoHS & no Sb/Br)	CU NIPDAU	Level-3-260C-168 HR	
ISO7240MDW	ACTIVE	SOIC	DW	16	40	Green (RoHS & no Sb/Br)	CU NIPDAU	Level-3-260C-168 HR	
ISO7240MDWG4	ACTIVE	SOIC	DW	16	40	Green (RoHS & no Sb/Br)	CU NIPDAU	Level-3-260C-168 HR	
ISO7240MDWR	ACTIVE	SOIC	DW	16	2000	Green (RoHS & no Sb/Br)	CU NIPDAU	Level-3-260C-168 HR	
ISO7240MDWRG4	ACTIVE	SOIC	DW	16	2000	Green (RoHS & no Sb/Br)	CU NIPDAU	Level-3-260C-168 HR	
ISO7241CDW	ACTIVE	SOIC	DW	16	40	Green (RoHS & no Sb/Br)	CU NIPDAU	Level-3-260C-168 HR	
ISO7241CDWG4	ACTIVE	SOIC	DW	16	40	Green (RoHS & no Sb/Br)	CU NIPDAU	Level-3-260C-168 HR	
ISO7241CDWR	ACTIVE	SOIC	DW	16	2000	Green (RoHS & no Sb/Br)	CU NIPDAU	Level-3-260C-168 HR	
ISO7241CDWRG4	ACTIVE	SOIC	DW	16	2000	Green (RoHS & no Sb/Br)	CU NIPDAU	Level-3-260C-168 HR	
ISO7241MDW	ACTIVE	SOIC	DW	16	40	Green (RoHS & no Sb/Br)	CU NIPDAU	Level-3-260C-168 HR	

Orderable Device	Status ⁽¹⁾	Package Type	Package Drawing	Pins	Package Qty	Eco Plan ⁽²⁾	Lead/ Ball Finish	MSL Peak Temp ⁽³⁾	Samples (Requires Login)
ISO7241MDWG4	ACTIVE	SOIC	DW	16	40	Green (RoHS & no Sb/Br)	CU NIPDAU	Level-3-260C-168 HR	
ISO7241MDWR	ACTIVE	SOIC	DW	16	2000	Green (RoHS & no Sb/Br)	CU NIPDAU	Level-3-260C-168 HR	
ISO7241MDWRG4	ACTIVE	SOIC	DW	16	2000	Green (RoHS & no Sb/Br)	CU NIPDAU	Level-3-260C-168 HR	
ISO7242CDW	ACTIVE	SOIC	DW	16	40	Green (RoHS & no Sb/Br)	CU NIPDAU	Level-3-260C-168 HR	
ISO7242CDWG4	ACTIVE	SOIC	DW	16	40	Green (RoHS & no Sb/Br)	CU NIPDAU	Level-3-260C-168 HR	
ISO7242CDWR	ACTIVE	SOIC	DW	16	2000	Green (RoHS & no Sb/Br)	CU NIPDAU	Level-3-260C-168 HR	
ISO7242CDWRG4	ACTIVE	SOIC	DW	16	2000	Green (RoHS & no Sb/Br)	CU NIPDAU	Level-3-260C-168 HR	
ISO7242MDW	ACTIVE	SOIC	DW	16	40	Green (RoHS & no Sb/Br)	CU NIPDAU	Level-3-260C-168 HR	
ISO7242MDWG4	ACTIVE	SOIC	DW	16	40	Green (RoHS & no Sb/Br)	CU NIPDAU	Level-3-260C-168 HR	
ISO7242MDWR	ACTIVE	SOIC	DW	16	2000	Green (RoHS & no Sb/Br)	CU NIPDAU	Level-3-260C-168 HR	
ISO7242MDWRG4	ACTIVE	SOIC	DW	16	2000	Green (RoHS & no Sb/Br)	CU NIPDAU	Level-3-260C-168 HR	

⁽¹⁾ The marketing status values are defined as follows:

ACTIVE: Product device recommended for new designs.

LIFEBUY: TI has announced that the device will be discontinued, and a lifetime-buy period is in effect.

NRND: Not recommended for new designs. Device is in production to support existing customers, but TI does not recommend using this part in a new design.

PREVIEW: Device has been announced but is not in production. Samples may or may not be available.

OBSOLETE: TI has discontinued the production of the device.

⁽²⁾ Eco Plan - The planned eco-friendly classification: Pb-Free (RoHS), Pb-Free (RoHS Exempt), or Green (RoHS & no Sb/Br) - please check <http://www.ti.com/productcontent> for the latest availability information and additional product content details.

TBD: The Pb-Free/Green conversion plan has not been defined.

Pb-Free (RoHS): TI's terms "Lead-Free" or "Pb-Free" mean semiconductor products that are compatible with the current RoHS requirements for all 6 substances, including the requirement that lead not exceed 0.1% by weight in homogeneous materials. Where designed to be soldered at high temperatures, TI Pb-Free products are suitable for use in specified lead-free processes.

Pb-Free (RoHS Exempt): This component has a RoHS exemption for either 1) lead-based flip-chip solder bumps used between the die and package, or 2) lead-based die adhesive used between the die and leadframe. The component is otherwise considered Pb-Free (RoHS compatible) as defined above.

Green (RoHS & no Sb/Br): TI defines "Green" to mean Pb-Free (RoHS compatible), and free of Bromine (Br) and Antimony (Sb) based flame retardants (Br or Sb do not exceed 0.1% by weight in homogeneous material)

⁽³⁾ MSL, Peak Temp. -- The Moisture Sensitivity Level rating according to the JEDEC industry standard classifications, and peak solder temperature.

Important Information and Disclaimer: The information provided on this page represents TI's knowledge and belief as of the date that it is provided. TI bases its knowledge and belief on information provided by third parties, and makes no representation or warranty as to the accuracy of such information. Efforts are underway to better integrate information from third parties. TI has taken and continues to take reasonable steps to provide representative and accurate information but may not have conducted destructive testing or chemical analysis on incoming materials and chemicals. TI and TI suppliers consider certain information to be proprietary, and thus CAS numbers and other limited information may not be available for release.

In no event shall TI's liability arising out of such information exceed the total purchase price of the TI part(s) at issue in this document sold by TI to Customer on an annual basis.

OTHER QUALIFIED VERSIONS OF ISO7240CF, ISO7241C, ISO7242C :

- Automotive: [ISO7240CF-Q1](#), [ISO7241C-Q1](#), [ISO7242C-Q1](#)

NOTE: Qualified Version Definitions:

- Automotive - Q100 devices qualified for high-reliability automotive applications targeting zero defects

TAPE AND REEL INFORMATION



QUADRANT ASSIGNMENTS FOR PIN 1 ORIENTATION IN TAPE



*All dimensions are nominal

Device	Package Type	Package Drawing	Pins	SPQ	Reel Diameter (mm)	Reel Width W1 (mm)	A0 (mm)	B0 (mm)	K0 (mm)	P1 (mm)	W (mm)	Pin1 Quadrant
ISO7240CDWR	SOIC	DW	16	2000	330.0	16.4	10.75	10.7	2.7	12.0	16.0	Q1
ISO7240CFDWR	SOIC	DW	16	2000	330.0	16.4	10.75	10.7	2.7	12.0	16.0	Q1
ISO7240MDWR	SOIC	DW	16	2000	330.0	16.4	10.75	10.7	2.7	12.0	16.0	Q1
ISO7241CDWR	SOIC	DW	16	2000	330.0	16.4	10.75	10.7	2.7	12.0	16.0	Q1
ISO7242CDWR	SOIC	DW	16	2000	330.0	16.4	10.75	10.7	2.7	12.0	16.0	Q1

TAPE AND REEL BOX DIMENSIONS

*All dimensions are nominal

Device	Package Type	Package Drawing	Pins	SPQ	Length (mm)	Width (mm)	Height (mm)
ISO7240CDWR	SOIC	DW	16	2000	367.0	367.0	38.0
ISO7240CFDWR	SOIC	DW	16	2000	367.0	367.0	38.0
ISO7240MDWR	SOIC	DW	16	2000	367.0	367.0	38.0
ISO7241CDWR	SOIC	DW	16	2000	367.0	367.0	38.0
ISO7242CDWR	SOIC	DW	16	2000	367.0	367.0	38.0

DW (R-PDSO-G16)

PLASTIC SMALL OUTLINE

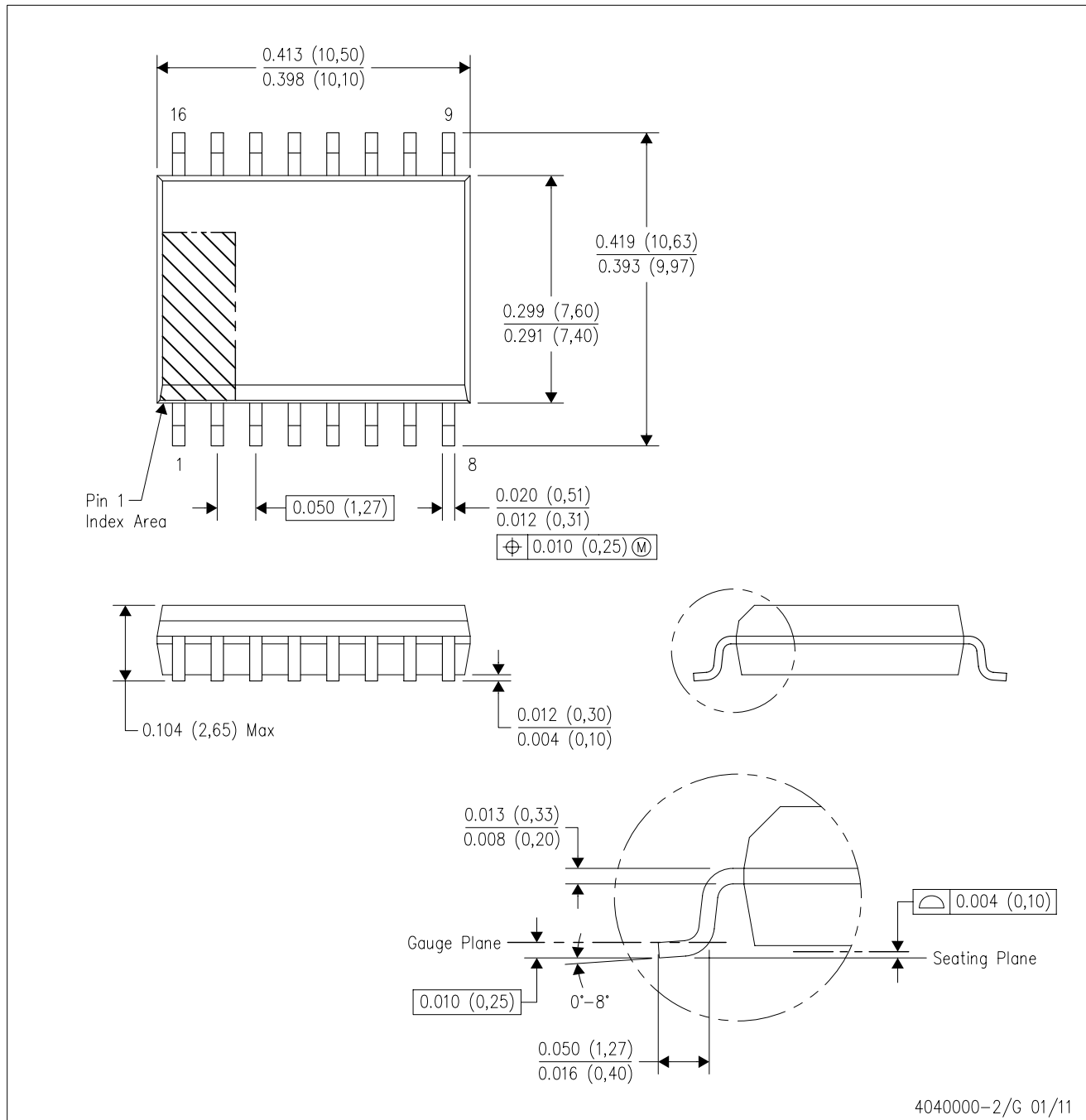

- NOTES:
- All linear dimensions are in inches (millimeters). Dimensioning and tolerancing per ASME Y14.5M-1994.
 - This drawing is subject to change without notice.
 - Body dimensions do not include mold flash or protrusion not to exceed 0.006 (0,15).
 - Falls within JEDEC MS-013 variation AA.

DW (R-PDSO-G16)

PLASTIC SMALL OUTLINE

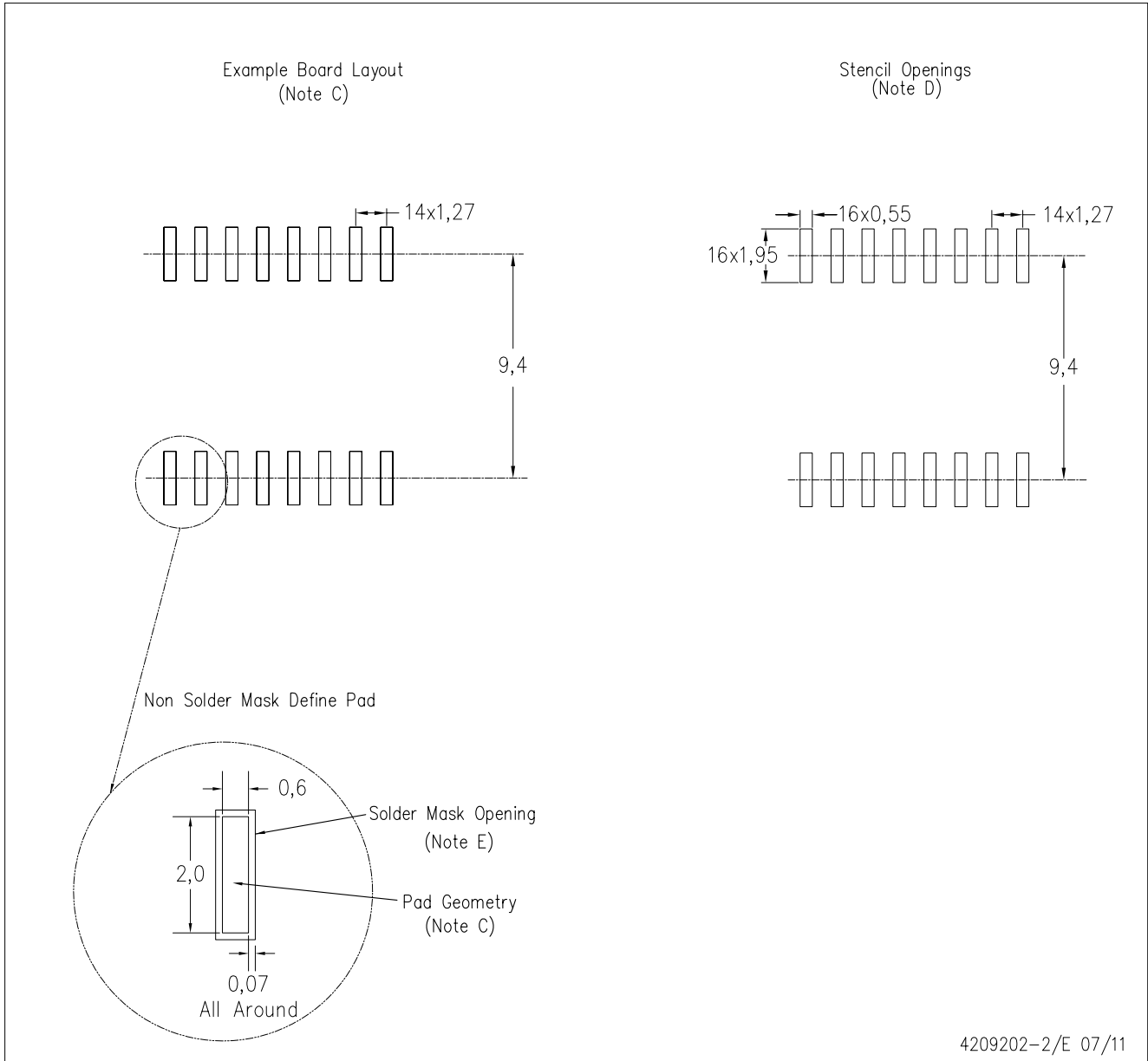

4209202-2/E 07/11

- NOTES:
- A. All linear dimensions are in millimeters.
 - B. This drawing is subject to change without notice.
 - C. Refer to IPC7351 for alternate board design.
 - D. Laser cutting apertures with trapezoidal walls and also rounding corners will offer better paste release. Customers should contact their board assembly site for stencil design recommendations. Refer to IPC-7525
 - E. Customers should contact their board fabrication site for solder mask tolerances between and around signal pads.

IMPORTANT NOTICE

Texas Instruments Incorporated and its subsidiaries (TI) reserve the right to make corrections, enhancements, improvements and other changes to its semiconductor products and services per JESD46, latest issue, and to discontinue any product or service per JESD48, latest issue. Buyers should obtain the latest relevant information before placing orders and should verify that such information is current and complete. All semiconductor products (also referred to herein as "components") are sold subject to TI's terms and conditions of sale supplied at the time of order acknowledgment.

TI warrants performance of its components to the specifications applicable at the time of sale, in accordance with the warranty in TI's terms and conditions of sale of semiconductor products. Testing and other quality control techniques are used to the extent TI deems necessary to support this warranty. Except where mandated by applicable law, testing of all parameters of each component is not necessarily performed.

TI assumes no liability for applications assistance or the design of Buyers' products. Buyers are responsible for their products and applications using TI components. To minimize the risks associated with Buyers' products and applications, Buyers should provide adequate design and operating safeguards.

TI does not warrant or represent that any license, either express or implied, is granted under any patent right, copyright, mask work right, or other intellectual property right relating to any combination, machine, or process in which TI components or services are used. Information published by TI regarding third-party products or services does not constitute a license to use such products or services or a warranty or endorsement thereof. Use of such information may require a license from a third party under the patents or other intellectual property of the third party, or a license from TI under the patents or other intellectual property of TI.

Reproduction of significant portions of TI information in TI data books or data sheets is permissible only if reproduction is without alteration and is accompanied by all associated warranties, conditions, limitations, and notices. TI is not responsible or liable for such altered documentation. Information of third parties may be subject to additional restrictions.

Resale of TI components or services with statements different from or beyond the parameters stated by TI for that component or service voids all express and any implied warranties for the associated TI component or service and is an unfair and deceptive business practice. TI is not responsible or liable for any such statements.

Buyer acknowledges and agrees that it is solely responsible for compliance with all legal, regulatory and safety-related requirements concerning its products, and any use of TI components in its applications, notwithstanding any applications-related information or support that may be provided by TI. Buyer represents and agrees that it has all the necessary expertise to create and implement safeguards which anticipate dangerous consequences of failures, monitor failures and their consequences, lessen the likelihood of failures that might cause harm and take appropriate remedial actions. Buyer will fully indemnify TI and its representatives against any damages arising out of the use of any TI components in safety-critical applications.

In some cases, TI components may be promoted specifically to facilitate safety-related applications. With such components, TI's goal is to help enable customers to design and create their own end-product solutions that meet applicable functional safety standards and requirements. Nonetheless, such components are subject to these terms.

No TI components are authorized for use in FDA Class III (or similar life-critical medical equipment) unless authorized officers of the parties have executed a special agreement specifically governing such use.

Only those TI components which TI has specifically designated as military grade or "enhanced plastic" are designed and intended for use in military/aerospace applications or environments. Buyer acknowledges and agrees that any military or aerospace use of TI components which have **not** been so designated is solely at the Buyer's risk, and that Buyer is solely responsible for compliance with all legal and regulatory requirements in connection with such use.

TI has specifically designated certain components which meet ISO/TS16949 requirements, mainly for automotive use. Components which have not been so designated are neither designed nor intended for automotive use; and TI will not be responsible for any failure of such components to meet such requirements.

Products

Audio	www.ti.com/audio
Amplifiers	amplifier.ti.com
Data Converters	dataconverter.ti.com
DLP® Products	www.dlp.com
DSP	dsp.ti.com
Clocks and Timers	www.ti.com/clocks
Interface	interface.ti.com
Logic	logic.ti.com
Power Mgmt	power.ti.com
Microcontrollers	microcontroller.ti.com
RFID	www.ti-rfid.com
OMAP Applications Processors	www.ti.com/omap
Wireless Connectivity	www.ti.com/wirelessconnectivity

Applications

Automotive and Transportation	www.ti.com/automotive
Communications and Telecom	www.ti.com/communications
Computers and Peripherals	www.ti.com/computers
Consumer Electronics	www.ti.com/consumer-apps
Energy and Lighting	www.ti.com/energy
Industrial	www.ti.com/industrial
Medical	www.ti.com/medical
Security	www.ti.com/security
Space, Avionics and Defense	www.ti.com/space-avionics-defense
Video and Imaging	www.ti.com/video

TI E2E Community

e2e.ti.com