

SPECIFICATIONS

PARAMETERS	VALUES	UNITS
RATED INPUT POWER	5	W
MAX INPUT POWER	8	W
IMPEDANCE	8 ± 15%	OHM
OUTPUT SPL @ 1W/0.5M (AT 0.6, 0.8, 1.0, 1.2 kHz)	87 ± 3	dB
DISTORTION (MAX.)	3%	-
RESONANT FREQUENCY	200 ± 20%	Hz
FREQUENCY RANGE	Fo ~ 20,000	Hz
HOUSING MATERIAL	METAL	-
CONE MATERIAL	PAPER	-
MAGNET MATERIAL	FERRITE	-
OPERATING TEMPERATURE	-25 ~ +70	°C
WEIGHT	118	grams

THIS DOCUMENT CONTAINS DATA PROPRIETARY TO PROJECTS UNLIMITED, INC. ANY USE OR REPRODUCTION, IN ANY FORM, WITHOUT PRIOR WRITTEN PERMISSION OF PROJECTS UNLIMITED, INC. IS PROHIBITED.
©2003, Projects Unlimited Inc.

REVISION HISTORY

LTR	DESCRIPTION	DATE	APPROVED
-	RELEASED FROM ENGINEERING	8/16/2005	
A	REVISED MAGNET DIAMETER	12/19/2007	R.W.
B	REVISED HEIGHT & HOLE DIMENSIONS	1/29/2009	B.R.
C	REVISED TO INVENTOR 3-D DRAWING TEMPLATE	1/29/2009	B.R.
D	REVISED OPERATING TEMPERATURE	2/9/2012	C.W.
E	REVISED WIDTH, HOLE, MAGNET & HEIGHT DIMS. AND SPECS.	7/5/2013	M.L.
F	REVISED ELECTRICAL PARAMETERS AND DIMENSIONS	7/15/2014	M.L.

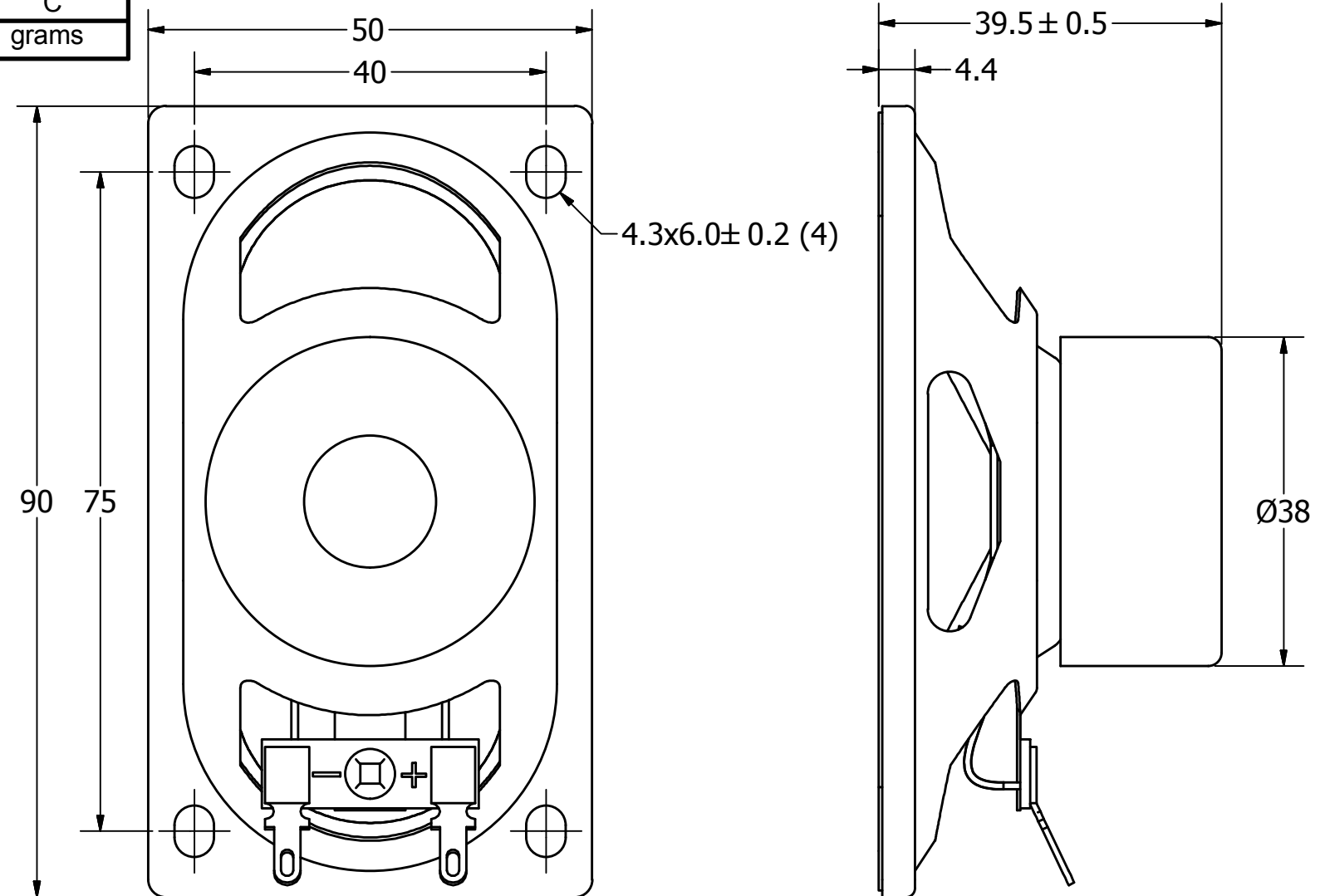

NOTES:

1. ALL DIMENSIONS ARE IN MILLIMETERS.
2. SPECIFICATIONS SUBJECT TO CHANGE OR WITHDRAWL WITHOUT NOTICE.
3. THIS PART IS RoHS 2011/65/EU COMPLIANT.

UNLESS OTHERWISE SPECIFIED: DIMENSIONS ARE IN MILLIMETERS, TOLERANCES ARE ±0.5 AND ANGLES ARE ±3°.	SIZE A3	Designed by	Date	Checked by	Date	Approved by	Date	Drawn Date
		J.A.F.	8/16/2005	B.R.	8/16/2005	E.P.	8/16/2005	1/29/2009
AS09008PO-2-R.idw		 pui audio inc <small>a projects unlimited company</small>		AS09008PO-2-R Speaker		Edition	Sheet	
						-	1 / 1	