

METRIC
 DIMENSIONS LISTED IN mm [INCHES]

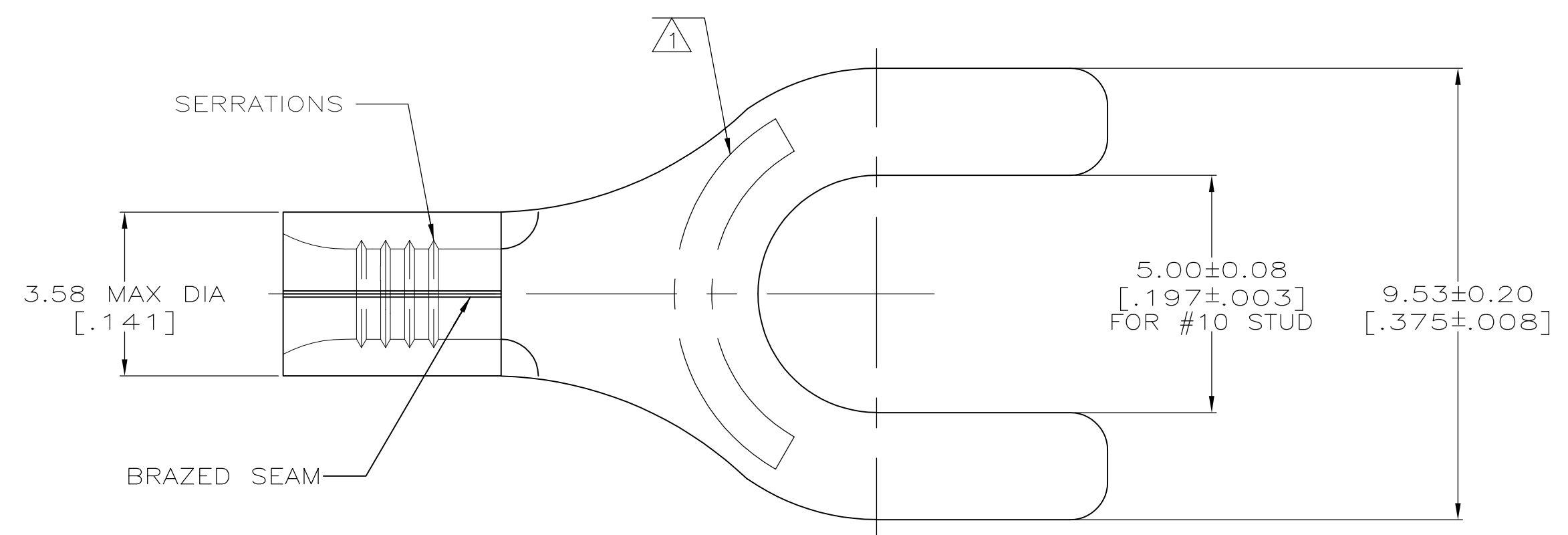

AMP WIRE RANGE	E13288 Listed
22-16 AWG SOLID OR STRANDED	22-16 AWG SOLID OR STRANDED
LR7189 Certified	MILITARY P/N AND CLASS
22-16 AWG SOLID OR STRANDED	NOT APPLICABLE

△ STAMP AMP 22-18* APPROX AS SHOWN
 22-16 TERMINALS ARE STAMPED 22-18 IN
 ACCORDANCE WITH MILITARY SPECIFICATION
 MIL-T-7928; COMMERCIAL WIRE RANGE IS 22-16

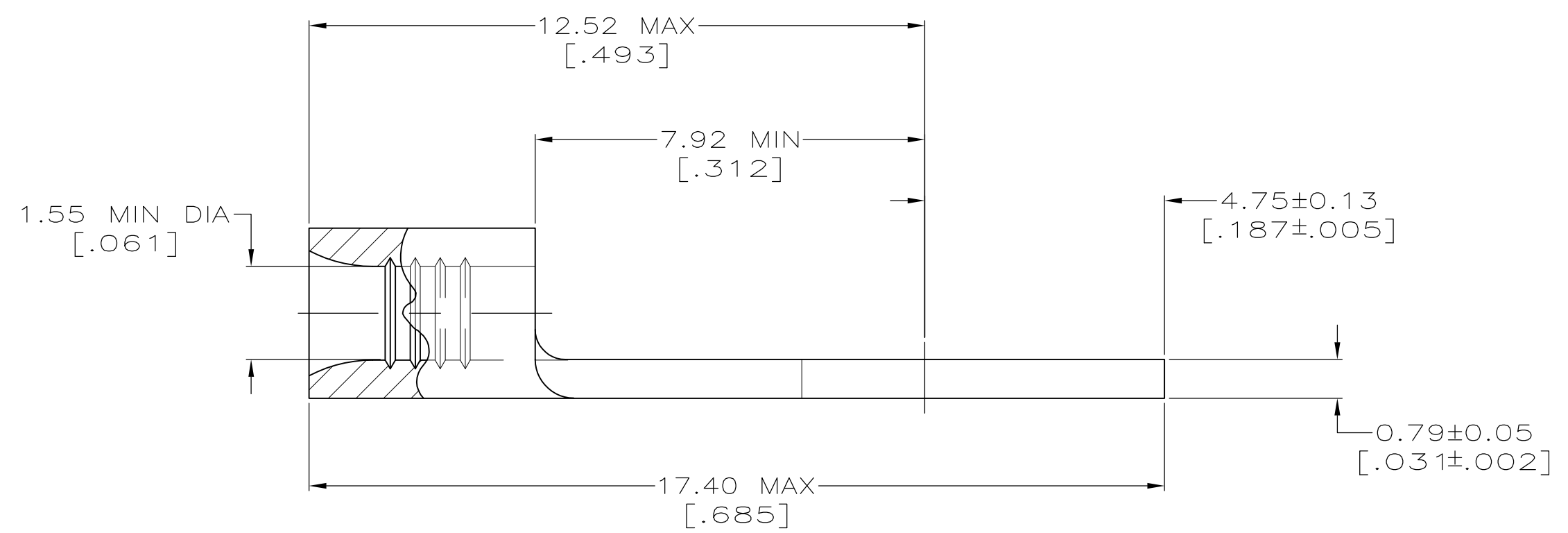

AMP INCORPORATED CUSTOMER SERVICE SYSTEMS		MAX RECOMMENDED OPERATING TEMPERATURE: 170° C MAX
FOR ADDITIONAL PRODUCT INFORMATION OR COPIES OF DRAWINGS AND TECHNICAL DOCUMENTS	PRODUCT INFORMATION CENTER 1-800-522-6752	VOLTAGE RATING: NOT APPLICABLE
FOR APPLICATION TOOLING INFORMATION	TOOLING ASSISTANCE CENTER 1-800-722-1111	WIRE CROSS SECTIONAL AREA RANGE: 0.26-1.65mm ² [509-3,260] CIR MILS SOLID OR STRANDED
FOR ORDER ENTRY	1-800-526-5142	THIS DRAWING IS A CONTROLLED DOCUMENT FOR AMP INCORPORATED. IT IS SUBJECT TO CHANGE AND THE CONTROLLING ENGINEERING ORGANIZATION SHOULD BE CONTACTED FOR THE LATEST REVISION.

100	LOOSE PIECE, BOX SPECIAL (NO WINDOW)	8-34118-5
5000	ON TAPE	2-34118-2
---	LOOSE PIECE	34118
QUANTITY	PACKAGING TYPE	PART NO

THIS DRAWING IS A CONTROLLED DOCUMENT.		DWN TA BRINKMAN 3-26-93	TE Connectivity	
DIMENSIONS: MM[INCHES]		CHK DA PATTERSON 3-26-93	NAME DE MILLER 3-26-93	
TOLERANCES UNLESS OTHERWISE SPECIFIED:		APVD DE MILLER 3-26-93	PRODUCT SPEC	
0 PLC ± -		APPLICATION SPEC		
1 PLC ± -		WEIGHT		
2 PLC ± -		SIZE A2		
3 PLC ± -		CAGE CODE 00779		
4 PLC ± -		DRAWING NO G-34118		
ANGLES ± ± -		RESTRICTED TO		
MATERIAL COPPER PER ASTM B-152 ANNEALED	FINISH TIN PLATE 0.00254[.000100] MIN THK PER MIL-T-10727	CUSTOMER DRAWING		
		SCALE 10:1	SHEET 1 of 1	REV F1