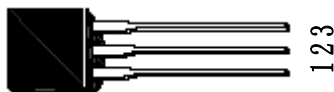
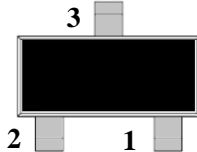

1、Features

- Lead(Pb)-Free
- Collector Current: $I_C=1.5A$
- Collector Power Dissipation: $P_C=1W(T_C=25^\circ C)$
- Complimentary to SS8550

2、Pinning information

PIN	Description	Simplified outline	
1	Emitter(E)		
2	Base(B)		
3	Collector(C)		
		TO-92	SOT-23

3、Limiting value

($T_a = 25^\circ C$ unless otherwise noted).

SYMBOL	PARAMETER	Limit	UNIT
Vcbo	Collector-Base Voltage	40	V
Vceo	Collector-Emitter Voltage	25	V
Vebo	Emitter-Base Voltage	6	V
Ic	Collector Current	1.5	A
Pc	Collector Power Dissipation	TO-92	1.0
		SOT-23	0.36
Tj	Junction Temperature	+150	°C
Tstg	Storage Temperature	-55 to +150	°C

4、Electrical Characteristics ($T_a = 25^\circ C$ unless otherwise noted)

SYMBOL	PARAMETER	CONDITIONS	MIN	Typ	MAX	UNIT
BVcbo	Collector-Base Breakdown Voltage	$I_C = 100\mu A, I_B = 0$	40			V
Bvceo	Collector-Emitter Breakdown Voltage	$I_C = 2mA, I_E = 0$	25			V
Bvebo	Emitter-Base Breakdown Voltage	$I_E = 100\mu A, I_C = 0$	6			V
Icbo	Collector Cut-off Current	$V_{CB} = 35V, I_E = 0$			100	nA
Iebo	Emitter Cut-off Current	$V_{EB} = 6V, I_C = 0$			100	nA
Vce(sat)	Collector-Emitter Saturation Voltage	$I_C=800mA$ $I_B=80mA$			0.5	V
Vbe(sat)	Base-Emitter Saturation Voltage	$I_C=800mA$ $I_B=80mA$			1.2	V
Vbe(on)	Base-Emitter On Voltage	$V_{CE} = 1V, I_C=10mA$			1.0	V
h_{FE}	DC Current Gain	$V_{CE} = 1V, I_C=100mA$	85		300	
f_T	Current Gain Bandwidth Product	$V_{CE}=10V, I_C= 50mA$	100			MHz
Cob	Output Capacitance	$V_{CB}=10V, f = 1MHz$		9.0		pF

h_{FE} Classification

Rank	B	C	D
Range	85-160	120-200	170-300

5. Electrical Characteristics Curve

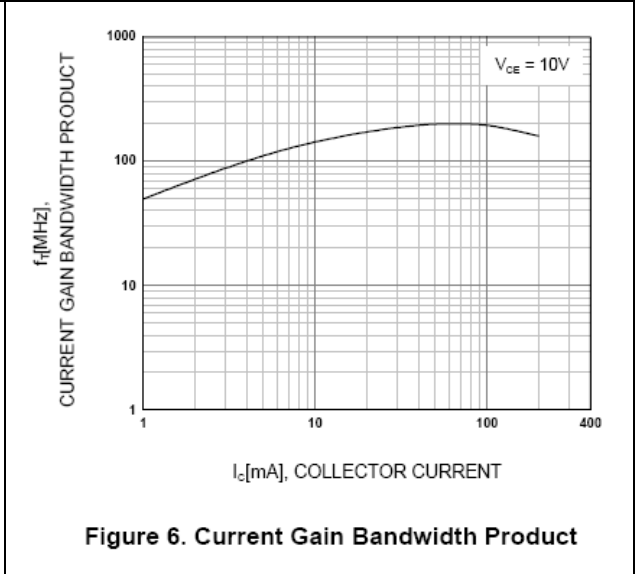
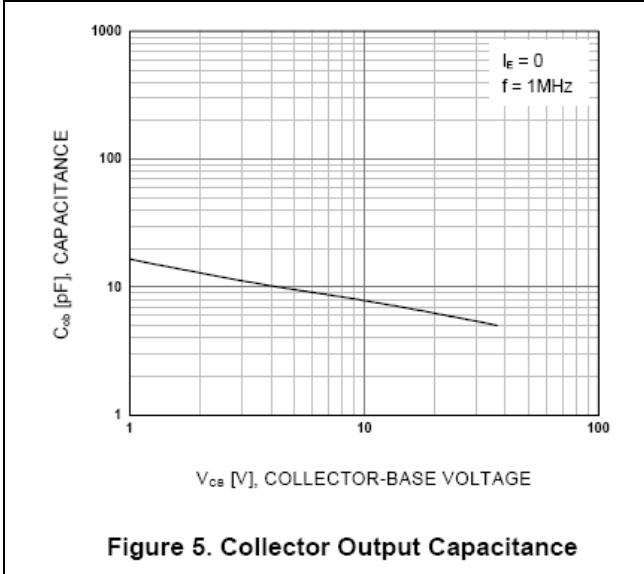
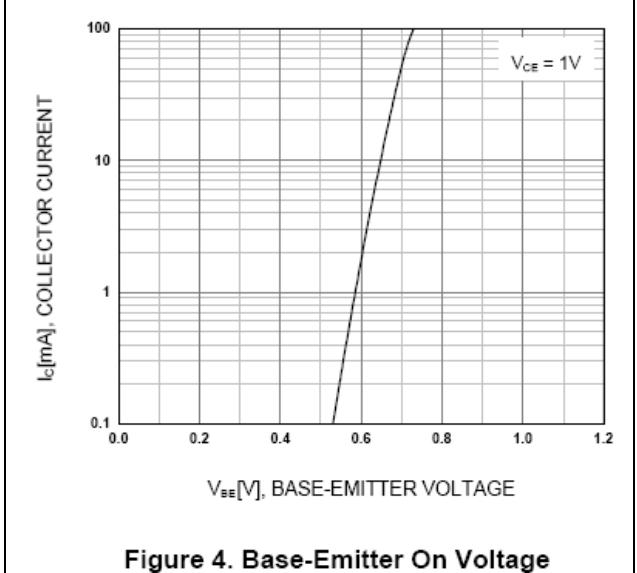
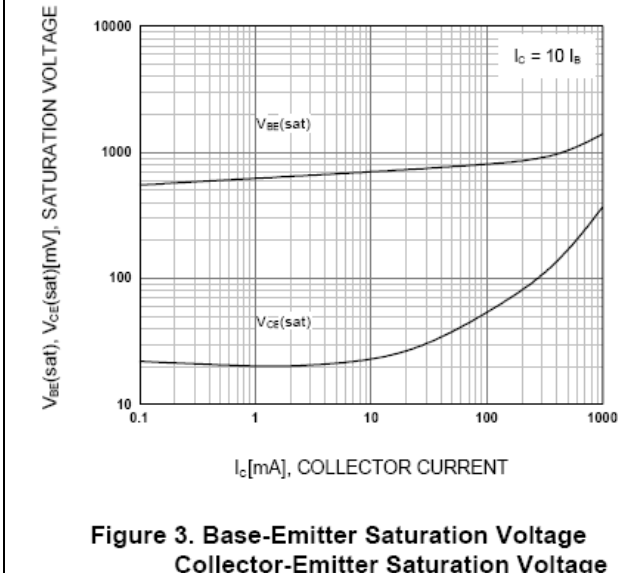
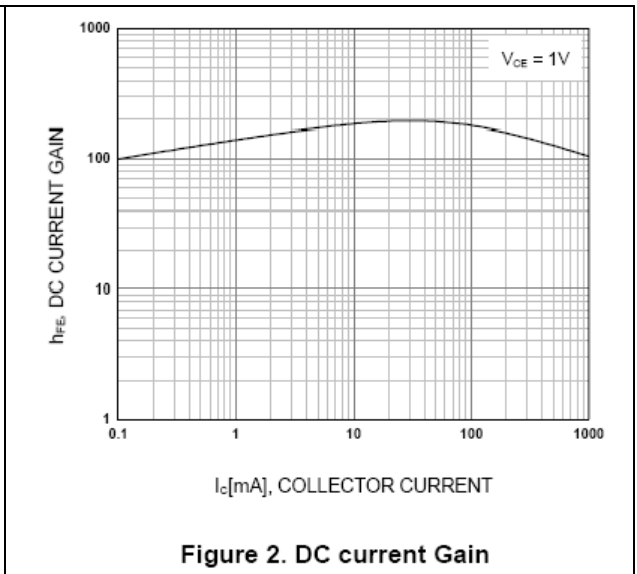
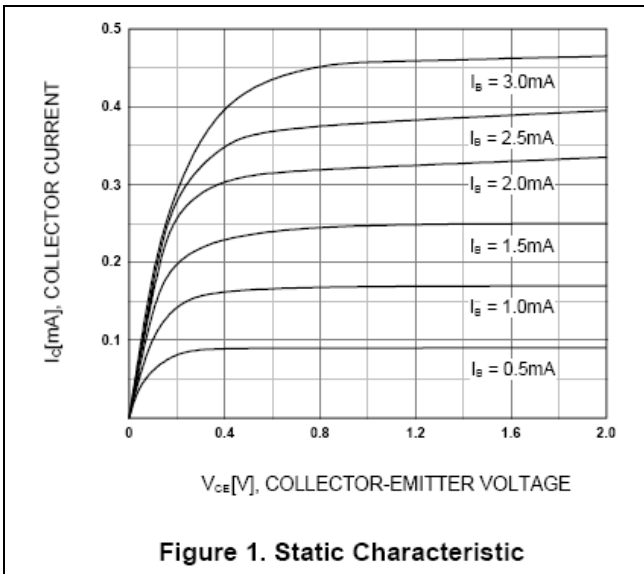

6. Package outline(TO-92)

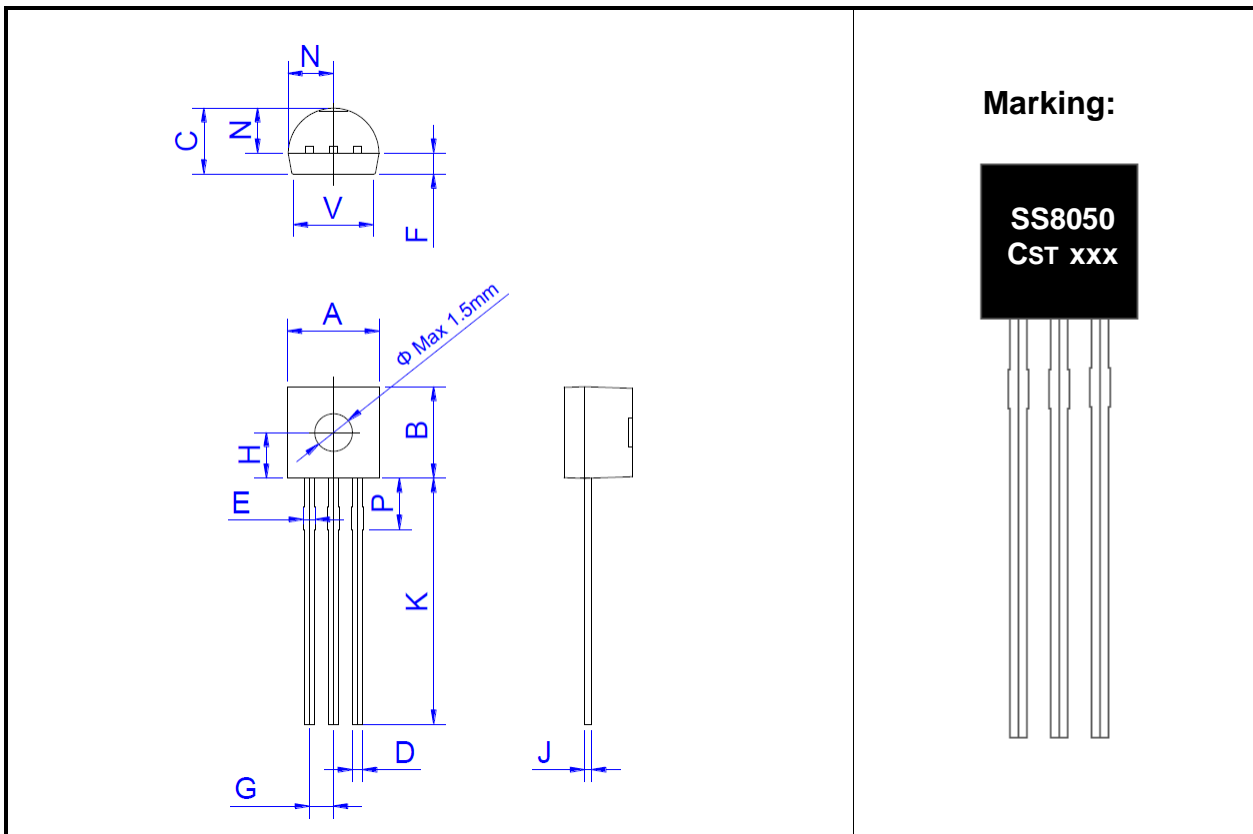

DIM	Inches			Millimeters		
	Min	Type	Max	Min	Type	Max
A	0.175	-	0.205	4.45	-	5.20
B	0.170	-	0.210	4.32	-	5.33
C	0.125	-	0.165	3.18	-	4.19
D	0.015	-	0.020	0.38	-	0.50
E	0.016	-	0.028	0.40	-	0.70
F	-	0.043	-	-	1.10	-
G	-	0.050	-	-	1.27	-
H	-	0.091	-	-	2.30	-
J	0.010	-	0.016	0.26	-	0.40
K	0.500	-	0.591	12.7	-	15.0
N	0.080	-	0.105	2.04	-	2.66
P	0.091	-	0.106	2.30	-	2.70
V	-	-	0.177	-	-	4.50

CST

7、TO-92 Tape and Reel

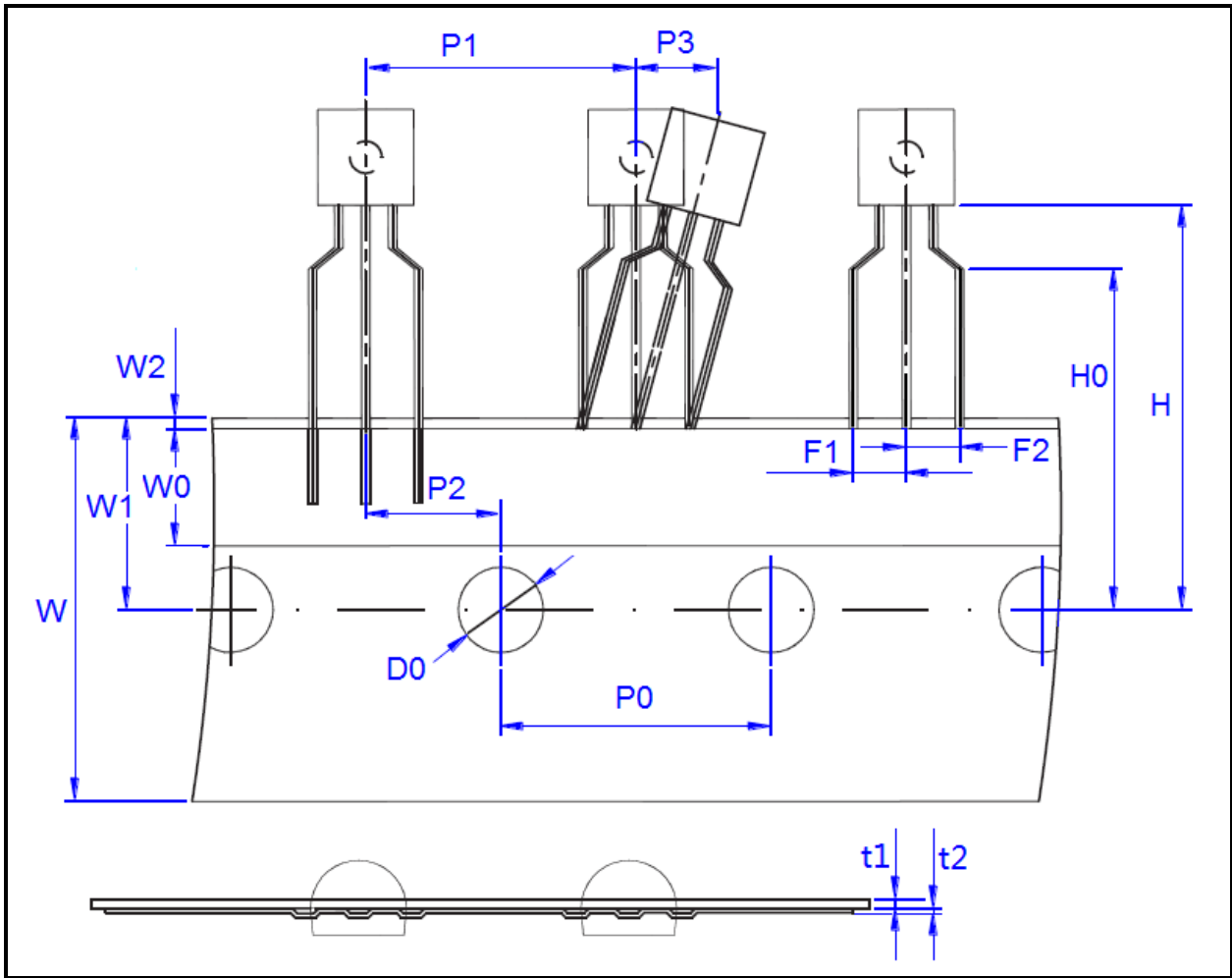

DIM	Inches			Millimeters		
	Min	Type	Max	Min	Type	Max
P1	-	0.500	-	-	12.7	-
P0	-	0.500	-	-	12.7	-
P2	-	0.250	-	-	6.35	-
F1	-	0.098	-	-	2.50	-
F2	-	0.098	-	-	2.50	-
W	-	0.709	-	-	18.0	-
W0	-	0.236	-	-	6.00	-
W1	-	0.354	-	-	9.00	-
W2	-	-	0.039	-	-	1.00
H	-	0.748	-	-	19.0	-
H0	-	0.630	-	-	16.0	-
D0	-	0.157	-	-	4.00	-
t0	-	0.016	-	-	0.40	-
t1	-	0.008	-	-	0.20	-
P3	-	0	-	-	0	-

CST

8、Package outline(SOT-23)

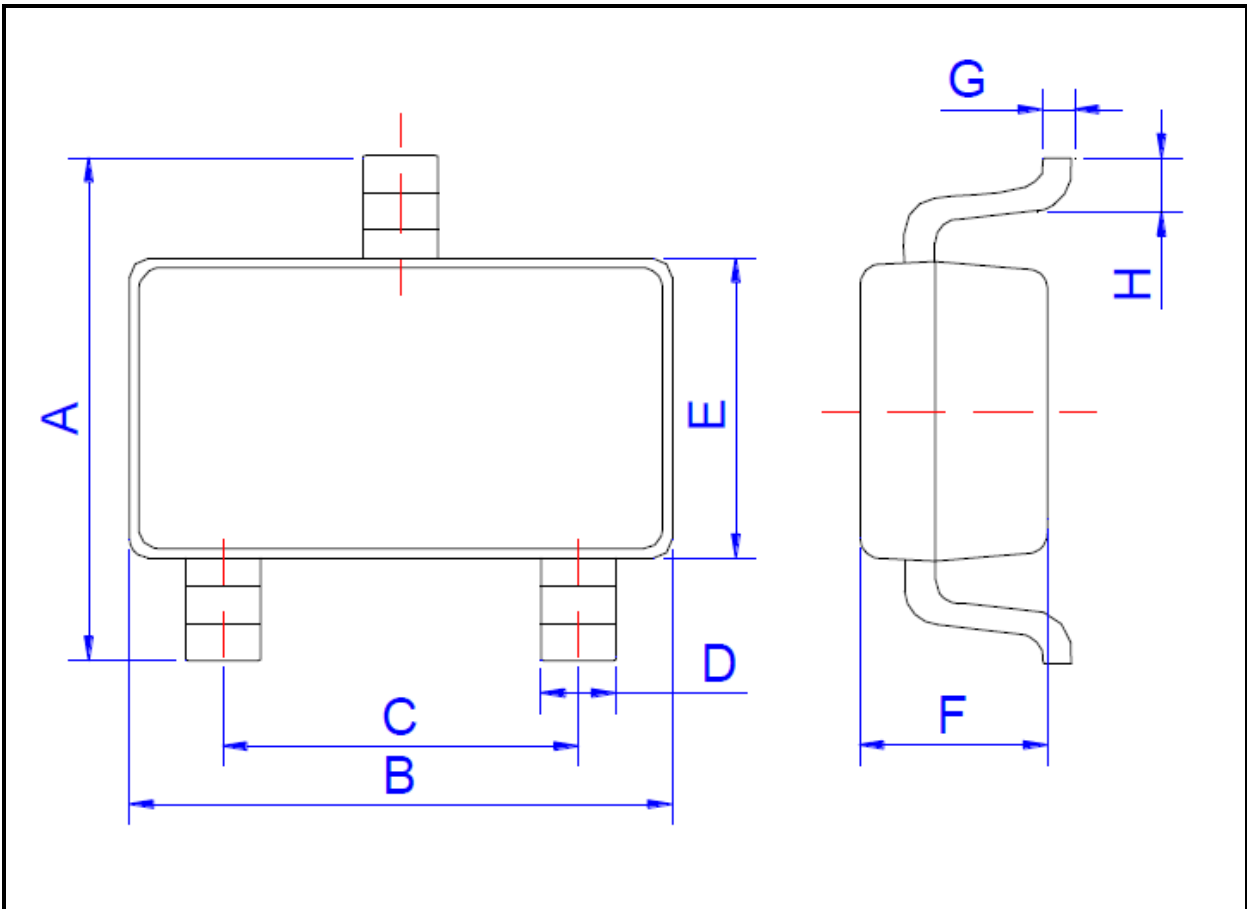

DIM	Inches			Millimeters		
	Min	Type	Max	Min	Type	Max
A	0.104		0.116	2.65		2.95
B		0.115			2.92	
C		0.075			1.90	
D	0.014		0.018	0.35		0.45
E		0.051			1.30	
F		0.043			1.10	
G		0.006			0.16	
H	0.010		0.022	0.25		0.55