

## 2 Watt C-Band VSAT Power Amplifier 5.9 - 7.1 GHz

Rev. V5

### Features

- High Linear Gain: 33 dB Typical
- High Saturated Output Power: +33 dBm Typ.
- High Power Added Efficiency: 25% Typ.
- 50  $\Omega$  Input / Output Broadband Matched
- Integrated Output Power Detector
- Lead-Free Bolt Down Ceramic Package
- RoHS\* Compliant and 260°C Reflow Compatible

### Description

The AM42-0039 is a three stage MMIC power amplifier in a lead-free, bolt down ceramic package, allowing easy assembly. This device employs a fully matched chip with internally decoupled gate and drain bias networks. The device is designed to operate from a constant current drain supply or a constant voltage gate supply. By varying the bias conditions, the saturated output power performance of this device may be tailored for various applications.

The AM42-0039 is ideally suited for use as an output stage or a driver amplifier in VSAT systems. The AM42-0039 includes internal supply line bypassing in the package, minimizing the number of external components required.

The AM42-0039 is fabricated using a mature 0.5 micron MBE based GaAs MESFET process. The process features full passivation for increased performance and reliability. This product is 100% RF tested to ensure compliance to performance specifications.

### Ordering Information

Part Number	Package
AM42-0039	CR-15 Ceramic Bolt Down Package

### Functional Schematic

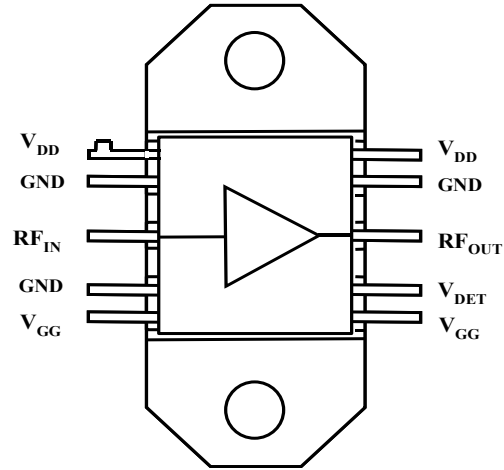

### Pin Configuration

Pin No.	Pin Name	Description
1	V <sub>DD</sub>	Drain Supply
2	GND	DC and RF Ground
3	RF <sub>IN</sub>	RF Input
4	GND	DC and RF Ground
5	V <sub>GG</sub>	Gate Supply
6	V <sub>GG</sub>	Gate Supply
7	V <sub>DET</sub>	Output Power Detector
8	RF <sub>OUT</sub>	RF Output
9	GND	DC and RF Ground
10	V <sub>DD</sub>	Drain Supply
Flange	GND	DC and RF Ground

\* Restrictions on Hazardous Substances, European Union Directive 2002/95/EC.

## 2 Watt C-Band VSAT Power Amplifier 5.9 - 7.1 GHz

Rev. V5

**Electrical Specifications:  $T_A = +25^\circ\text{C}$ ,  $V_{DD} = +8\text{ V}$ ,  $V_{GG}$  adjusted for  $I_{DD} = 900\text{ mA}$ ,  $F = 5.9 - 7.1$**

Parameter	Test Conditions	Units	Min.	Typ.	Max.
Linear Gain	$P_{IN} = -10\text{ dBm}$	dB	31	33	35
Input VSWR	$P_{IN} = -10\text{ dBm}$	Ratio	—	2.5:1	3.0:1
Output VSWR	$P_{IN} = -10\text{ dBm}$	Ratio	—	2.5:1	—
Output Power	$P_{IN} = +3\text{ dBm}$ , $I_{ds} = 900\text{ mA Typ.}$	dBm	31.7	33.0	—
Output Power vs. Frequency	$P_{IN} = +3\text{ dBm}$ , $I_{ds} = 900\text{ mA Typ.}$ (5.9 to 6.4 GHz)	dB	—	$\pm 0.3$	$\pm 0.75$
	$P_{IN} = +3\text{ dBm}$ , $I_{ds} = 900\text{ mA Typ.}$ (6.4 to 7.1 GHz)	dB	—	$\pm 0.3$	$\pm 0.75$
Output Power vs. Temperature	$T_A = -40^\circ\text{C to } +85^\circ\text{C}$ , $P_{IN} = +7\text{ dBm}$	dB	—	$\pm 0.4$	—
Drain Bias Current	$P_{IN} = +3\text{ dBm}$	mA	800	900	1000
Gate Bias Voltage	$P_{IN} = +3\text{ dBm}$ , $I_{ds} = 900\text{ mA Typ.}$	V	-2.0	-1.2	-0.4
Gate Bias Current	$P_{IN} = +3\text{ dBm}$ , $I_{ds} = 900\text{ mA Typ.}$	mA	—	10	20
Thermal Resistance (qJC)	25°C Heat Sink	°C/W	—	7.0	—
Second Harmonic	$P_{IN} = +3\text{ dBm}$ , $I_{ds} = 900\text{ mA Typ.}$	dBc	—	-35	—
Third Harmonic	$P_{IN} = +3\text{ dBm}$ , $I_{ds} = 900\text{ mA Typ.}$	dBc	—	-45	—
Detector Voltage	$P_{IN} = +3\text{ dBm}$ , $I_{ds} = 900\text{ mA Typ.}$	V	—	4.0	—

### Absolute Maximum Ratings<sup>1,2,3</sup>

Parameter	Absolute Maximum
Input Power	+15 dBm
Operating Voltages	$V_{DD} = +10\text{ volts};$ $V_{GG} = -3\text{ volts};$ $V_{DD} - V_{GG} = 12\text{ volts}$
$I_{ds}$	1200 mA
Channel Temperature	+150 °C
Operating Temperature	-40 °C to +80 °C
Storage Temperature	-65 °C to +150 °C

- Exceeding any one or combination of these limits may cause permanent damage to this device.
- M/A-COM does not recommend sustained operation near these survivability limits.
- Adequate heat sinking and grounding required on flange base.

### Operating the AM42-0039

The AM42-0039 is static sensitive. Please handle with care. To operate the device, follow these steps.

- Apply -2.0 Volts to  $V_{GG}$ .
- Ramp  $V_{DD}$  to +8V.
- Adjust  $V_{GG}$  to set quiescent drain current .
- Apply RF.
- Power down in reverse sequence. Turn gate voltage off last.

### Handling Procedures

Please observe the following precautions to avoid damage:

### Static Sensitivity

Gallium Arsenide Integrated Circuits are sensitive to electrostatic discharge (ESD) and can be damaged by static electricity. Proper ESD control techniques should be used when handling these devices.

## 2 Watt C-Band VSAT Power Amplifier 5.9 - 7.1 GHz

Rev. V5

### Lead-Free CR-15<sup>†</sup>

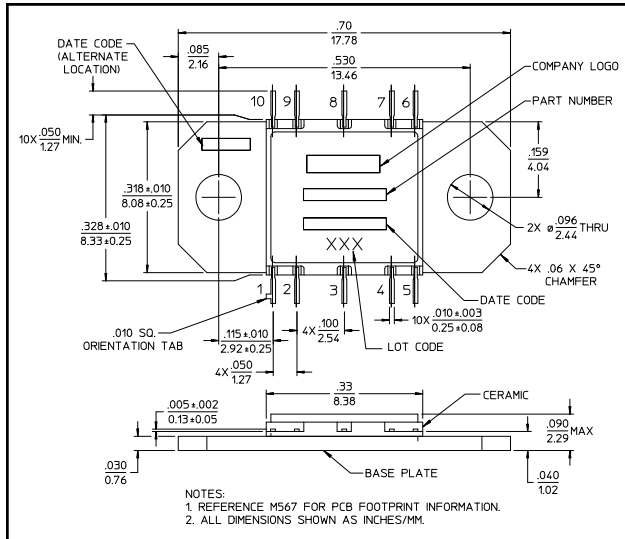

<sup>†</sup> Reference Application Note M538 for lead-free solder reflow recommendations.

### Application Schematic <sup>4,5,6</sup>

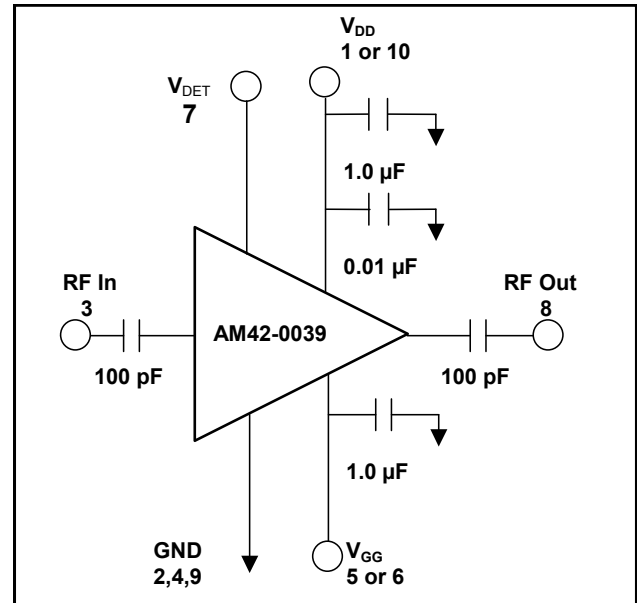

4. Apply -2 volts to pin 5 or 6 (V<sub>GG</sub>), prior to applying +8 volts to pins 1 or 10 (V<sub>DD</sub>). Adjust V<sub>GG</sub> for typical drain current.
5. External DC blocking capacitors required on the RF ports.
6. For optimum IP3 performance, V<sub>DD</sub> bypass capacitors should be placed within 0.5 inches of the V<sub>DD</sub> leads.

M/A-COM Technology Solutions Inc. All rights reserved.

Information in this document is provided in connection with M/A-COM Technology Solutions Inc ("MACOM") products. These materials are provided by MACOM as a service to its customers and may be used for informational purposes only. Except as provided in MACOM's Terms and Conditions of Sale for such products or in any separate agreement related to this document, MACOM assumes no liability whatsoever. MACOM assumes no responsibility for errors or omissions in these materials. MACOM may make changes to specifications and product descriptions at any time, without notice. MACOM makes no commitment to update the information and shall have no responsibility whatsoever for conflicts or incompatibilities arising from future changes to its specifications and product descriptions. No license, express or implied, by estoppel or otherwise, to any intellectual property rights is granted by this document.

THESE MATERIALS ARE PROVIDED "AS IS" WITHOUT WARRANTY OF ANY KIND, EITHER EXPRESS OR IMPLIED, RELATING TO SALE AND/OR USE OF MACOM PRODUCTS INCLUDING LIABILITY OR WARRANTIES RELATING TO FITNESS FOR A PARTICULAR PURPOSE, CONSEQUENTIAL OR INCIDENTAL DAMAGES, MERCHANTABILITY, OR INFRINGEMENT OF ANY PATENT, COPYRIGHT OR OTHER INTELLECTUAL PROPERTY RIGHT. MACOM FURTHER DOES NOT WARRANT THE ACCURACY OR COMPLETENESS OF THE INFORMATION, TEXT, GRAPHICS OR OTHER ITEMS CONTAINED WITHIN THESE MATERIALS. MACOM SHALL NOT BE LIABLE FOR ANY SPECIAL, INDIRECT, INCIDENTAL, OR CONSEQUENTIAL DAMAGES, INCLUDING WITHOUT LIMITATION, LOST REVENUES OR LOST PROFITS, WHICH MAY RESULT FROM THE USE OF THESE MATERIALS.

MACOM products are not intended for use in medical, lifesaving or life sustaining applications. MACOM customers using or selling MACOM products for use in such applications do so at their own risk and agree to fully indemnify MACOM for any damages resulting from such improper use or sale.