

Features
• Stratum 3
• ± 0.28 ppm Stability
• 12.8MHz
• Tape & Reel
• MSL : Level 3

Applications
• Si5348/83/84/88/89 Network Synchronizer Clocks
• Base Stations
• Wireless Applications
• Precision GPS

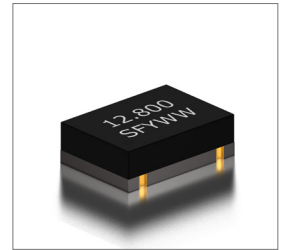

Part Numbering Guide



STX478 - 12.800M

Electrical Parameters	Units	Minimum	Typical	Maximum	Remarks
Frequency	MHz		12.800		
Frequency Tolerance at +25°C	ppm	-1.0		+1.0	
Freq. Stability vs, Op Temp.	ppm	-0.28		+0.28	Ref. to Freq. observed with $f_{ref} = (f_{max} + f_{min}) / 2$
Freq. Stability vs, Supply Voltage	ppm	-0.05		+0.05	V _{DD} $\pm 5\%$ Change
Freq. Stability vs, Load	ppm	-0.05		+0.05	$\pm 5\%$ Change
Freq. Stability vs, Aging/Day	ppm	-0.02		-0.02	
Freq. Stability vs, Aging/Year	ppm	-1.0		+1.0	
Operating Temperature	°C	-20		+75	
Storage Temperature	°C	-55		+105	
Supply Voltage (V _{DD})	V	3.13	3.3	3.47	
Current (I _{DD})	mA			10	
Output Load (HCMOS)	pF		15		
Output Logic HIGH Level (V _{OH})	V	2.4			
Output Logic LOW Level (V _{OL})	V			0.4	
Rise (T _R) And Fall (T _F) Time	ns			10	
Symmetry (Duty Cycle)	%	45	50	55	
Start-Up Time	ms			2	
Phase Noise 10Hz Offset	dBc/Hz		-85	-80	
Phase Noise 100Hz Offset	dBc/Hz		-115	-110	
Phase Noise 1KHz Offset	dBc/Hz		-135	-130	
Phase Noise 10KHz Offset	dBc/Hz		-145	-140	
Phase Noise 100KHz Offset	dBc/Hz		-145	-140	
Phase Noise 1MHz Offset	dBc/Hz		-150	-145	

Outline Drawing & Land Pattern

All dimensions are in millimeters (mm) unless otherwise noted. Drawings are not to scale.

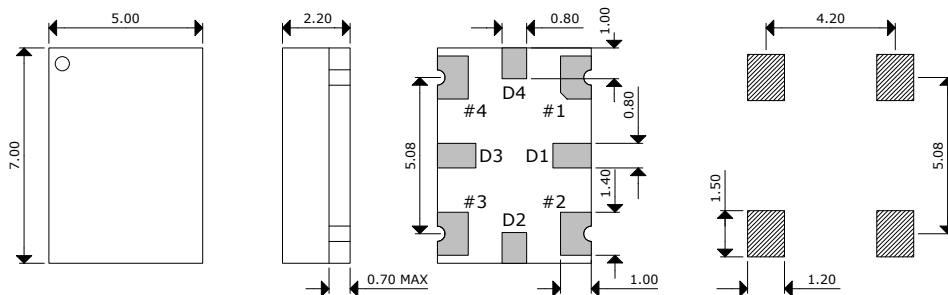

PIN	FUNCTION
1	NC
2	GND
3	OUTPUT
4	V _{DD}
D1, D2, D3, & D4 = NC	

Test Circuit (HCMOS)

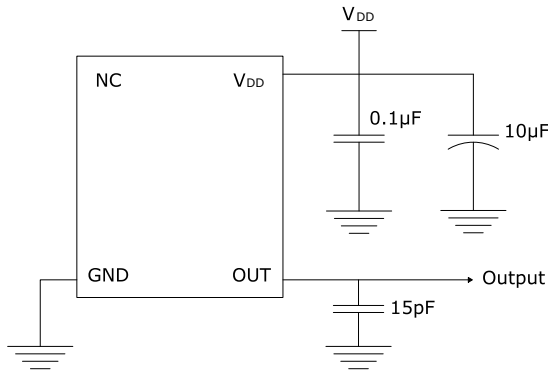

Waveform (HCMOS)

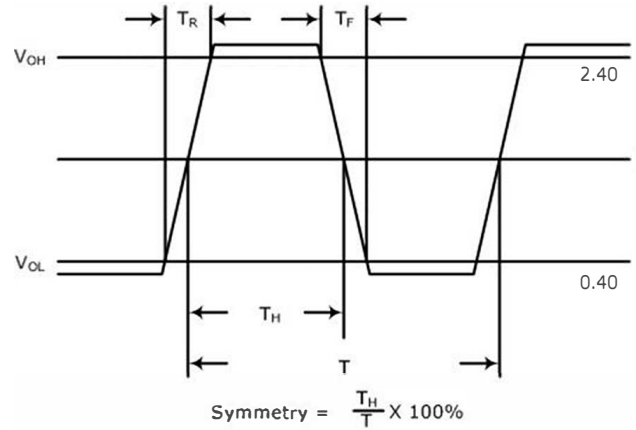

Typical Phase Noise Performance (Measured By Agilent E5052B)

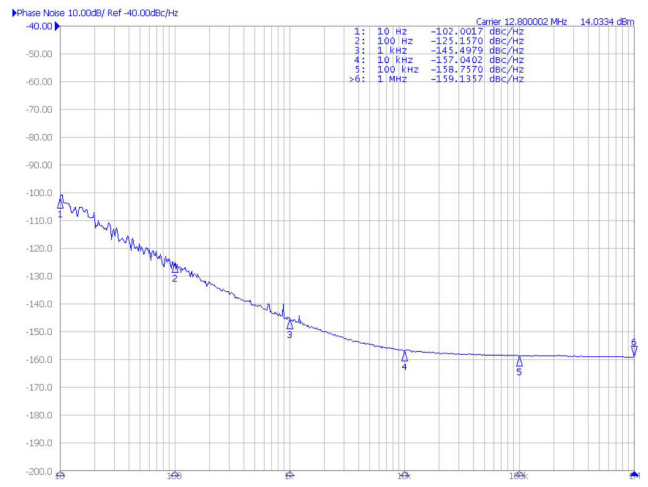
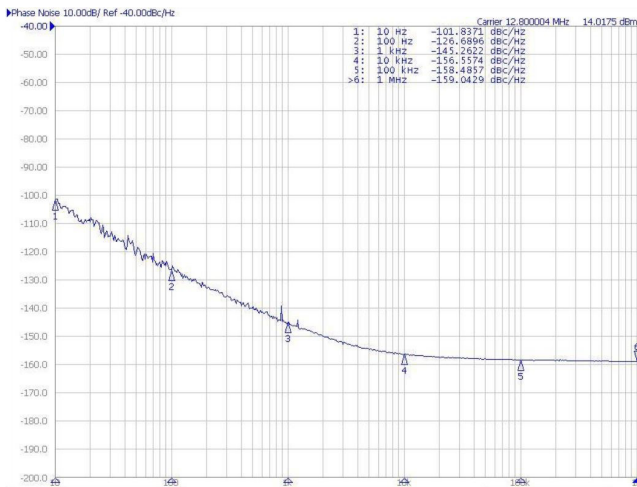

Reflow Profile

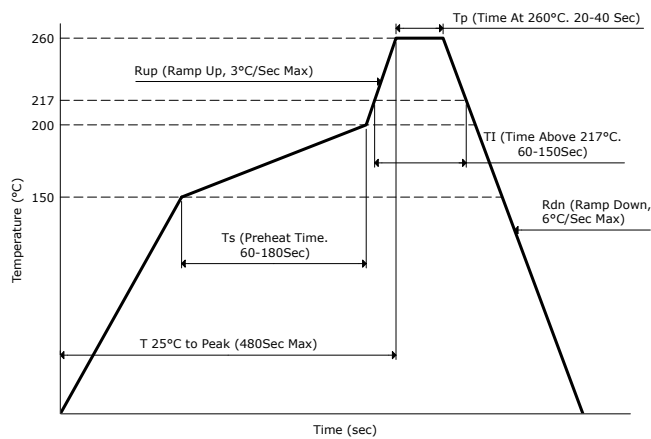

Part Marking

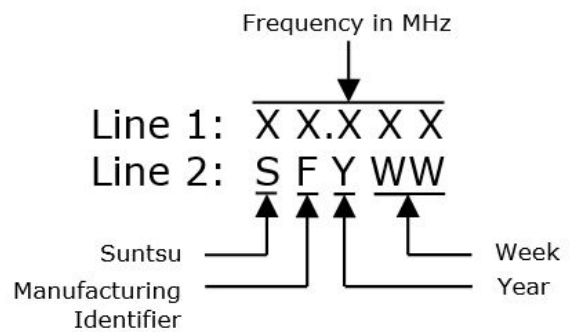

Tape And Reel Dimensions

All dimensions are in millimeters (mm) unless otherwise noted. Drawings are not to scale.

600pcs/Reel

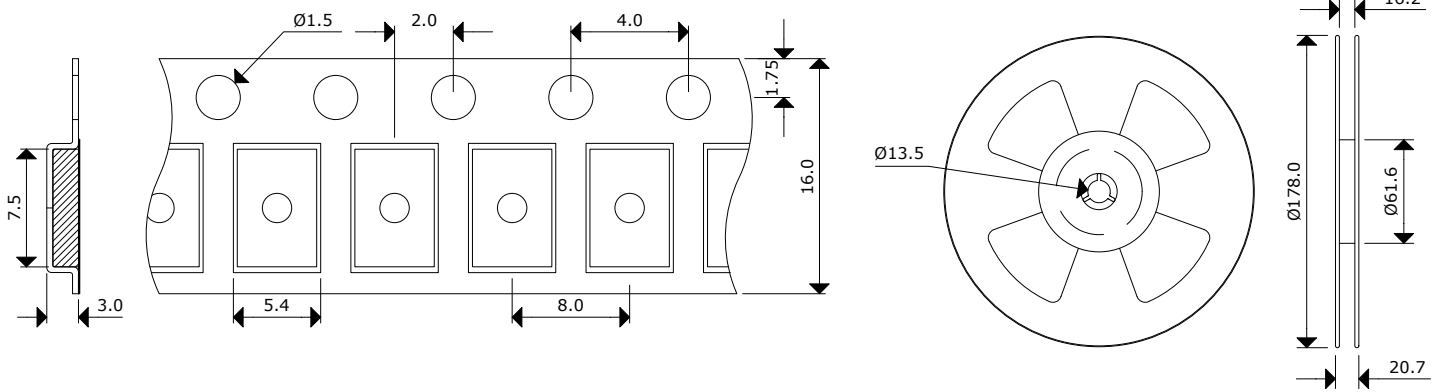

Environmental & Mechanical Specifications

Temperature Cycling	MIL-STD-883, Method 1010, Condition B	Mechanical Shock	100g;6ms; ½sine wave (directions X,Y,Z) IEC68-2-27 Test Ea/Severity 50A
Lead Integrity	MIL-STD-883, Method 2004	Resistance to Soldering	MIL-STD-202, Method 210, Condition A
Solderability	MIL-STD-883, Method 2003	Resistance to Solvents	MIL-STD-202, Method 215
Vibration	Test Condition: 0.75mm ;acceleration:10g;10Hz-2000Hz, one cycle per 30 min, test 2hrs. (3 times for each 3 directions X , Y , Z), IEC 68-2-06 Test Fc.		