

## Plug-in Signal Conditioners M-UNIT

B: 100 V / 200 V / 5 A AC (single-phase / 3- wire)

### WATT TRANSDUCER

(high-speed response)

#### Functions & Features

- Providing a DC output signal in proportion to AC active power
- Measuring bidirectional power flow
- DC output containing little ripple is ideal for computer input
- Isolation up to 2000 V AC
- High-density mounting

#### Typical Applications

- Quick countermeasure against fast and violent signal variations in power surveillance systems

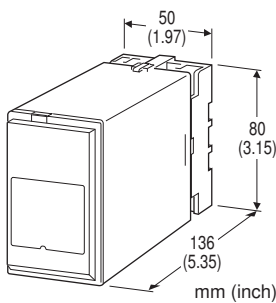

### [3] FREQUENCY

- 1: 50 Hz  
2: 60 Hz

### [4] OUTPUT

#### Current

- A: 4 - 20 mA DC (Load resistance 600 Ω max.)  
B: 2 - 10 mA DC (Load resistance 1200 Ω max.)  
C: 1 - 5 mA DC (Load resistance 2400 Ω max.)  
D: 0 - 20 mA DC (Load resistance 600 Ω max.)  
E: 0 - 16 mA DC (Load resistance 750 Ω max.)  
F: 0 - 10 mA DC (Load resistance 1200 Ω max.)  
G: 0 - 1 mA DC (Load resistance 12 kΩ max.)  
GW: -1 - +1 mA DC (Load resistance 10 kΩ max.)  
Z: Specify current (See OUTPUT SPECIFICATIONS)

#### Voltage

- 1: 0 - 10 mV DC (Load resistance 10 kΩ min.)  
2: 0 - 100 mV DC (Load resistance 100 kΩ min.)  
3: 0 - 1 V DC (Load resistance 1000 Ω min.)  
4: 0 - 10 V DC (Load resistance 10 kΩ min.)  
5: 0 - 5 V DC (Load resistance 5000 Ω min.)  
6: 1 - 5 V DC (Load resistance 5000 Ω min.)  
1W: -10 - +10 mV DC (Load resistance 10 kΩ min.)  
2W: -100 - +100 mV DC (Load resistance 100 kΩ min.)  
3W: -1 - +1 V DC (Load resistance 1000 Ω min.)  
4W: -10 - +10 V DC (Load resistance 10 kΩ min.)  
5W: -5 - +5 V DC (Load resistance 5000 Ω min.)  
0: Specify voltage (See OUTPUT SPECIFICATIONS)

## MODEL: MEWTF-[1][2][3][4]-[5][6]

### ORDERING INFORMATION

- Code number: MEWTF-[1][2][3][4]-[5][6]
- Specify a code from below for each [1] through [6].  
(e.g. MEWTF-211A-B/CE/Q)
- Calibration range (e.g. 0 - 500 W)
- VT ratio, CT ratio (e.g. VT 3300/110 V, CT 250/5 A)
- Special output range (For codes Z & 0)
- Specify the specification for option code /Q  
(e.g. /C01/S01)

### [1] CONFIGURATION

- 1: 3-phase / 3-wire (CE not available)  
2: Single-phase / 2-wire  
3: Single-phase / 3-wire (CE not available)

### [2] INPUT (unbalanced load)

- 1: 110 V / 5 A AC  
2: 110 V / 1 A AC  
3: 220 V / 1 A AC  
4: 220 V / 5 A AC  
A: 100 V / 200 V / 1 A AC (single-phase / 3- wire)

### [5] POWER INPUT

#### AC Power

- B: 100 V AC  
C: 110 V AC  
D: 115 V AC  
F: 120 V AC  
G: 200 V AC  
H: 220 V AC  
J: 240 V AC

### [6] OPTIONS (multiple selections)

#### Standards & Approvals

blank: Without CE

/CE: CE marking

(Select '2' for 'Configuration' code.)

#### Custom specification

(Refer to the custom specification list for difference of specification and combination of code numbers.)

blank: none

/X1: Input range (CE not available)

## Other Options

blank: none

/Q: Option other than the above (specify the specification)

## SPECIFICATIONS OF OPTION: Q (multiple selections)

**COATING (For the detail, refer to M-System's web site.)**

/C01: Silicone coating

/C02: Polyurethane coating

/C03: Rubber coating

## TERMINAL SCREW MATERIAL

/S01: Stainless steel

## GENERAL SPECIFICATIONS

**Construction:** Plug-in

**Connection:** M3.5 screw terminals

**Screw terminal:** Chromated steel (standard) or stainless steel

**Housing material:** Flame-resistant resin (black)

**Isolation:** Voltage input to current input to output to power

**Overrange output:** Approx. -10 to +120 % at 1 - 5 V

**Zero adjustment:** -5 to +5 % (front)

**Span adjustment:** 95 to 105 % (front)

## INPUT SPECIFICATIONS

**Frequency:** Rated frequency  $\pm 2$  Hz

### • Current Input

**Operational range:** 0 - 120 % of rating

**Overload capacity:** 1000 % of rating for 3 sec., 200 % for 10 sec., 120% continuous

### • Voltage Input

**Operational range:** 10 - 120 % of rating

**Overload capacity:** 150 % of rating for 10 sec., 120 % continuous

### ■ How To Determine Wattage Range

Calibration Range [W] = Measuring Wattage  $\div$  ((VT Ratio)  $\times$  (CT Ratio))

Check that the required calibration range is within the available range in the table. Specify this range when ordering.

[example]

3-phase / 3-wire, measuring wattage 750 kW,

VT 3300/110 V, CT 250/5 A

$750 \times 10^3$  [W]  $\div$  ((3300 $\div$ 110)  $\times$  (250 $\div$ 5)) = 0 - 500 [W]

### • 3-phase / 3-wire

VOLTAGE INPUT	CURRENT INPUT		STD RANGE	AVAILABLE RANGE	
	BURDEN	BURDEN			
110V	0.2VA $\times$ 2	1A	0.1VA $\times$ 2	$\pm 200$ W	$\pm 100$ W - $\pm 240$ W
		5A	0.5VA $\times$ 2	$\pm 1000$ W	$\pm 500$ W - $\pm 1200$ W
220V	0.4VA $\times$ 2	1A	0.1VA $\times$ 2	$\pm 400$ W	$\pm 200$ W - $\pm 480$ W
		5A	0.5VA $\times$ 2	$\pm 2000$ W	$\pm 1000$ W - $\pm 2400$ W

### • Single-phase / 2-wire

VOLTAGE INPUT	CURRENT INPUT		STD RANGE	AVAILABLE RANGE	
	BURDEN	BURDEN			
110V	0.2VA	1A	0.1VA	$\pm 100$ W	$\pm 50$ W - $\pm 120$ W
		5A	0.5VA	$\pm 500$ W	$\pm 250$ W - $\pm 600$ W
220V	0.4VA	1A	0.1VA	$\pm 200$ W	$\pm 100$ W - $\pm 240$ W
		5A	0.5VA	$\pm 1000$ W	$\pm 500$ W - $\pm 1200$ W

### • Single-phase / 3-wire

VOLTAGE INPUT	CURRENT INPUT		STD RANGE	AVAILABLE RANGE	
	BURDEN	BURDEN			
100/ 200V *1	0.2VA $\times$ 2	1A	0.1VA $\times$ 2	$\pm 200$ W	$\pm 100$ W - $\pm 240$ W
		5A	0.5VA $\times$ 2	$\pm 1000$ W	$\pm 500$ W - $\pm 1200$ W

100/200V: 100V = phase voltage

200V = line voltage except the grounding.

## OUTPUT SPECIFICATIONS

■ **DC Current:** 0 - 20 mA DC and  $\pm 1$  mA

**Minimum span:** 1 mA

**Offset:** Max. 1.5 times span

**Load resistance:** Output drive 12 V maximum; 10 V for  $[\pm]$  output

■ **DC Voltage:** -10 - +12 V DC

**Minimum span:** 5 mV

**Offset:** Max. 1.5 times span

**Load resistance:** Output drive 1 mA max. at  $\geq 0.5$  V

■ **OPERATION DIAGRAM (example)**

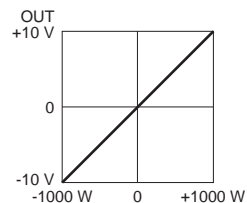
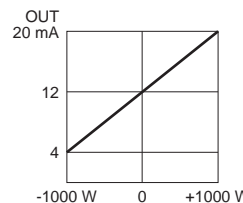
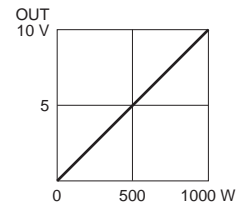
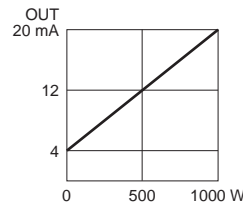

## INSTALLATION

### Power input

•AC: Operational voltage range: rating  $\pm 10\%$ ,  
50/60  $\pm 2$  Hz, approx. 3.5 VA

**Operating temperature:** -5 to +60°C (23 to 140°F)

**Operating humidity:** 30 to 90 %RH (non-condensing)

**Mounting:** Surface or DIN rail

**Weight:** 450 g (0.99 lb)

## PERFORMANCE in percentage of span

**Accuracy:**  $\pm 1.0\%$

**Temp. coefficient:**  $\pm 0.1\%/^{\circ}\text{C}$  ( $\pm 0.06\%/^{\circ}\text{F}$ )

**Response time:** Approx. 40 msec. (0 - 90 %)

**Ripple:** 1 %p-p max.

**Line voltage effect:**  $\pm 0.1\%$  over voltage range

**Insulation resistance:**  $\geq 100\text{ M}\Omega$  with 500 V DC

**Dielectric strength:** 2000 V AC @ 1 minute

(voltage input to current input to output to power to ground)

## STANDARDS & APPROVALS

### EU conformity:

EMC Directive

EMI EN 61000-6-4

EMS EN 61000-6-2

Low Voltage Directive

EN 61010-1

Measurement Category II (input)

Installation Category II (power)

Pollution Degree 2

Input to output or power: Reinforced insulation (300 V)

Output to power: Basic insulation (300 V)

RoHS Directive

EN 50581

## CONNECTION DIAGRAM

### 3-PHASE/3-WIRE

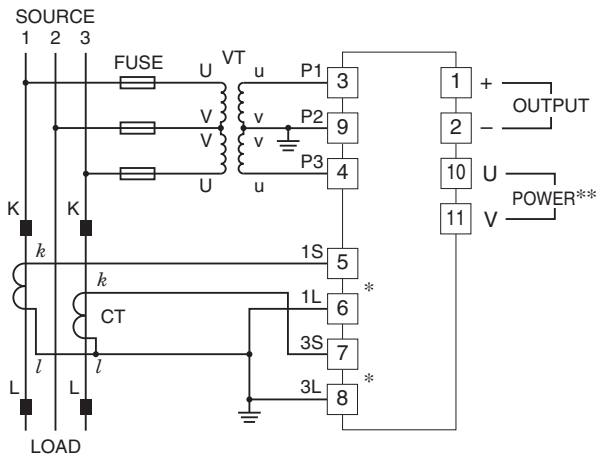

\*CT Protector (model: CTM) attached to these terminals.

### SINGLE-PHASE/2-WIRE

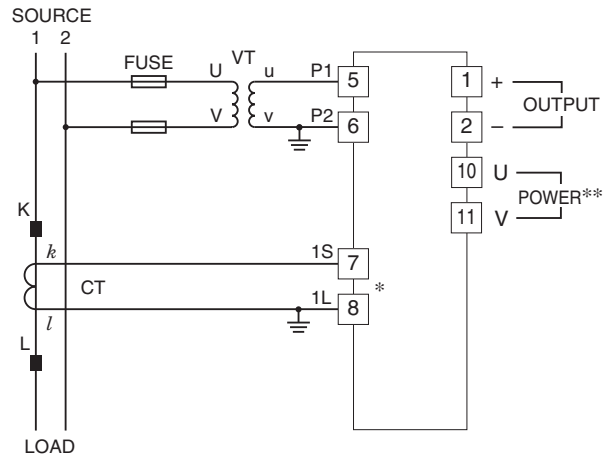

\*CT Protector (model: CTM) attached to these terminals.

### SINGLE-PHASE/3-WIRE

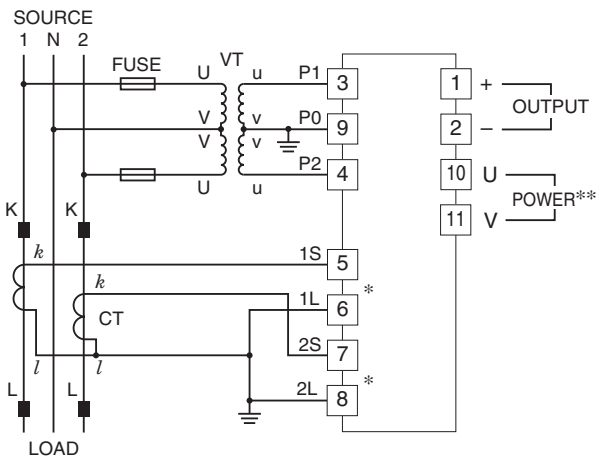

\*CT Protector (model: CTM) attached to these terminals.

\*\*The transducer can be powered from the input voltage when the voltage is sufficiently stable and meets other supply voltage requirements.

## EXTERNAL DIMENSIONS unit: mm (inch)

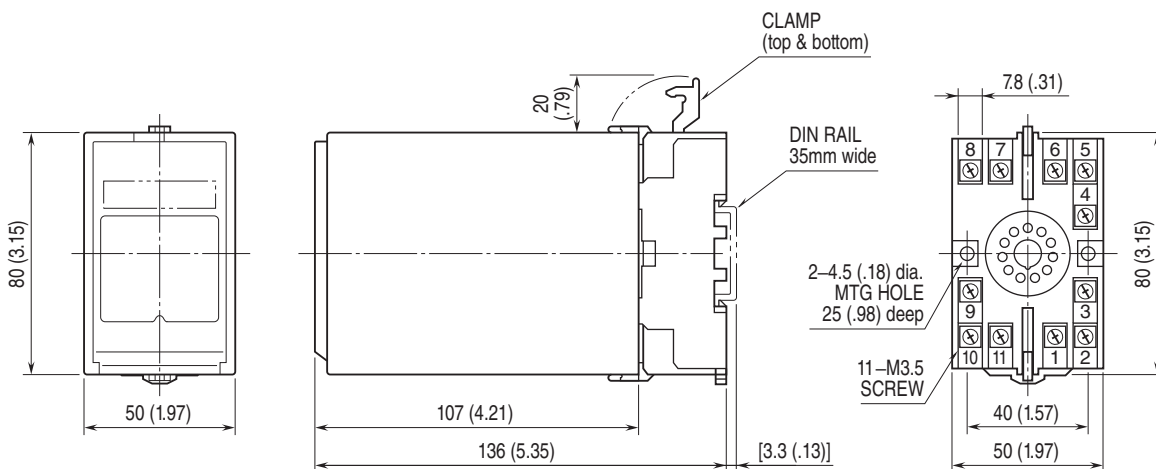

• When mounting, no extra space is needed between units.

**TERMINAL ASSIGNMENTS unit: mm (inch)**

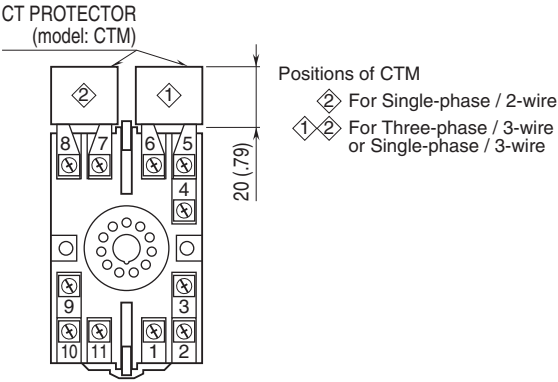

Specifications are subject to change without notice.

---

**CUSTOM SPECIFICATION LIST**

Refer to the following pages for each detailed custom specification.

**Custom specification:** Option /X1

■ Major specification changes

Input 0%: -10 - 0 % of input 100% (W)

## CUSTOM SPECIFICATION : OPTION /X1

### Major specification changes

Input 0%: -10 - 0 % of input 100% (W)

## MODEL: MEWTF-[1][2][3][4]-[5][6]

Same as standard specification (without customization) except followings.

Refer to standard specification pages.

## ORDERING INFORMATION

- Code number: MEWTF-[1][2][3][4]-[5][6]

For each [1] through [6] same code as standard specification is available.

Be sure to specify /X1 of option [6].

(e.g. MEWTF-111A-B/X1/Q)

Refer to standard specification pages.

## SPECIFICATION CHANGES

### ■ Input specifications

- Available input range

The value for 0% is within -10 - 0 % of input 100%.

e.g. Input range: -75 to 1000 [W]

$-75 [W] \div 1000 [W] \times 100 = -7.5 [\%]$

### ■ OPERATION DIAGRAM (example)

