

Features

- 1.2 INCH CHARACTER HEIGHT.
- LOW CURRENT OPERATION.
- HIGH CONTRAST AND LIGHT OUTPUT.
- EASY MOUNTING ON P.C. BOARDS OR SOCKETS.
- CATEGORIZED FOR LUMINOUS INTENSITY.
- MECHANICALLY RUGGED.
- STANDARD : GRAY FACE, WHITE SEGMENT.
- RoHS COMPLIANT.

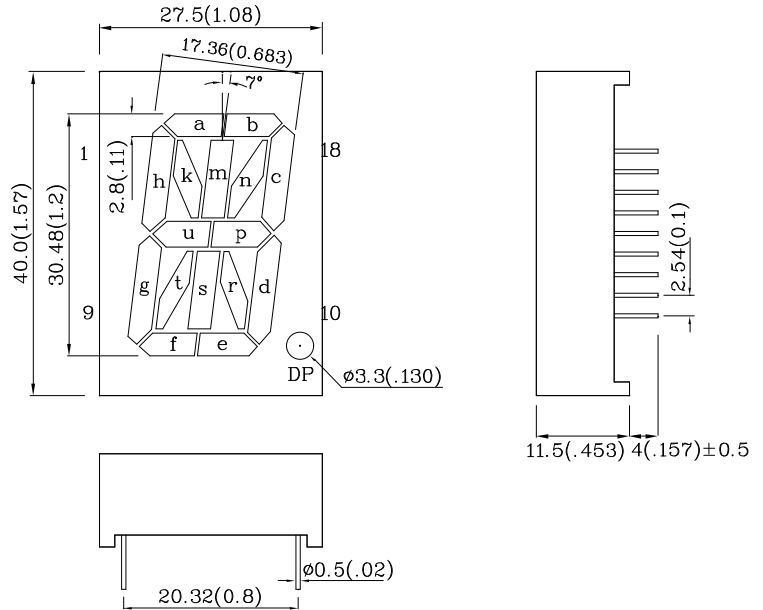
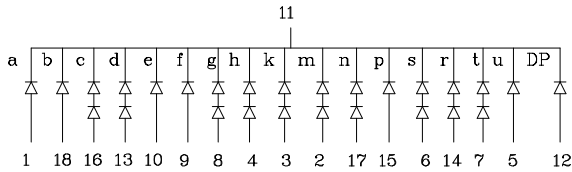

Notes:

1. All dimensions are in millimeters (inches).
2. Tolerance is $\pm 0.25(0.01)$ " unless otherwise noted.
3. Specifications are subject to change without notice.

Absolute Maximum Ratings (TA=25°C)			MR (GaAlAs)	Unit
Reverse Voltage	c,d,g,h,k,m,n, s,r,t	VR	10	V
	a,b,e,f,p,u and DP		5	
DC Forward Current	c,d,g,h,k,m,n, s,r,t	IF	30	mA
	a,b,e,f,p,u and DP			
Forward Current (Peak) 1/10 Duty Cycle 0.1ms Pulse Width	c,d,g,h,k,m,n, s,r,t	IFS	155	mA
	a,b,e,f,p,u and DP			
Power Dissipation	c,d,g,h,k,m,n, s,r,t	PT	150	mW
	a,b,e,f,p,u and DP		75	
Operating Temperature		TA	-40 ~ +85	°C
Storage Temperature		Tstg	-40 ~ +85	
Lead Solder Temperature [2mm Below Package Base]			260°C For 3~5 Seconds	

Operating Characteristics (TA=25°C)			MR (GaAlAs)	Unit
Forward Voltage (Typ.) (IF=10mA)	c,d,g,h,k,m,n, s,r,t	VF	3.6	V
	a,b,e,f,p,u and DP		1.8	
Forward Voltage (Max.) (IF=10mA)	c,d,g,h,k,m,n, s,r,t	VF	5	V
	a,b,e,f,p,u and DP		2.5	
Reverse Current (Max.) (VR=10V(5V))	c,d,g,h,k,m,n, s,r,t	IR	10	uA
	a,b,e,f,p,u and DP			
Wavelength of Peak Emission (Typ.) (IF=10mA)		λ P	660	nm
Wavelength of Dominant Emission (Typ.) (IF=10mA)		λ D	640	nm
Spectral Line Full Width At Half- Maximum (Typ.)(IF=10mA)		Δλ	20	nm
Capacitance (Typ.) (VF=0V, f=1MHz)		C	45	pF

Part Number	Emitting Color	Emitting Material	Luminous Intensity (IF=10mA) ucd		Wavelength nm λ P	Description
			min.	typ.		
AMR30C	Red	GaAlAs	8000	25990	660	Common Cathode, Rt. Hand Decimal

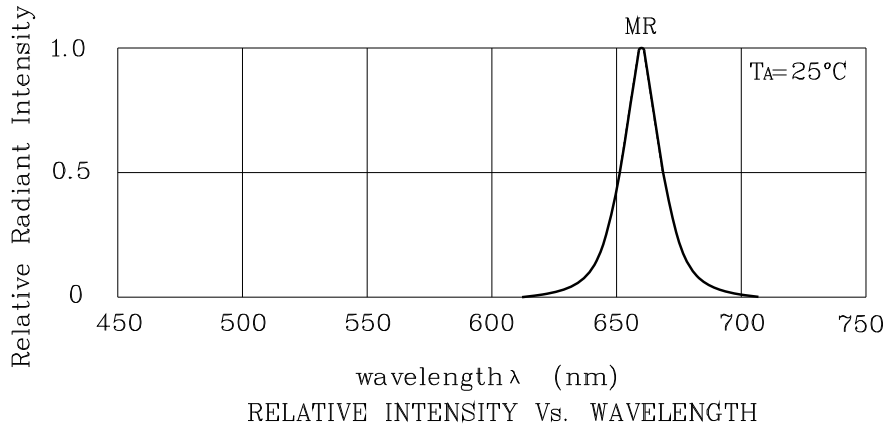

❖ MR

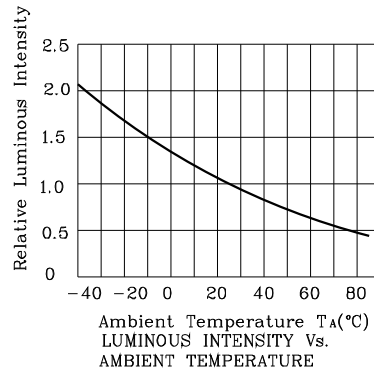
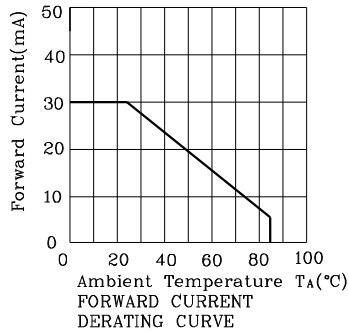
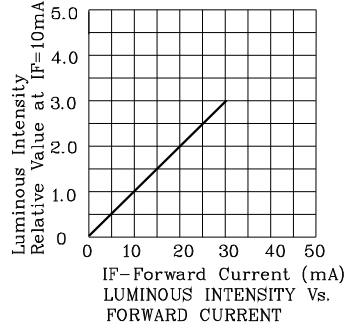
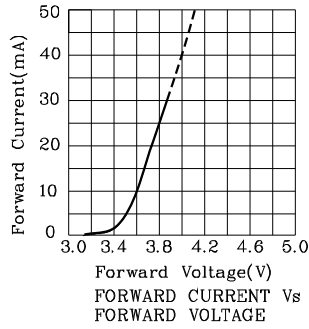

Note: the curves are on the segment c,d,g,h,k,m,n,s,r and t.

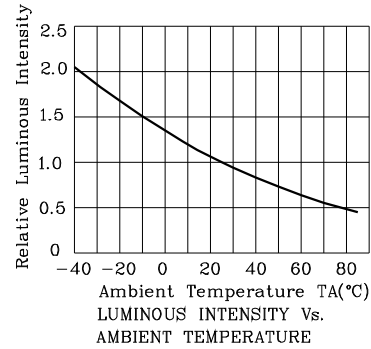
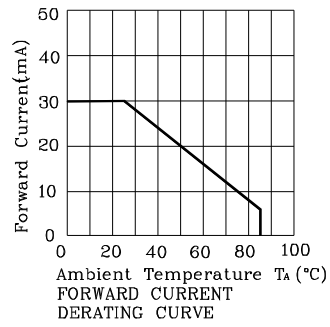
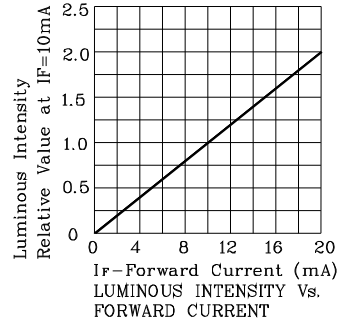
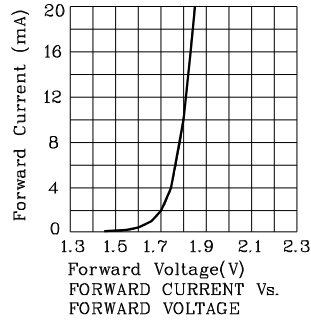

Note:the curves are on the segment a,b,e,f,p,u and DP.

Wave Soldering Profile For Lead-free Through-hole LED.

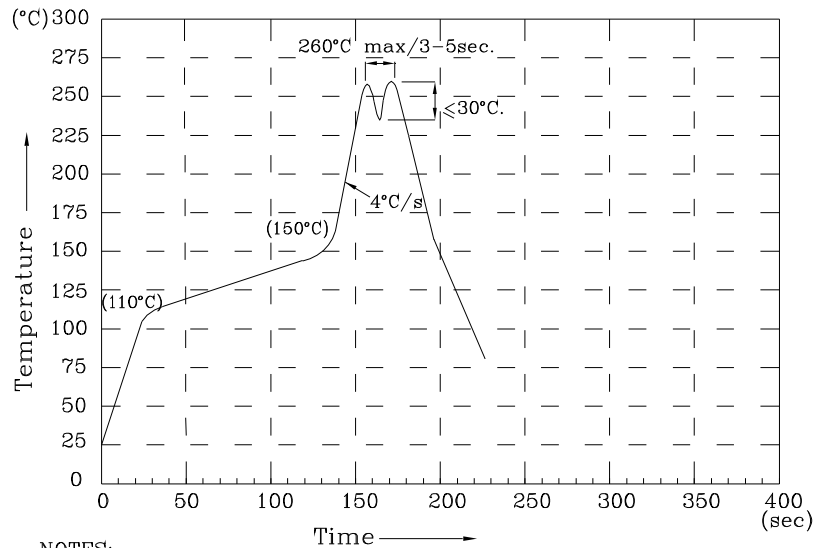

NOTES:

1. Recommend the wave temperature 245°C~260°C. The maximum soldering temperature should be less than 260°C.
2. Do not apply stress on epoxy resins when temperature is over 85 degree°C.
3. The soldering profile apply to the lead free soldering (Sn/Cu/Ag alloy).
4. No more than once.

Remarks:

If special sorting is required (e.g. binning based on forward voltage, luminous intensity / luminous flux or wavelength), the typical accuracy of the sorting process is as follows:

1. Wavelength: +/-1nm
2. Luminous Intensity / Luminous Flux: +/-15%
3. Forward Voltage: +/-0.1V

Note: Accuracy may depend on the sorting parameters.

PACKING & LABEL SPECIFICATIONS

AMR30C

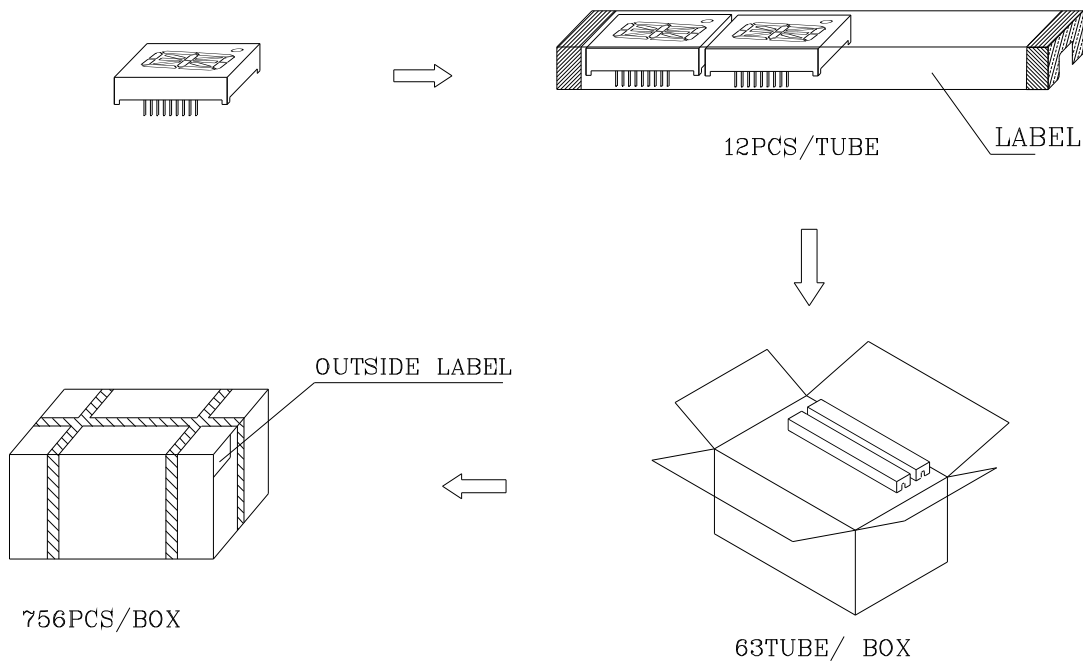

Inside LABEL Paste On The IC-tube

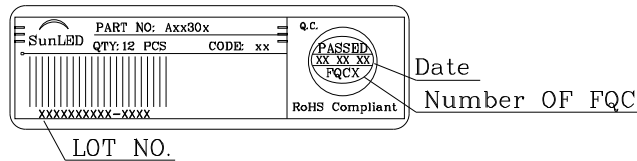

Outside LABEL Paste On The Box

