

APPROVED: _____
 DATE: _____ TITLE: _____

Rev	AWO #	Description	Date	Appr
-		RELEASED	1/26/05	

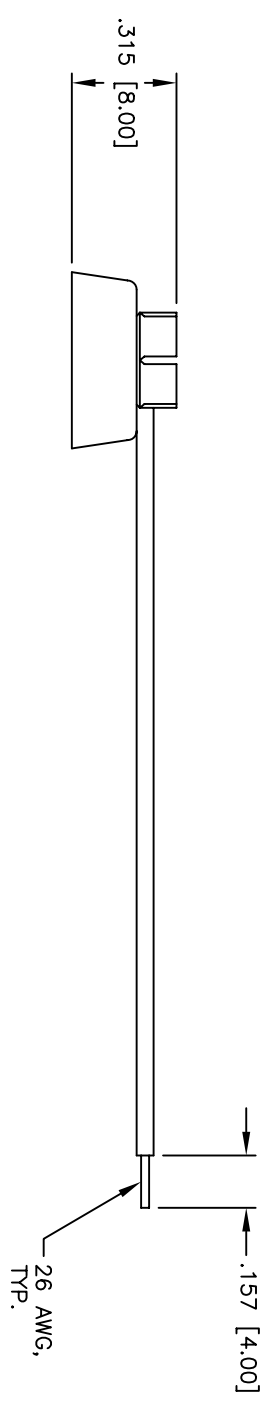

SPECIFICATIONS:
 Material: Rigid PE
 Snap terminals: Brass, Nickel plated
 Wire: 26 AWG, PVC insulation
 Electrical:
 Operating voltage: 9 VDC max.
 Temperature Rating:
 Operating temperature: -10°C to +180°C
 Environmental:
 Lead free, RoHS compliant

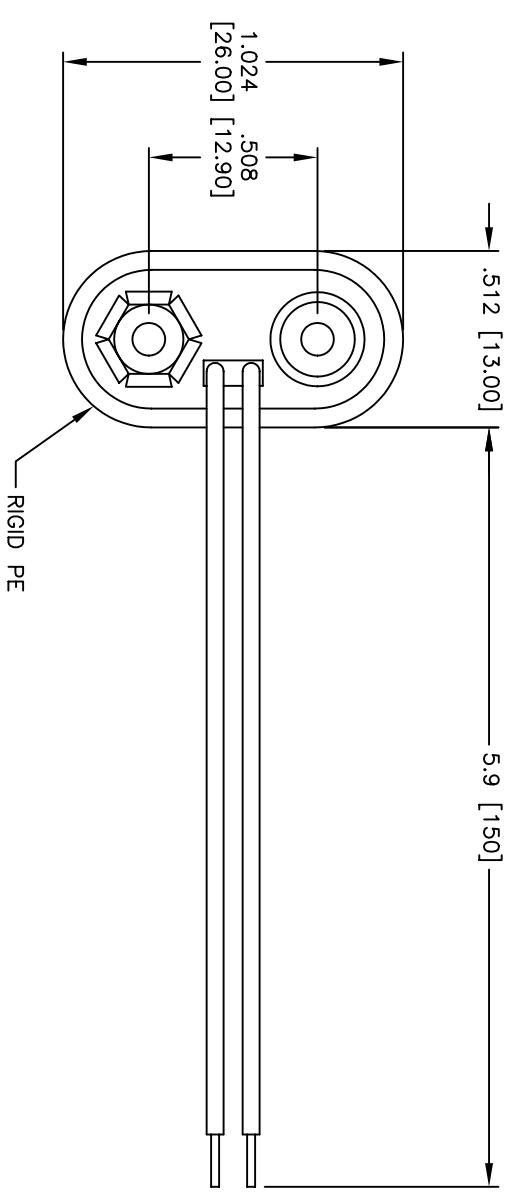

UNLESS OTHERWISE SPECIFIED
 ALL DIMENSIONS ARE INCHES [MM]
 TOLERANCES: EXCEPT AS NOTED
 INCHES HOLES
 .X ±.10 ØX ±.10
 .XX ±.020 ØXX ±.015
 .XXX ±.015 ØXXX ±.010

ADAM TECH
 909 Rahway Avenue, Union, NJ 07083
 Phone: 908-687-5000 Fax: 908-687-5710

APPROVALS		DATE		TITLE	
DRAWN	SS		1/26/05	BATTERY SNAP, STANDARD LENGTH LEADS	
CHECKED				SIZE	PART NO.
APPROVED				X	BS-6-1
		REF:	SCALE: NTS	SHEET	1 OF 1

6 5 4 3 2 1