



U74AHC1G132

CMOS IC

SINGLE 2-INPUT NAND GATE WITH SCHMITT-TRIGGER INPUTS

DESCRIPTION

The **U74AHC1G132** contains one 2-input NAND gate with Schmitt-trigger inputs designed for 2V to 5.5V V_{CC} operation and performs the Boolean function $Y = \overline{A \cdot B}$ or $Y = \overline{A} + \overline{B}$ in positive logic.

Because of Schmitt action, this device has different input threshold levels for positive-going (V_{T+}) and negative-going (V_{T-}) signals.

This device can be triggered from the slowest of input ramps and still give clean jitter-free output signals.

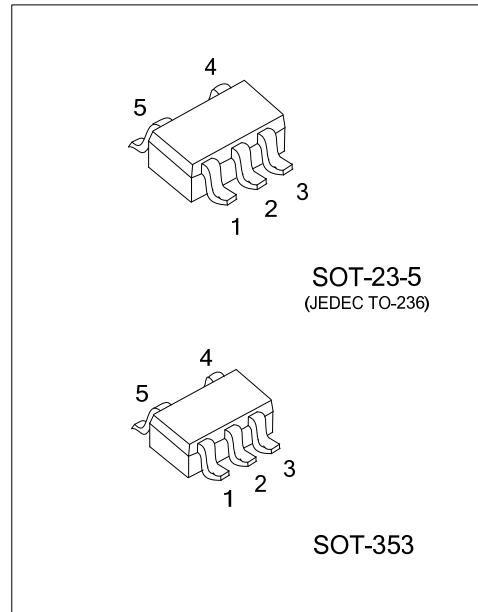

FEATURES

- * Operation voltage range: 2 ~ 5.5V
- * Max t_{pd} of 7.7 ns at 5 V
- * Low static power consumption; $I_{CC}=2\mu A$ (Max.)
- * $\pm 8mA$ output drive at 5 V

ORDERING INFORMATION

Ordering Number	Package	Packing
U74AHC1G132G-AE5-R	SOT-23-5	Tape Reel
U74AHC1G132G-AL5-R	SOT-353	Tape Reel

<p>U74AHC1G132G-AE5-R</p> <ul style="list-style-type: none"> (1) Packing Type (2) Package Type (3) Green Package 	<ul style="list-style-type: none"> (1) R: Tape Reel (2) AE5: SOT-23-5, AL5: SOT-353 (3) G: Halogen Free and Lead Free
---	--

MARKING

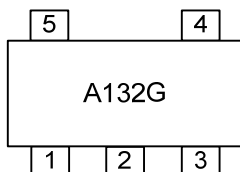

■ PIN CONFIGURATION

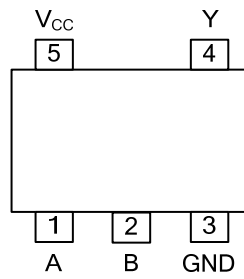

■ FUNCTION TABLE (each gate)

INPUTS		OUTPUT
A	B	Y
H	H	L
L	X	H
X	L	H

■ LOGIC DIAGRAM (positive logic)

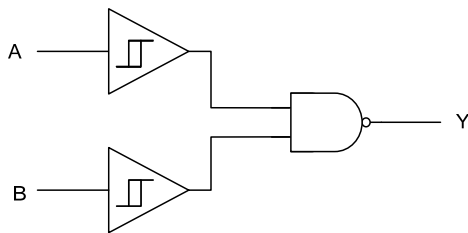

■ ABSOLUTE MAXIMUM RATING

PARAMETER	SYMBOL	CONDITIONS	RATINGS	UNIT
Supply Voltage	V_{CC}		-0.5 ~ +7.0	V
Input Voltage	V_{IN}		-0.5 ~ +7.0	V
Output Voltage	V_{OUT}		-0.5 ~ $V_{CC} + 0.5$	V
Continuous V_{CC} or GND Current	I_{CC}		±50	mA
Continuous Output Current	I_{OUT}	$V_{OUT}=0 \sim V_{CC}$	±25	mA
Input Clamp Current	I_{IK}	$V_{IN} < 0$	-20	mA
Output Clamp Current	I_{OK}	$V_{OUT} < 0$ or $V_{OUT} > V_{CC}$	±20	mA
Operating Temperature	T_{OPR}		-40 ~ + 85	°C
Storage Temperature Range	T_{STG}		-65 ~ + 150	°C

Notes: 1. Absolute maximum ratings are those values beyond which the device could be permanently damaged. Absolute maximum ratings are stress ratings only and functional device operation is not implied.
 2. The input and output voltage ratings may be exceeded if the input and output current ratings are observed.

■ RECOMMENDED OPERATING CONDITIONS

PARAMETER	SYMBOL	TEST CONDITIONS	MIN	TYP	MAX	UNIT
Supply Voltage	V_{CC}	Operating	2.0	5.0	5.5	V
Input Voltage	V_{IN}		0		5.5	V
Output Voltage	V_{OUT}	High or low state	0		V_{CC}	V
Operating Temperature	T_A		-40		+85	°C
Input Transition Rise or Fall Rate	$\Delta t/\Delta v$	$V_{CC}=3.3 \pm 0.3V$			100	ns/V
		$V_{CC}=5.0 \pm 0.5V$			20	ns/V

■ ELECTRICAL CHARACTERISTICS ($T_A = 25^\circ C$, unless otherwise specified)

PARAMETER	SYMBOL	TEST CONDITIONS	MIN	TYP	MAX	UNIT
Positive-going input threshold voltage	V_{T+}	$V_{CC}=3.0V$	1.2		2.2	V
		$V_{CC}=4.5V$	1.75		3.15	
		$V_{CC}=5.5V$	2.15		3.85	
Negative-going input threshold voltage	V_{T-}	$V_{CC}=3.0V$	0.9		1.9	V
		$V_{CC}=4.5V$	1.35		2.75	
		$V_{CC}=5.5V$	1.65		3.35	
Hysteresis ($V_{T+} - V_{T-}$)	ΔV_T	$V_{CC}=3V$	0.3		1.2	V
		$V_{CC}=4.5V$	0.4		1.4	
		$V_{CC}=5.5V$	0.5		1.6	
High-Level Output Voltage	V_{OH}	$V_{CC}=2.0V$	$I_{OH}=-50\mu A$	1.9	2.0	V
		$V_{CC}=3.0V$		2.9	3.0	
		$V_{CC}=4.5V$		4.4	4.5	
		$V_{CC}=3.0V, I_{OL}=-4mA$	2.58			
		$V_{CC}=4.5V, I_{OL}=-8mA$	3.94			
Low-Level Output Voltage	V_{OL}	$V_{CC}=2.0V$	$I_{OH}=-50\mu A$		0.1	V
		$V_{CC}=3.0V$			0.1	
		$V_{CC}=4.5V$			0.1	
		$V_{CC}=3.0V, I_{OL}=-4mA$		0.36		
		$V_{CC}=4.5V, I_{OL}=-8mA$		0.36		
Input Leakage Current	$I_{(LEAK)}$	$V_{CC}=0V \sim 5.5V, V_{IN}=5.5V$ or GND			±0.1	μA
Quiescent Supply Current	I_{CC}	$V_{CC}=5.0V, V_{IN}=V_{CC}$ or GND, $I_{OUT}=0$			2	μA
Input Capacitance	C_I	$V_{CC}=5.0V, V_{IN}=V_{CC}$ or GND		2	10	pF

■ SWITCHING CHARACTERISTICS ($T_A = 25^\circ\text{C}$, unless otherwise specified) (see Figure 1)

PARAMETER	SYMBOL	TEST CONDITIONS	MIN	TYP	MAX	UNIT	
Propagation delay from input (A or B) to output(Y)	t_{PLH}/t_{PHL}	$V_{CC}=3.0V\pm 3.6V$	$C_L=15pF$		5.6	11.9	ns
			$C_L=50pF$		7.6	15.4	
		$V_{CC}=4.5V\pm 5.5V$	$C_L=15pF$		3.9	7.7	ns
			$C_L=50pF$		5.3	9.7	

■ OPERATING CHARACTERISTICS ($T_A = 25^\circ\text{C}$, unless otherwise specified)

PARAMETER	SYMBOL	TEST CONDITIONS	MIN	TYP	MAX	UNIT
Power Dissipation Capacitance	C_{PD}	$V_{CC}=5.0V$, $f=1\text{MHZ}$, No load.		11		pF

■ TEST CIRCUIT AND WAVEFORMS

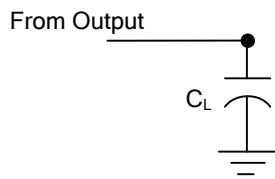

TEST CIRCUIT

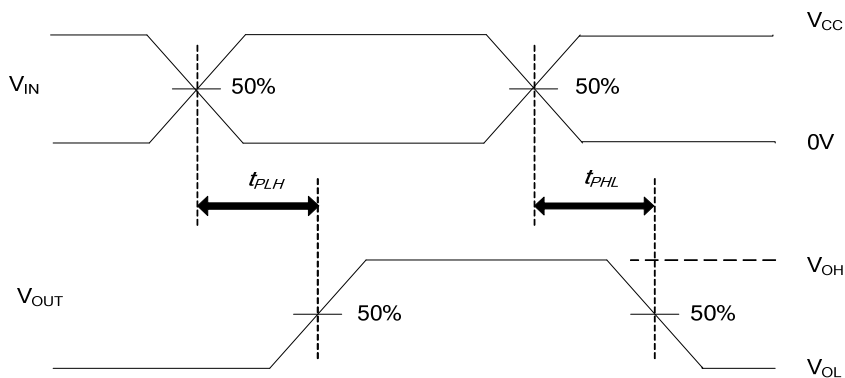

PROPAGATION DELAY TIMES

- Notes: 1. C_L includes probe and jig capacitance.
 2. All input pulses are supplied by generators having the following characteristics: PRR $\leq 1\text{MHz}$, $Z_o = 50\Omega$, $t_r \leq 3\text{ns}$, $t_f \leq 3\text{ns}$.

UTC assumes no responsibility for equipment failures that result from using products at values that exceed, even momentarily, rated values (such as maximum ratings, operating condition ranges, or other parameters) listed in products specifications of any and all UTC products described or contained herein. UTC products are not designed for use in life support appliances, devices or systems where malfunction of these products can be reasonably expected to result in personal injury. Reproduction in whole or in part is prohibited without the prior written consent of the copyright owner. The information presented in this document does not form part of any quotation or contract, is believed to be accurate and reliable and may be changed without notice.