

Customer Information Sheet

DRAWING No.: D3081-XX

SHEET 2 OF 2

IF IN DOUBT - ASK

©

NOT TO SCALE

THIRD ANGLE PROJECTION

ALL DIMENSIONS IN mm

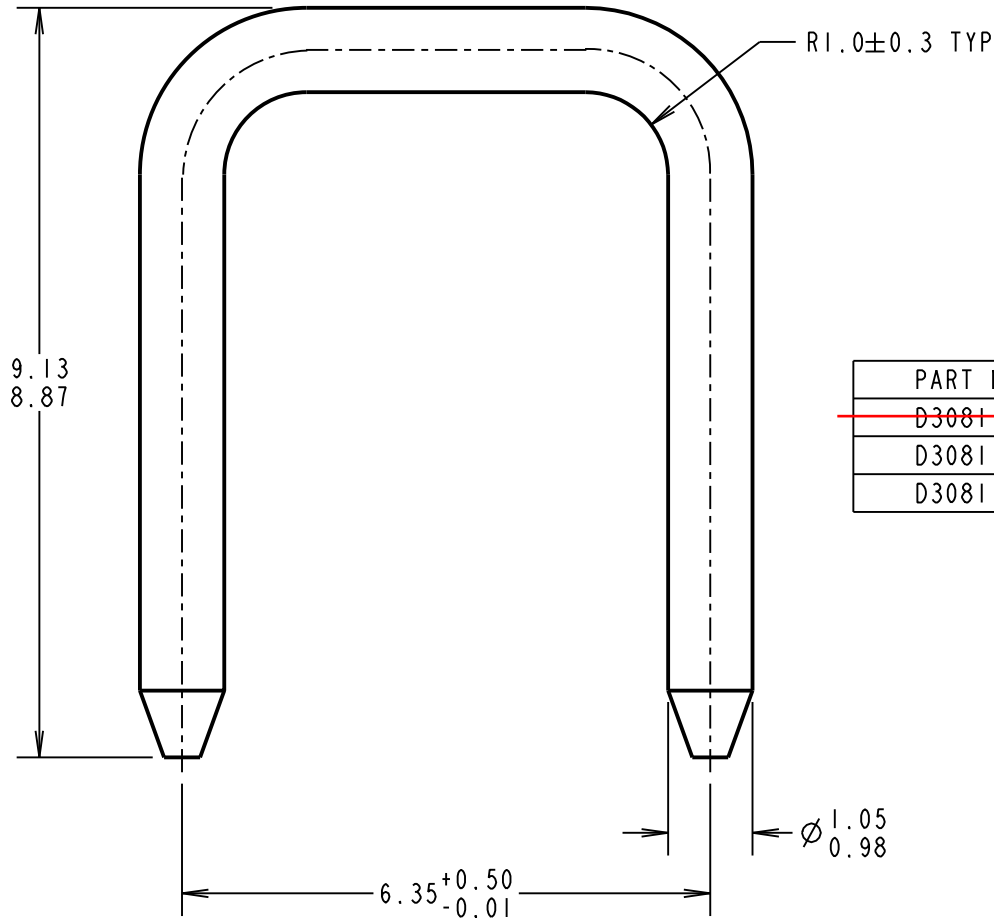

ORDER CODE:

D3081-XX

FINISH:

OBSOLETE

~~01 = 100% MATTE TIN~~
05 = GOLD FLASH
46 = 100% BRIGHT TIN

| PART No. | FINISH |
|---------------------|---|
| D3081-01 | 2.54μ 100% MATTE TIN OVER 0.76μ NICKEL UNDERCOAT |
| D3081-05 | GOLD FLASH OVER 0.76μ NICKEL UNDERCOAT |
| D3081-46 | 2.54μ 100% BRIGHT TIN OVER 0.76μ NICKEL UNDERCOAT |

| | | | |
|----------------|------|------------|--------|
| SB | 11 | 18.12.12 | 11891 |
| NAME | ISS. | DATE | C/NOTE |
| APPROVED: | | S. BENNETT | |
| CHECKED: | | S. FLOWER | |
| DRAWN: | | C. HANSEN | |
| CUSTOMER REF.: | | | |
| ASSEMBLY DRG: | | | |
| D3087-XX | | | |

HARWIN

www.harwin.com
technical@harwin.com

THIS DRAWING AND ANY INFORMATION OR DESCRIPTIVE MATTER SET OUT HEREON ARE CONFIDENTIAL AND COPYRIGHT PROPERTY OF THE HARWIN GROUP AND MUST NOT BE DISCLOSED, LOANED, COPIED OR USED FOR MANUFACTURING, TENDERING OR FOR ANY OTHER PURPOSE WITHOUT THEIR WRITTEN PERMISSION.

TOLERANCES

X. = ±1mm
X.X = ±0.25mm
X.XX = ±0.10mm
X.XXX = ±0.01mm
ANGLES = ±5°
UNLESS STATED

MATERIAL:

BRASS C2600

FINISH: SEE ABOVE

S/AREA: mm²

TITLE:

1mm SHORTING LINK

DRAWING NUMBER:

D3081-XX

SHT
2
OF
2