

Features
<ul style="list-style-type: none"> <li>• <math>\pm 20</math>ppm (Frequency Stability) Available</li> <li>• Ceramic Package</li> <li>• CMOS</li> <li>• Tape and Reel</li> </ul>

Applications
<ul style="list-style-type: none"> <li>• Mobile Communication</li> <li>• Portable Electronics</li> <li>• PDA</li> </ul>

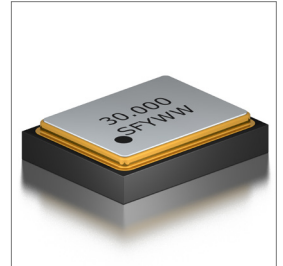

**Part Numbering Guide**

**SXO 11 C 3 A 48 1 - 30.000M**

SUNTSU OSC

1.6mm x 1.2mm

CMOS

SUPPLY VOLTAGE

1 : 1.8V $\pm$ 5%

2 : 2.5V $\pm$ 5%

3 : 3.3V $\pm$ 5%

**FREQUENCY STABILITY**

A :  $\pm 50$ ppm

B :  $\pm 30$ ppm

C :  $\pm 25$ ppm

\*D :  $\pm 20$ ppm

**FREQUENCY**  
MHz

TRI-STATE  
(ENABLE/DISABLE)  
BLANK : No Connection  
1 : Pin 1

**OPERATING TEMPERATURE RANGE**

07 : 0°C - +70°C

16 : -10°C - +60°C

17 : -10°C - +70°C

27 : -20°C - +70°C

38 : -30°C - +85°C

48 : -40°C - +85°C

Cage Code : 4GUT4

To customize your parameters, contact a Suntsu representative.

\* For Frequency stability option D, contact a Suntsu representative.

Electrical Parameters	Units	Minimum	Typical	Maximum	Remarks
Frequency Range	MHz	1		133	
Frequency Stability (Includes Initial Tolerance at 25°C, Frequency Stability over Operating Temperature, Output Load Change, Supply Voltage Change, and First Year Aging at 25°C.)	ppm	-20		+20	See part numbering guide for options
Operating Temperature	°C	-40		+85	See part numbering guide for options
Storage Temperature	°C	-55		+125	
Supply Voltage (V <sub>DD</sub> ) - 1.8V option	V	1.710	1.8	1.890	
Supply Voltage (V <sub>DD</sub> ) - 2.5V option	V	2.375	2.5	2.625	
Supply Voltage (V <sub>DD</sub> ) - 3.3V option	V	3.135	3.3	3.465	
Current (I <sub>DD</sub> )	mA			10	
Output Load (CMOS)	pF			15	
Output Logic Levels High (V <sub>OH</sub> )	V	V <sub>DD</sub> -0.4			
Output Logic Levels Low (V <sub>OL</sub> )	V			V <sub>DD</sub> +0.4	
Rise (TR) and Fall (TF) Time	ns			4.5	
Symmetry (Duty Cycle)	%	45	50	55	
Tri-State Input Voltage - Enable	V	0.7*V <sub>DD</sub>			No Connection
Tri-State Input Voltage - Disable	V			0.3*V <sub>DD</sub>	
Start-Up Time	ms			5.0	
Phase Jitter (12kHz ~ 20MHz)	ps			1	

**Outline Drawing & Land Pattern**

All dimensions are in millimeters (mm) unless otherwise noted. Drawings are not to scale.

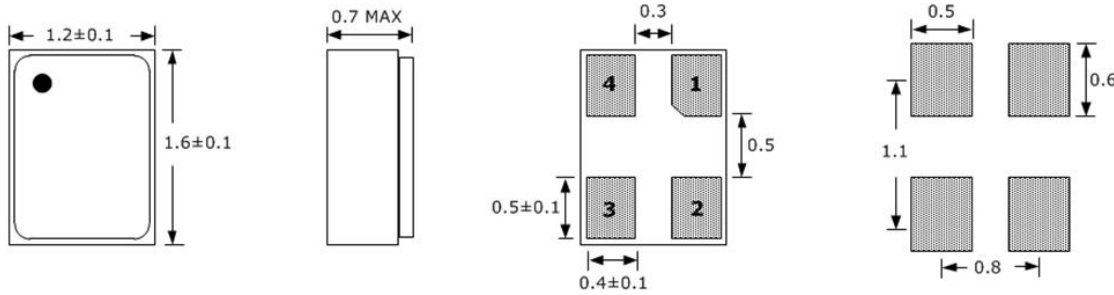

PIN	FUNCTION
1	TRI-STATE or NC
2	GND
3	OUTPUT
4	V <sub>DD</sub>

**Test Circuit (CMOS)**

**Waveform (CMOS)**

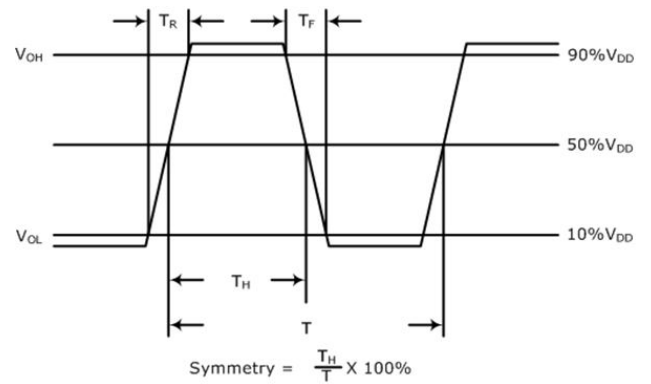
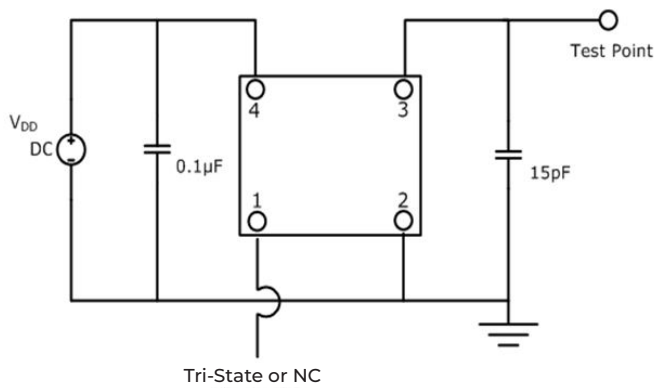

**Typical Phase Noise Performance (Measured By Agilent E5052A)**

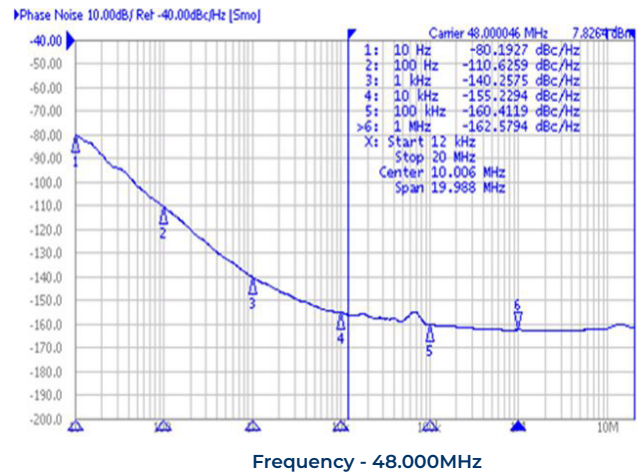
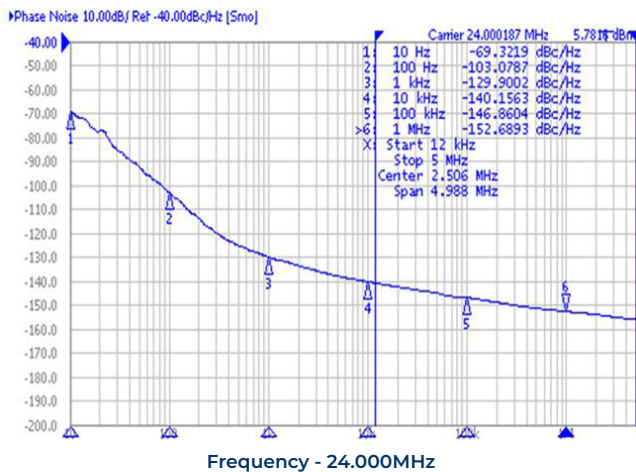

### Typical Jitter Performance (Measured By Agilent E5052A)

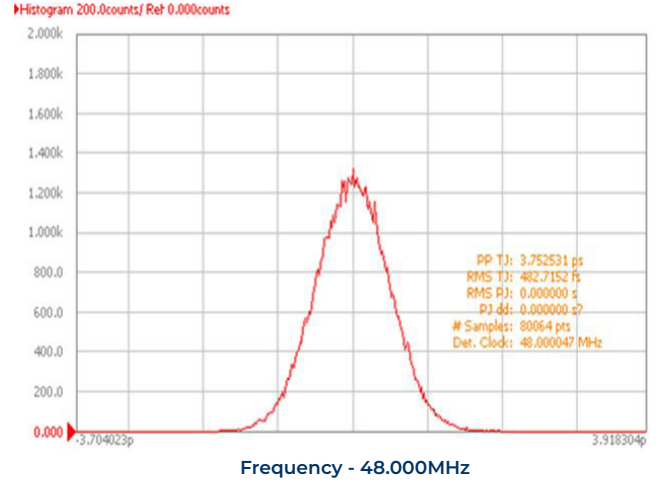
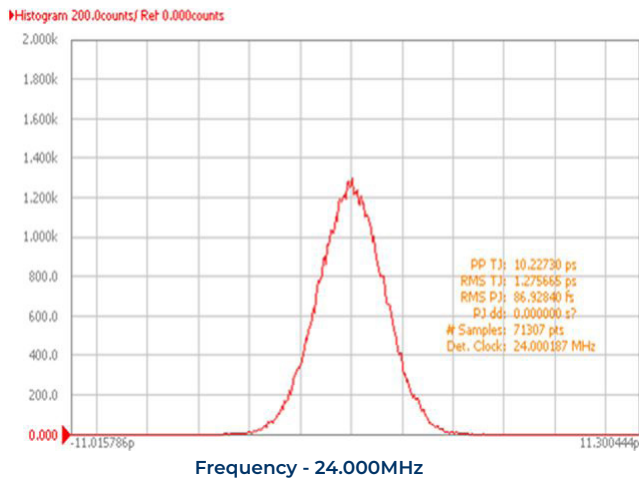

### Reflow Profile

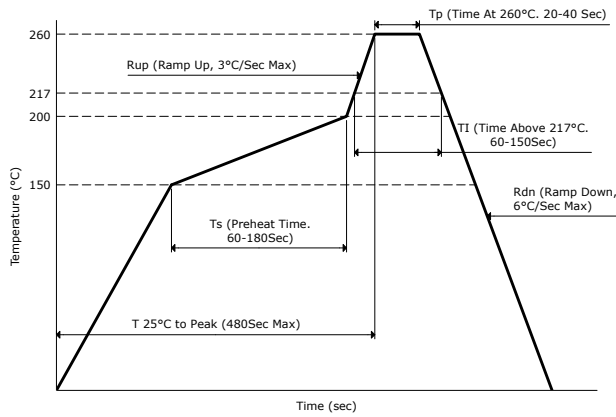

### Part Marking

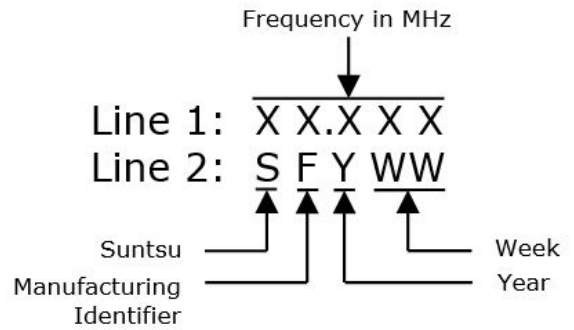

### Tape And Reel Dimensions

All dimensions are in millimeters (mm) unless otherwise noted. Drawings are not to scale.

3,000pcs/Reel

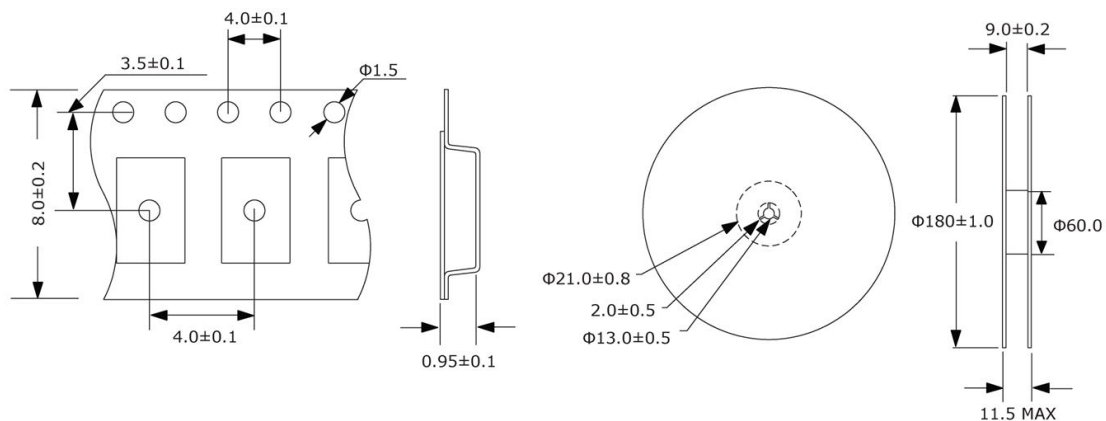

Environmental Specifications		Mechanical Specifications	
Temperature Cycling	MIL-STD-883, Method 1010, Condition B	Mechanical Shock	MIL-STD-202, Method 213, Condition B
Fine Leak Test	MIL-STD-883, Method 1014, Condition A	Vibration	MIL-STD-883, Method 2007, Condition A
Gross Leak Test	MIL-STD-883, Method 1014, Condition C	Moisture Resistance	MIL-STD-883, Method 1004
Solderability	MIL-STD-883, Method 2003	Resistance to Solvents	MIL-STD-202, Method 215
Moisture Sensitivity	J-STD-020, MSL 1	Resistance to Soldering Heat	MIL-STD-202, Method 210, Condition K