

| | | | |
|-----|-------|-----|-----|
| DR. | J.L.P | CH. | AP. |
| DR. | | CH. | AP. |

| | |
|------------|-----------------------|
| REV. 1. ▽ | 95 WAS 100 |
| REV. 2. ▽▽ | 1 1/2X1-6 MODEL Added |

O-K
OVERALL DIMENSIONAL DRAWING

CUSTOMER:
ORDER NO.
JOB/PROJECT:

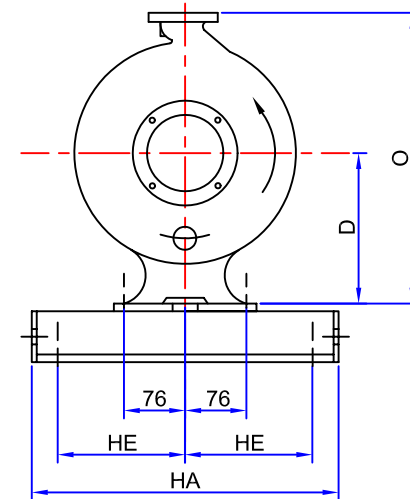
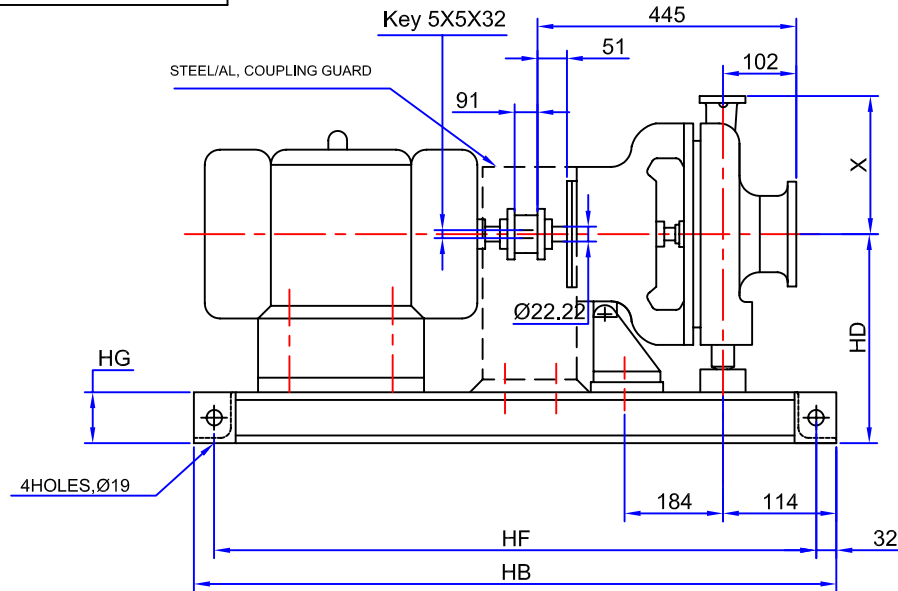

| FLANGE DETAIL : ASME B 16.5#150 FF/RF | | | | | | | | | | | | X | O | D | PUMP (Approx) Wt. Kgs. | |
|---------------------------------------|---------|------|------|------|--------|-----|-----------|------|------|------|--------|-----|-----|-------|------------------------------|----|
| MODEL | SUCTION | | | | | | DISCHARGE | | | | | | | | | |
| | OD | Bore | PCD | Thk | Hole Ø | No. | OD | Bore | PCD | Thk | Hole Ø | No. | | | | |
| 1 1/2X1-5 | 127 | 41.3 | 98.4 | 14.5 | 16 | 4 | 108 | 27 | 79.4 | 11.5 | 16 | 4 | 165 | 298.5 | 133.5 | 32 |
| 1 1/2X1-6 | 127 | 41.3 | 98.4 | 14.5 | 16 | 4 | 108 | 25 | 79.4 | 11.5 | 16 | 4 | 165 | 298.5 | 133.5 | 36 |

| Bp. No. | Motor Frame | ★ Cplg | Baseplate Mounting Dimensions | | | | | | Wt.⊙ Approx (Kg) |
|------------|----------------|-----------|-------------------------------|-----|-------|------|-----|-----|------------------------|
| | | | HA | HB | HD* | HE | HF | HG* | |
| 110 | 71 to 100L | 095 | 250 | 890 | 213.5 | 95 ▽ | 826 | 80 | 27 |
| | 112M | 100 | | | | | | | |

★ CPLG. SELECTED AS PER 2900 RPM
FOUNDATION BOLT SIZE & LENGTH - M16 x 250
★ BASEPLATE PLUS RAISE BLOCK WEIGHT
⊙ MAY BE EXCEEDED BY 10mm, BUT NEVER BE LESS
THAN DIMENSION SHOWN.
ALL DIMENSIONS ARE IN mm. (Approx.)

| REV. | | | |
|------|---|---|--|
| 0 | 1 | 2 | |

| |
|-------------------|
| DRG NO.: P-O-K-02 |
| OUR Ref. |

MICROFINISH PUMPS
PVT. LTD. 