

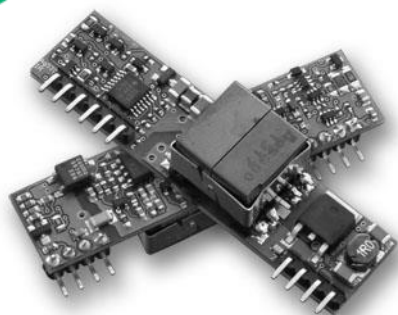

Ag5300

Power-over-Ethernet Plus Module



1 Features

- IEEE802.3at and IEEE802.3af compliant
- Maximum 30W peak output power*
- Small Single In-Line (SIL) package size –57.3mm (L) x 14mm (H)
- Overload, short-circuit and thermal protection
- Adjustable output voltage
- Minimal (low cost) external components
- Low output ripple & noise
- High efficiency DC/DC converter
- 1500Vdc isolation (input to output)
- Silvertel “design-in” assistance

2 Description

The Ag5300** Power-over-Ethernet (PoE+) module is designed to extract power from a conventional twisted pair Category 5 Ethernet cable, conforming to the IEEE 802.3at PoE standard.

The Ag5300 has been designed to extract power from Power Sourcing Equipment (PSE) over a conventional twisted pair Category 5 Ethernet cable. The module input conforms to the IEEE803.2at standard for signature recognition and class programming.

The high efficiency DC/DC converter operates over a wide input voltage range with a low ripple and low noise output. The DC/DC converter also has built-in output overload, output short-circuit and over-temperature protection and provides a 1500Vdc (input to output) isolation barrier.

*For Ag5300 and Ag5324 only.

**All references to the Ag5300 also apply to the AG5305 and Ag5324

Table of Contents

1	Features	1
2	Description.....	1
	Table of Contents	2
	Table of Figures	2
3	Ag5300 Product Selector [†]	3
4	Pin Description	4
5	Functional Description	5
5.1	Inputs.....	5
5.2	PD Signature	5
5.3	Isolation	6
5.4	Power Classification	6
5.5	AT Detection.....	6
5.6	DC/DC Converter	7
5.7	Output Adjustment.....	8
5.8	Typical Connections	9
5.9	Minimum Load.....	10
5.10	Output Power.....	10
6	Typical Application.....	10
7	Layout Consideration.....	11
8	Operating Temperature Range	12
9	Protection	15
9.1	ESD.....	15
10	EMC	16
11	Electrical Characteristics	17
11.1	Absolute Maximum Ratings*	17
11.2	Recommended Operating Conditions.....	17
11.3	DC Electrical Characteristics*	17
12	Package	18
12.1	Plan View	19

Table of Figures

Figure 1:	Block Diagram	3
Figure 2:	Ag5300 SIL Package Format.....	4
Figure 3:	Typical System Diagram	5
Figure 4:	Two Event Physical Layer Detect Configuration	6
Figure 5:	Output Adjustment	8
Figure 6:	Typical PoE Only Connection Diagram.....	9
Figure 7:	Typical Application.....	11
Figure 8:	Layout Consideration	11
Figure 9:	Ag5305 Operating Profile	12
Figure 10:	Ag5300 Operating Profile	13
Figure 11:	Ag5324 Operating Profile	13
Figure 12:	Thermal Relief Power Planes	14
Figure 13:	Input Protection.....	15
Figure 14:	EMC Filtering.....	16

3 Ag5300 Product Selector[†]

Part Number	Nominal Output Voltage	Maximum Output Power *	Marking	Package
Ag5305	5V	22.5 Watts Peak 20 Watts Continuous	5	SIL
Ag5300	12V	30 Watts Peak 24 Watts Continuous		SIL
Ag5324	24V	30 Watts Peak 24 Watts Continuous		SIL

*At 25°C with $V_{IN} = 52V$

[†] RoHS Statement - The Ag5300 range complies with the European Directive 2011/65/EU for the Restriction of use of certain Hazardous Substances (RoHS) including Directive 2015/863 published in 2015, amending Annex II of Directive 2011/65/EU.

Table 1: Ordering Information

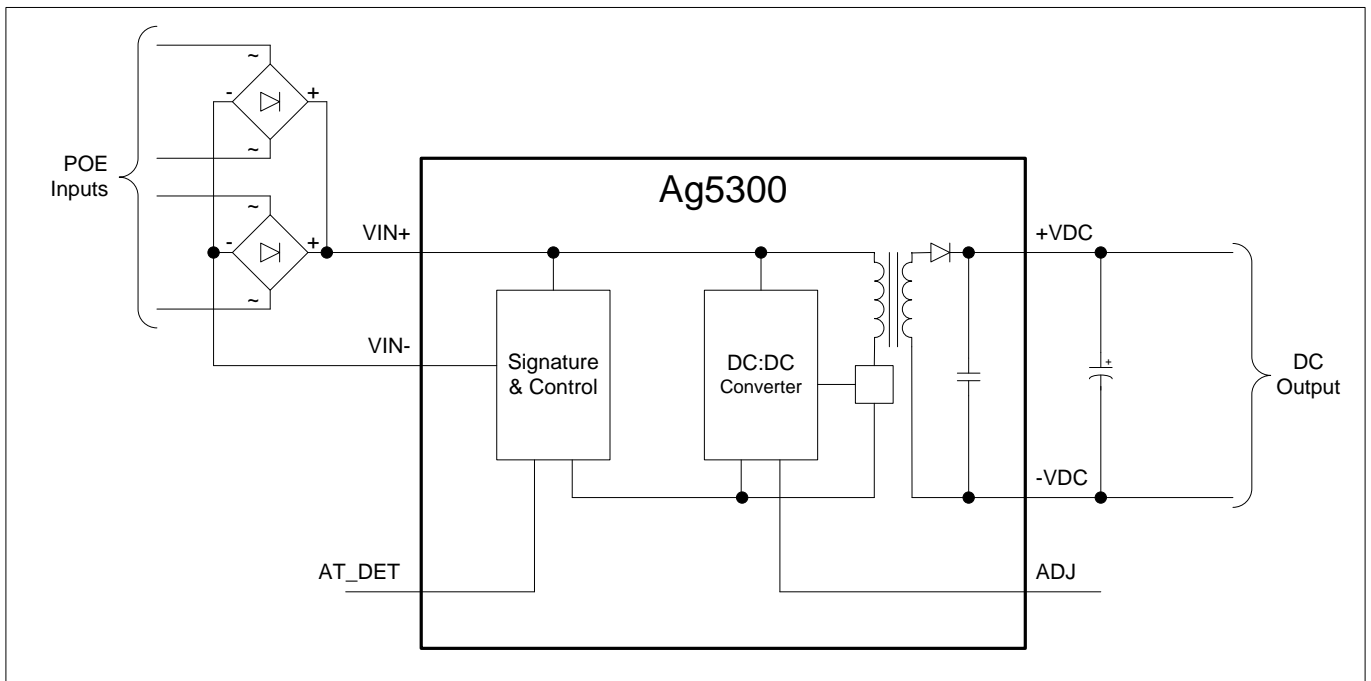

Figure 1: Block Diagram

4 Pin Description

Pin #	Name	Description
1	VIN+	POE Direct Input +. This pin connects to the positive (+) output of the POE input bridge rectifiers.
2	VIN-	POE Direct Input -. This pin connects to the negative (-) output of the POE input bridge rectifiers.
3	AT-DET	AT Detect Output. This pin indicates if an IEEE802.3at PSE is supplying power to the Ag5300; see Section 5.5 for more details.
4	IC	Internal Connection. Do not connect to this pin.
5	IC	Internal Connection. Do not connect to this pin.
6	IC	Internal Connection. Do not connect to this pin.
7	-VDC	Negative DC Output. This pin provides the negative regulated output from the Ag5300 and is internally connected to pin 10.
8	+VDC	Positive DC Output. This pin provides the positive regulated output from the Ag5300.
9	ADJ	Output Adjust. The output voltage can be adjusted from its nominal value, by connecting an external resistor from this pin to either the +VDC pin or the -VDC pin.
10	-VDC	Negative DC Output. This pin provides the negative regulated output from the Ag5300 and is internally connected to pin 7.

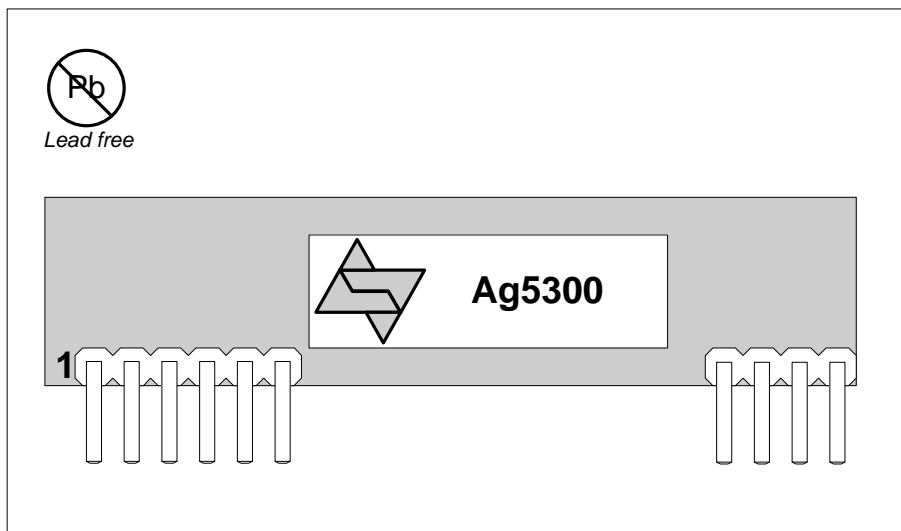

Figure 2: Ag5300 SIL Package Format

5 Functional Description

5.1 Inputs

The Ag5300 has two input pins VIN+ and VIN-, these pins must be connected to outputs of two external bridge rectifiers*, to ensure that the inputs are polarity protected. This allows the Ag5300 to be compatible with power sourcing equipment that uses the different power options (power on the Data Pair or power on the Spare Pair); see Figure 3.

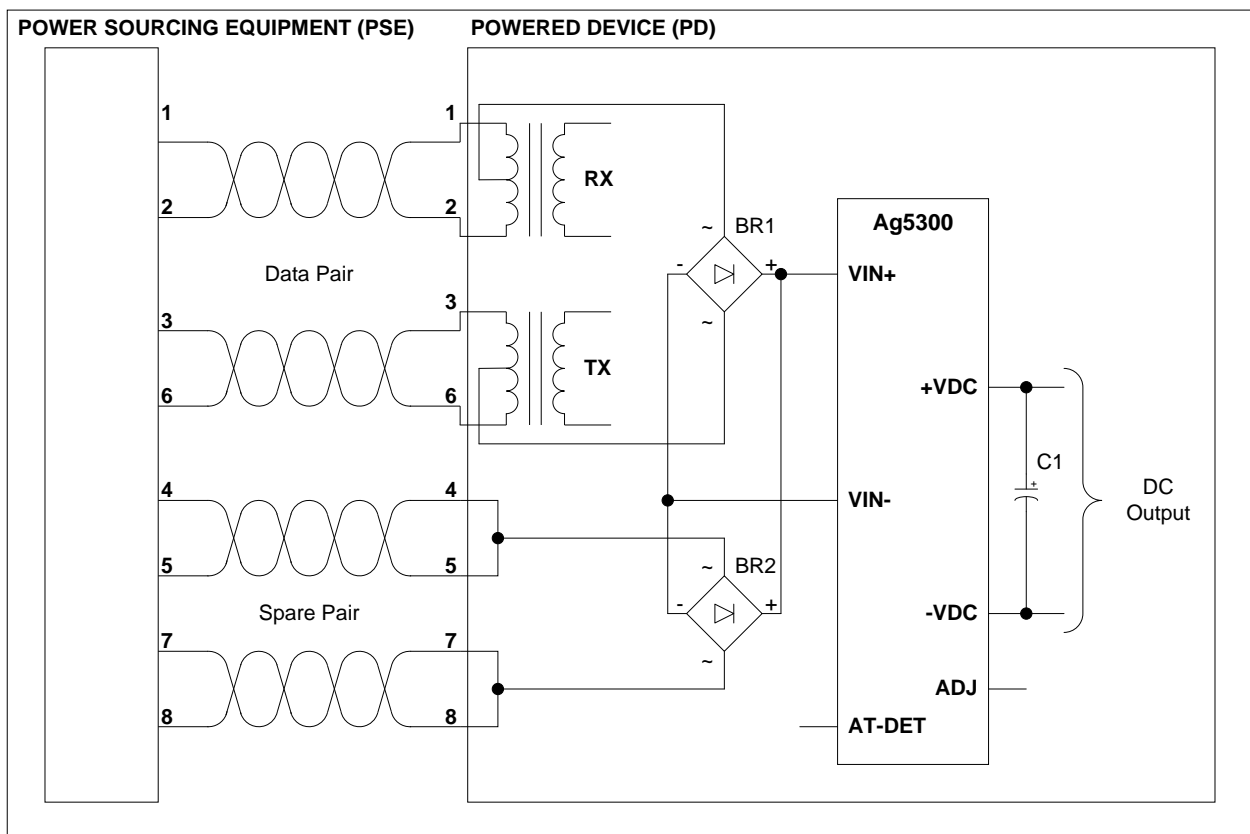

Figure 3: Typical System Diagram

*Note: Suitable bridge rectifier for BR1 & BR2 would be a “DF01S” or equivalent.

5.2 PD Signature

When the Ag5300 is connected to the Cat 5e cable, it will automatically present a Powered Device (PD) signature to the PSE, when requested. The PSE will recognise that a PD is connected to that line and supply power.

5.3 Isolation

To meet the safety isolation requirements of IEEE802.3at section 33.4.1. A PD must pass the electrical strength test of IEC 60950-1:2001 sub clause 6.2.1. This calls for either a) 1500Vac test or b) 2250Vdc test or c) 1500Vdc impulse test. The Ag5300 has been designed to meet c) 1500Vdc impulse test.

5.4 Power Classification

The Ag5300 classification is fixed at Class 4, this means that an IEEE802.3at Type 1 or an IEEE802.3af PSE will default to Class 0. However an IEEE802.3at or IEEE802.3bt PSE will recognise the Class 4 as a Type 2 PD.

5.5 AT Detection

The Ag5300 has an AT-DET output pin which is used to detect a Two Event Physical Layer classification as described in IEEE802.3at. If required the AT-DET pin can be connected directly to an opto-coupler as shown in Figure 4.

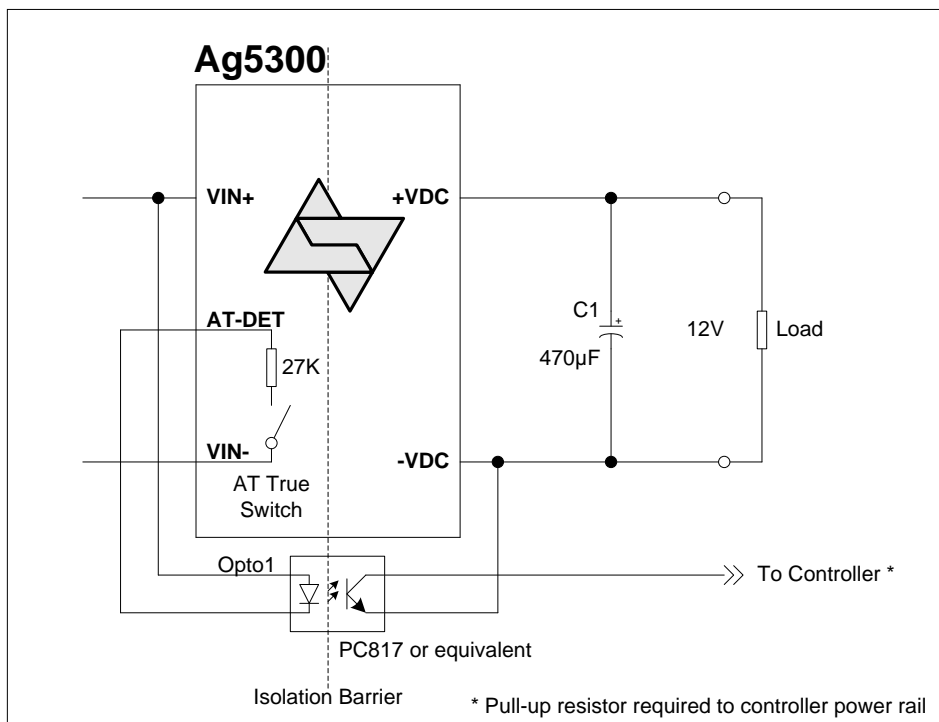

Figure 4: Two Event Physical Layer Detect Configuration

If the Ag5300 detects a Two Event Physical Layer classification, the (AT True) switch will close and Opto1 will turn ON. Opto1 will pass this signal across the isolation barrier and the output collector can be connected to a controller (with a pull-up resistor connected to the controller's power rail). When Opto1 is ON the collector (output) will be Logic 0, the controller will then know that the PSE is capable of delivering over 15.4W. To complete the

protocol (and conform to the IEEE802.3at specification) the controller should then confirm that it is a Type 2 PD over the Data Link Layer*.

If the Ag5300 detects a Single Event Physical Layer classification, Opto1 will be OFF and the output collector will be Logic 1 (via pull-up resistor). The controller should then assume that the PSE is limited to only delivering up to 15.4W.

If the PSE does not support the Physical Layer classification, Opto1 will be OFF.

The Ag5300 will operate with non IEEE802.3at compliant POE+ PSE's.

**Note: There are several PSEs (including Cisco) that will only delivery $\leq 15.4W$ until they receive Type 2 PD confirmation, over the Data Link Layer.*

5.6 DC/DC Converter

The Ag5300's DC/DC converter provides a regulated 5V, 12V or 24V (nominal) output with low ripple and low noise.

The DC/DC converter circuit also has built-in output overload and short-circuit protection.

In addition to the overload and short-circuit protection; the Ag5300 has built-in thermal protection circuit. This circuit will shutdown the DC/DC converter if the maximum operating temperature is exceeded.

5.7 Output Adjustment

The Ag5300 has an ADJ pin, which allows the output voltage to be increased or decreased from its nominal value.

Figure 5 shows how the ADJ pin is connected: -

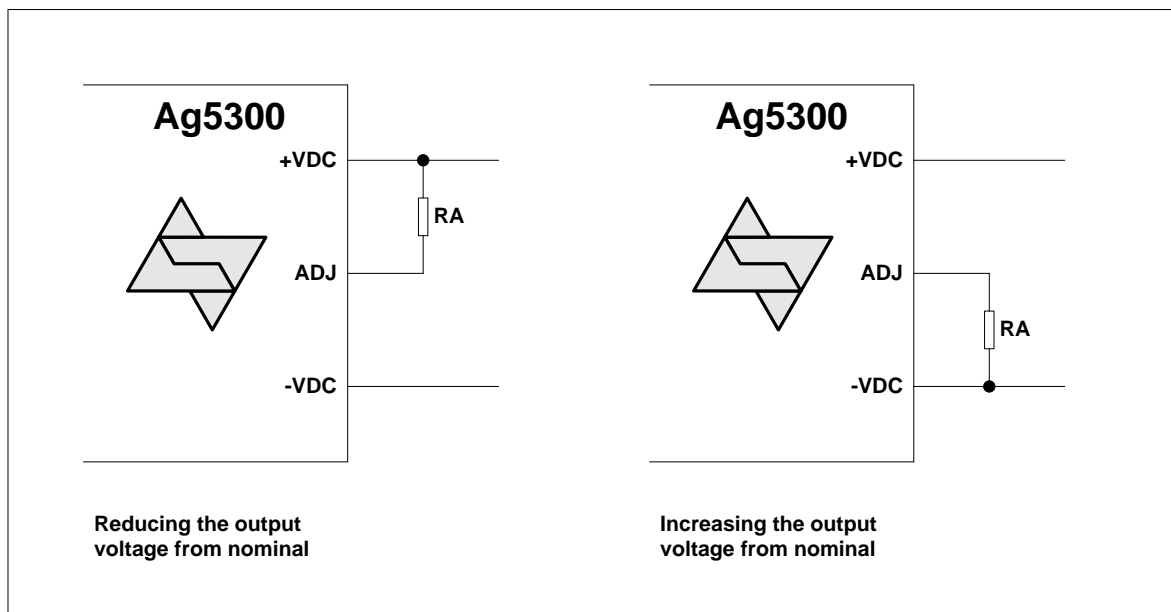

Figure 5: Output Adjustment

Reducing the output voltage, connect RA between ADJ and +VDC			
Value of RA	Ag5300 output	Ag5305 output	Ag5324 output
Open Circuit	12.0V	5.0V	24.0V
68K Ohms	10.8V*	4.7V	21.6V*
0 Ohms**	-	4.4V	-

Increasing the output voltage, connect RA between ADJ and -VDC			
Value of RA	Ag5300 output	Ag5305 output	Ag5324 output
Open Circuit	12.0V	5.0V	24.0V
0 Ohms	12.8V	5.8V	24.8V

Table 2: Output Adjustment Resistor (R) Value

*Note: It is important that the minimum output adjust is not taken below 10.8V (12V Nominal) and 21.6V (24V Nominal). Setting the output voltage below this level may result in the module being permanently damaged.

**Note: Only to be used on the Ag5305.

5.8 Typical Connections

The Ag5300 only requires a few external components - the bridge rectifiers on the VIN input are to conform to the IEEE802.3at input polarity protection requirement. The 470 μ F capacitor (C1) connected across the output is needed for stability and to cope with load step changes. This capacitor must be positioned as close to the output pins as possible. It can be a low cost electrolytic capacitor (a minimum of 470 μ F 16V is recommended for 5V and 12V and 220 μ F 25V for 24V) as shown in Figure 6; it does not need to be a low ESR type for operation in temperatures down to 0°C. But if ambient temperature is likely to go below 0°C then we would recommend a low ESR electrolytic capacitor.

The output voltage can be adjusted by simply connecting a resistor between the ADJ pin and either the +VDC Pin or the -VDC pin, see section 5.7 Output Adjustment.

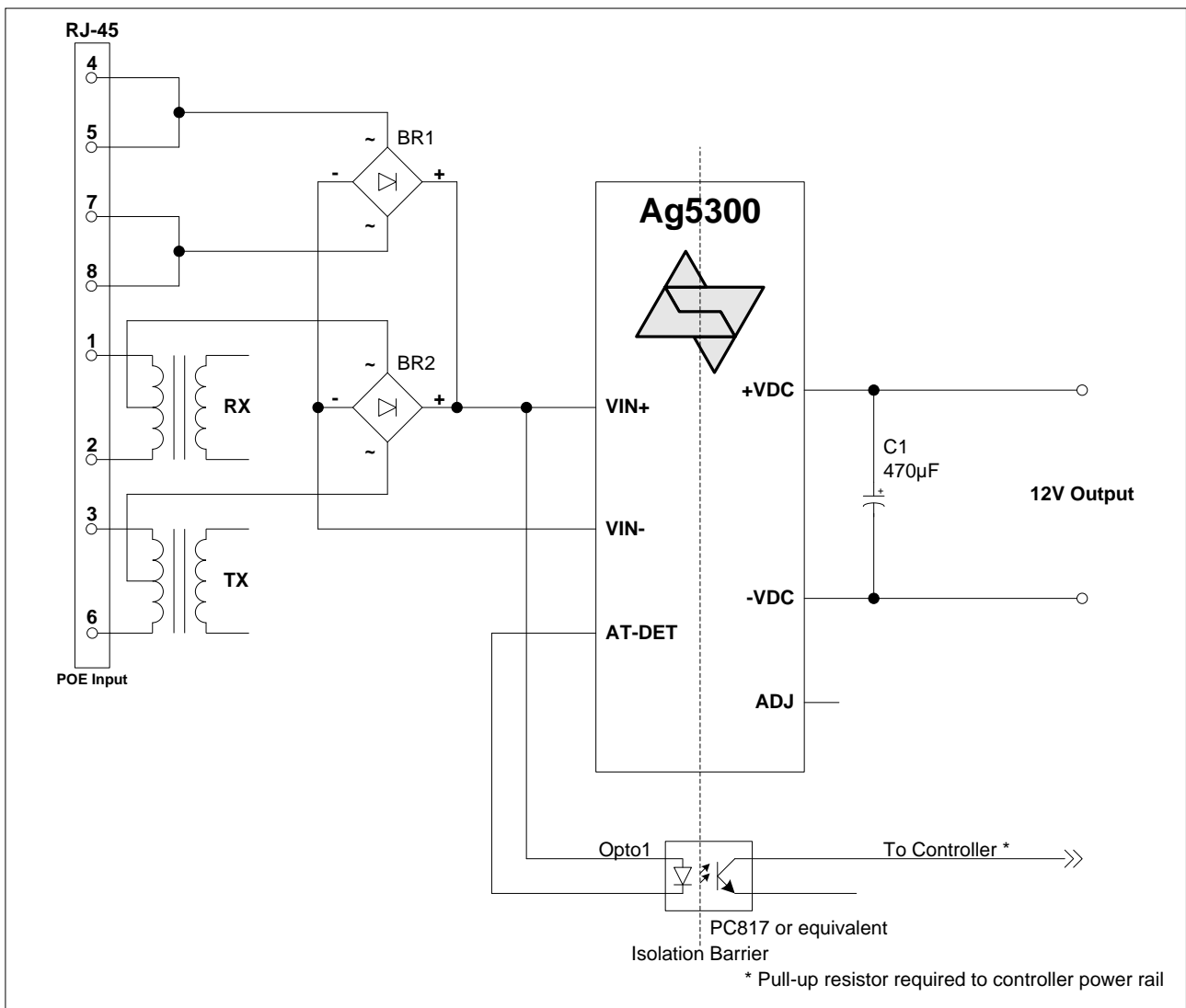

Figure 6: Typical PoE Only Connection Diagram

5.9 Minimum Load

The Ag5300 must always supply the minimum load current, see Table 11.3.

When operated below this current, the Ag5300 can emit a low level audible noise and may cause some PSEs to fail the Maintain Power Signature (MPS) and switch its output off.

The reason that the module emits this noise is due to the dc/dc converter running in discontinuous mode.

If this audible noise is not an issue, then the Ag5300 can work safely with a much smaller load. But to ensure that the PSE has a sufficient load to meet the PSEs MPS, it would be advisable not to operate the Ag5300 below the specified minimum load.

5.10 Output Power

The Ag5300 and Ag5324 are capable of delivering a maximum output power of 24W continuous, with short peak transients of up to 30W. The Ag5305 is capable of delivering a maximum output power of 20W continuous, with short peak transients of up to 22.5W. However this is limited by the available input power and operating temperature.

When calculating the output power, the following factors must be taken into account: -

1. Ag5300 efficiency
2. PSE output power (which could be limited by the IEEE802.3at specification)
3. Cable and connector losses
4. Input bridge rectifier losses
5. Operating temperature

6 Typical Application

The Ag5300 can be used in numerous applications. In the example shown in Figure 7, the data outputs from the switch are connected to the inputs of a midspan. The midspan will then add power (to the data) on each output that supports POE.

In this example port 1 is connected to an ethernet camera and port 2 is connected to a door entry access unit, both of these devices have a built-in Ag5300. When the midspan is switched on (or when the device is connected), the midspan will check each output for a POE signature. On ports 1 and 2 the Ag5300 will identify themselves as POE enabled devices and the midspan will supply both data and power to these peripherals.

The other ports (shown in this example) will not have a PoE signature and the midspan will only pass the data through to these peripherals. The midspan will continuously monitor each output to see if a POE enabled device has been added or removed.

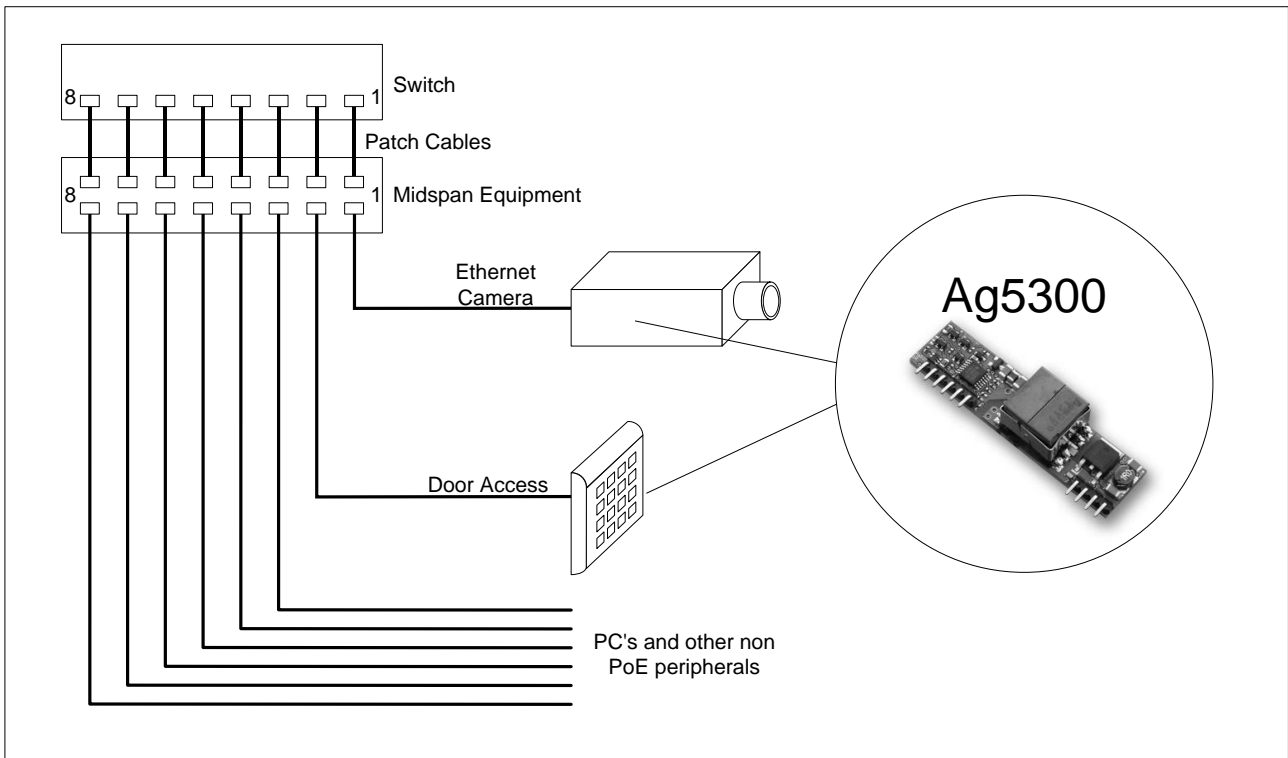

Figure 7: Typical Application

7 Layout Consideration

Figure 8 shows an example board layout for the Ag5300.

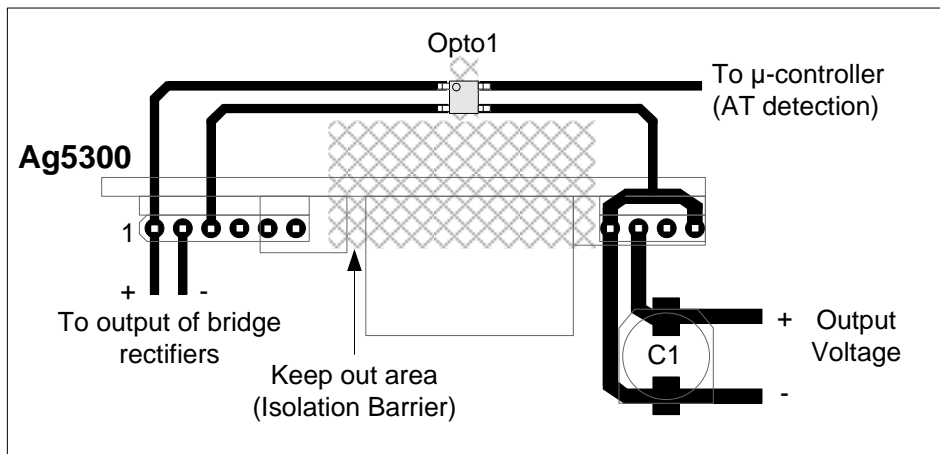

Figure 8: Layout Consideration

8 Operating Temperature Range

Because the Ag5300 is a power component, it will generate heat; so it is important that this be taken into consideration at the design stage.

The heart of the Ag5300 is a DC/DC converter, which like any other power supply will generate heat. The amount of heat generated by the module will depend on the load it is required to drive and the input voltage supplied by the PSE. The information shown within this section of datasheet is referenced to a nominal 52Vdc input voltage supplied by the PSE.

Because each application is different it is impossible to give fixed and absolute thermal recommendations. However to obtain maximum power it is important that any enclosure used has sufficient ventilation and forced airflow over the Ag5300.

When intended for used in ambient temperatures below 0°C we would recommend a low ESR electrolytic capacitor be used on the DC output. Capacitors rated for -55°C operation should be used below 0°C.

The Ag5300 and Ag5324 is capable of handling 30W peak power for short durations, but this will de-rate the operating temperature profile of Figures 10&11. The graphs shown are at the maximum ambient temperature under continuous load conditions which has been recorded in an Associated Environment System SD-302 chamber (with circulating air). Operation in a sealed enclosure with limited airflow will also result in de-rating of the operating temperature profile.

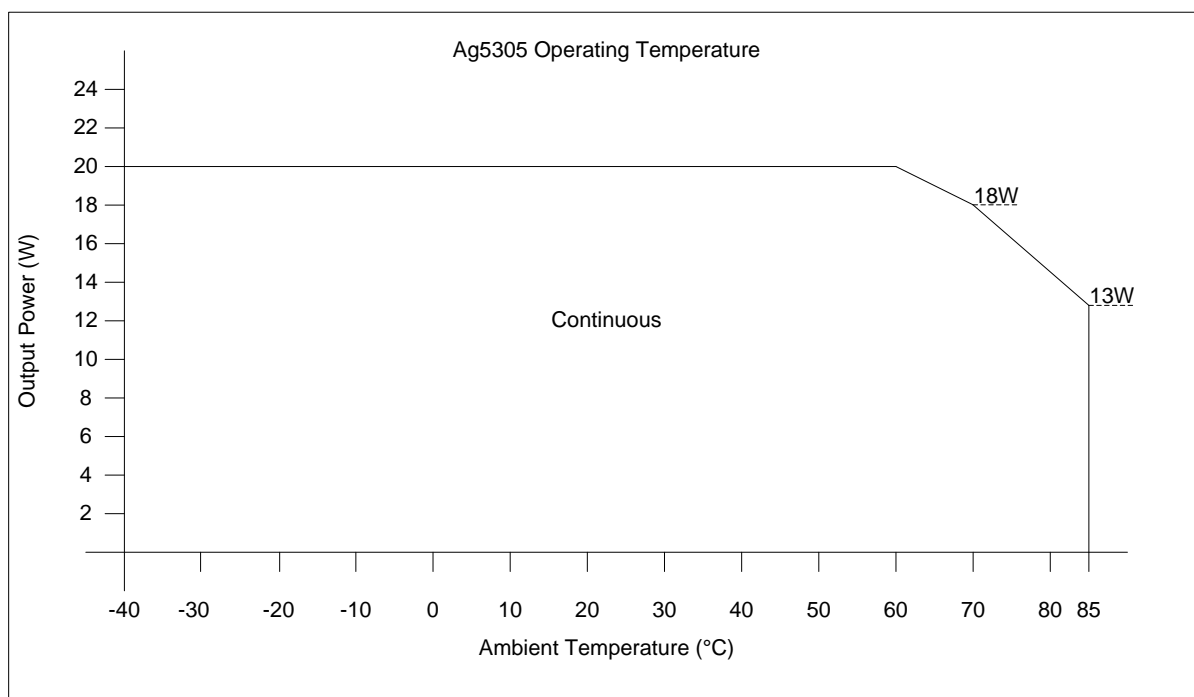

Figure 9: Ag5305 Operating Profile

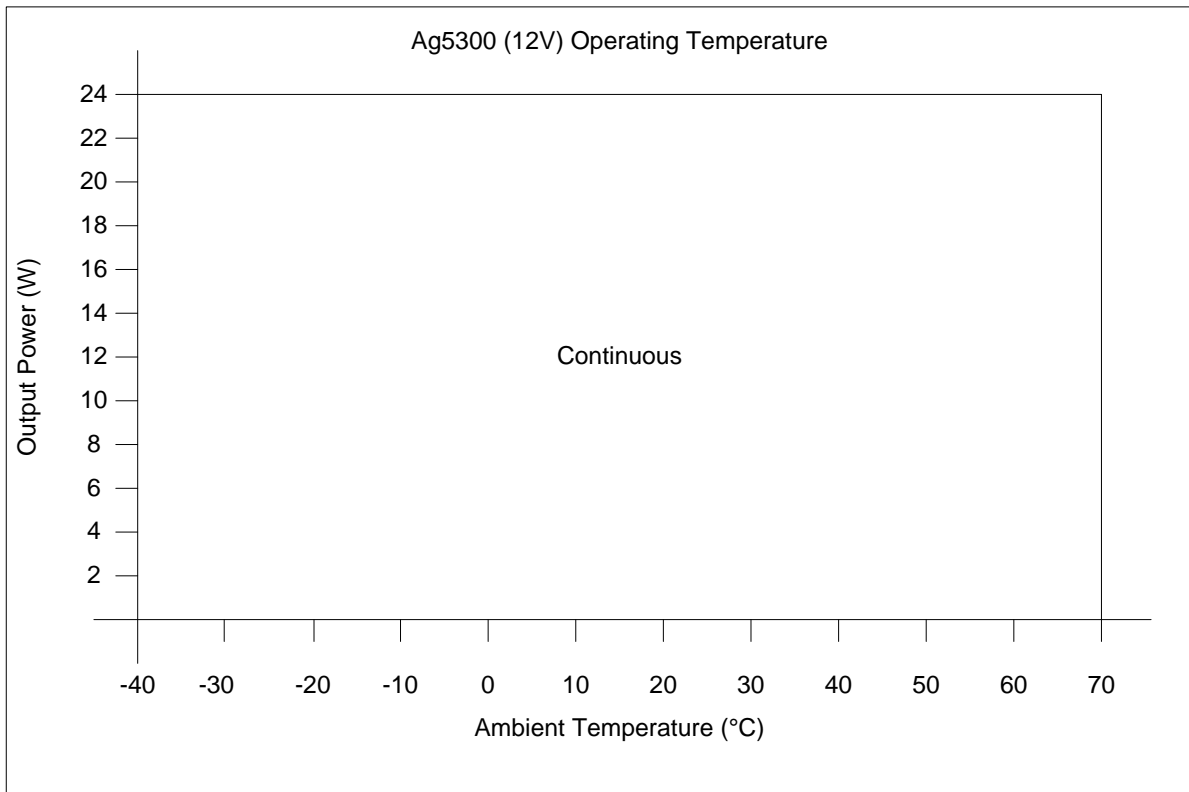

Figure 10: Ag5300 Operating Profile

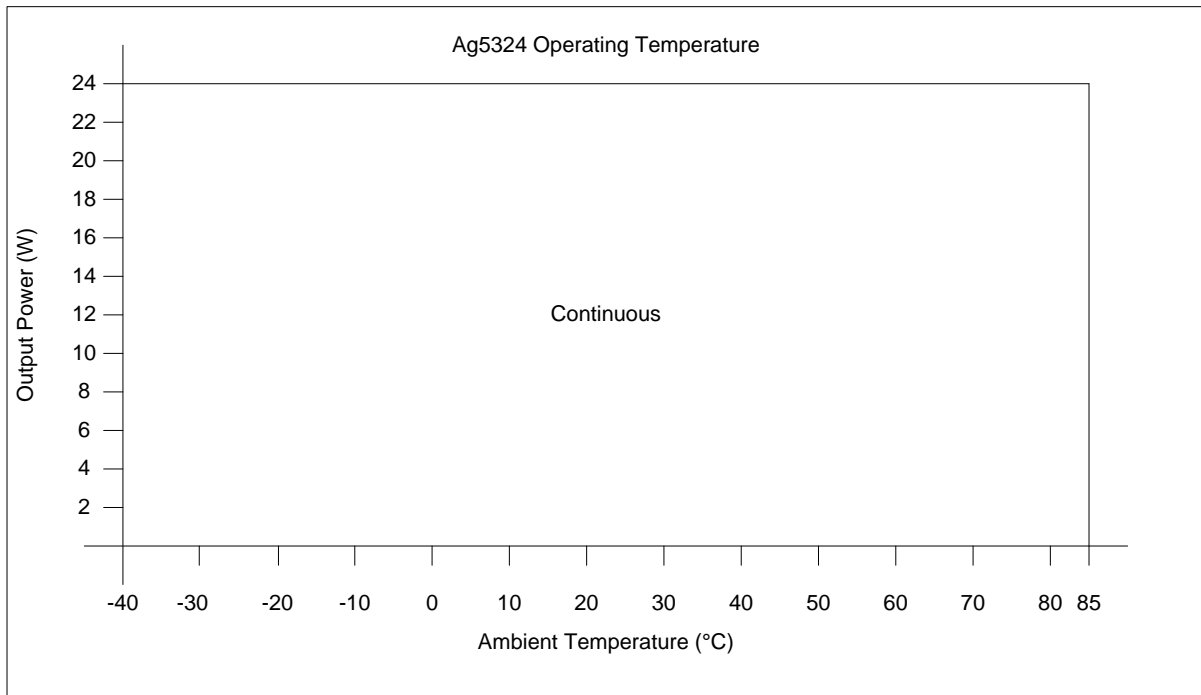

Figure 11: Ag5324 Operating Profile

Note: See Apps Note "ANX-POE-Thermal Considerations" for suggestions on thermal management.

One simple method to draw some of the heat away from the Ag5300 is shown in Figure 12.

Power planes will help draw heat away from the Ag5300. But it is important that these are on the outer layers of the PCB and the Ag5300 must not be fitted into a socket.

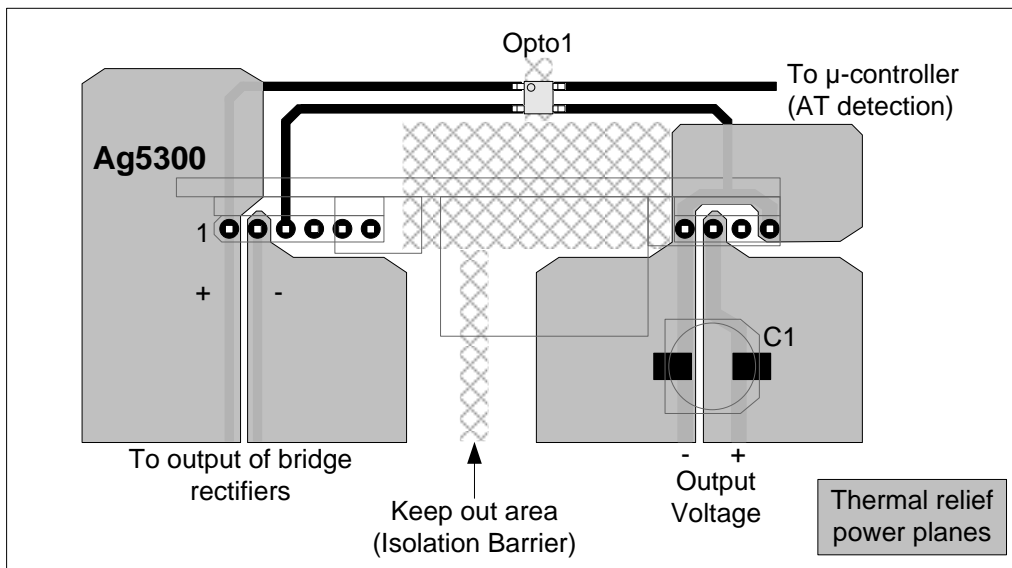

Figure 12: Thermal Relief Power Planes

9 Protection

The Ag5300 has built-in over-current and thermal protection to prevent the module from being damaged if operated beyond its power / temperature specification. If a short circuit is applied to the output, the DC/DC converter will limit the current until the short circuit is removed. If the maximum operating temperature is exceeded; the thermal protection circuit will disable the DC/DC converter until the Ag5300 temperature has cooled sufficiently.

The Ag5300 may be damaged by input voltage transients greater than 80V. If protection from electrostatic discharge (ESD) or other high voltage transients is required, it is recommended that an over-voltage clamping device is fitted across the VIN+ and VIN- input pins. Typically an SMAJ58A will be sufficient; see Figure 13.

Note: For more information refer to Apps Note “ANX-POE-Protection”.

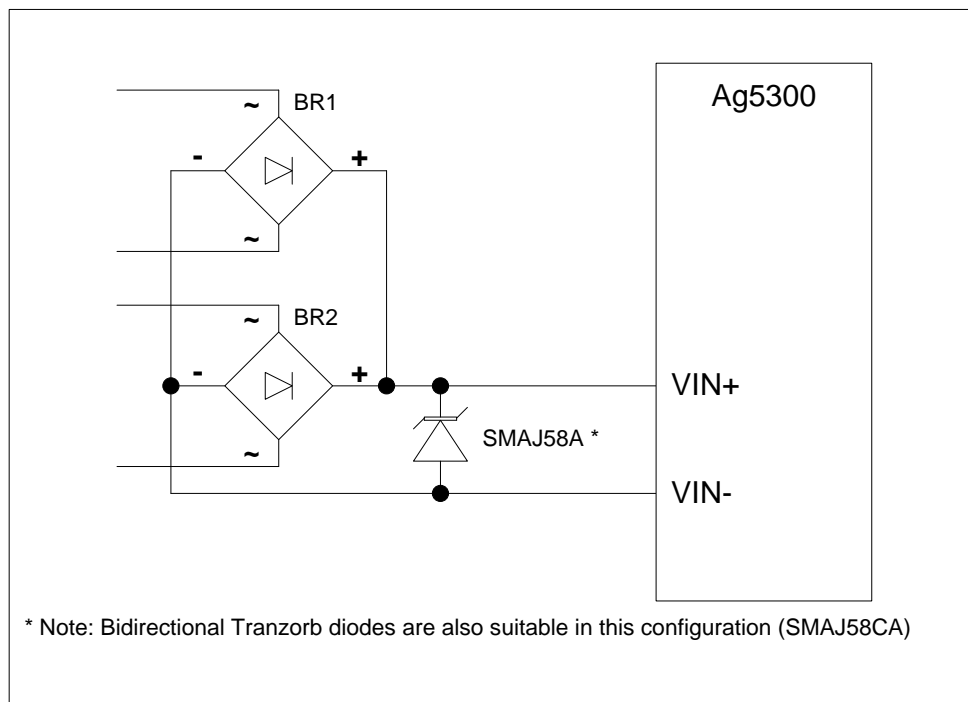

Figure 13: Input Protection

9.1 ESD

During an ESD event the Ag5300 internal protection shuts down its DC-DC converter to prevent any damage to the module. However if the customer requires the Ag5300 output to remain on during an ESD event we would advise connecting a 10nF capacitor between pin 5 and pin 2 of the Ag5300.

10 EMC

The Ag5300 has been designed to pass EN55022 Class b; however the Ag5300 will only be one component within a system. So it is impossible to say whether the final product will pass EMC testing without the need for additional filtering. Figure 14 shows an inexpensive but effective solution of reducing emissions.

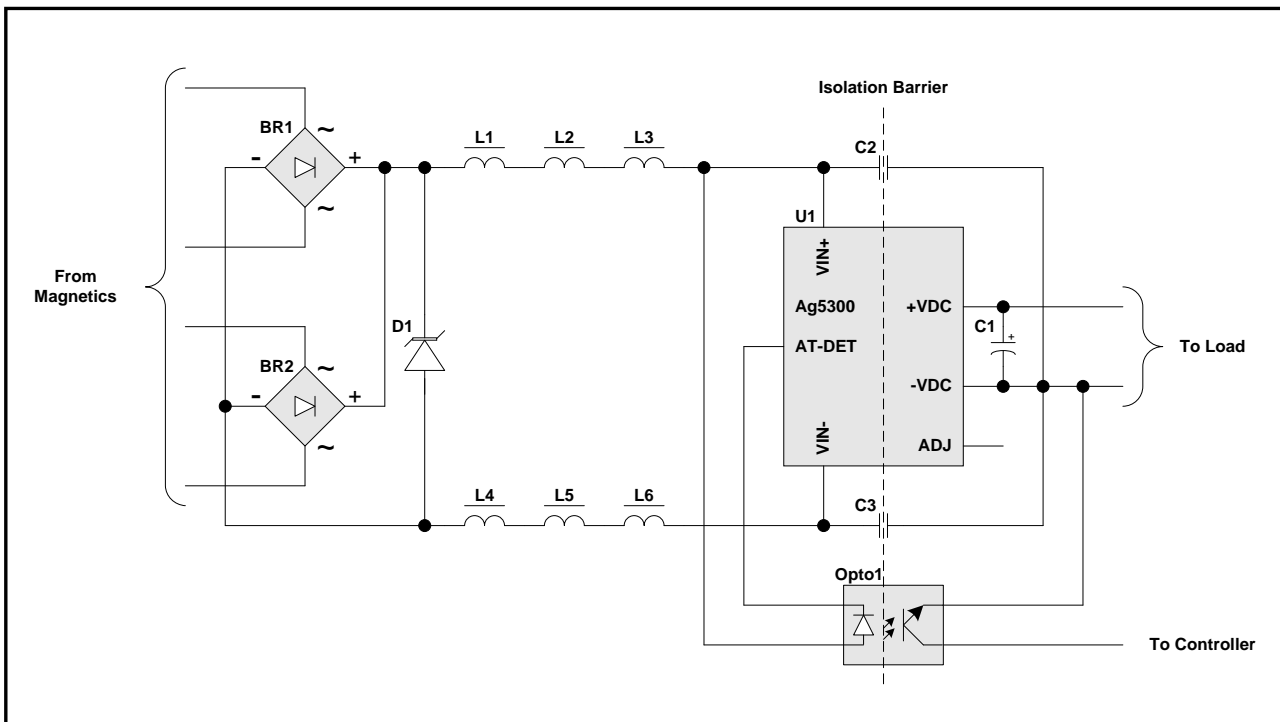

Figure 14:EMC Filtering

Components: -

BR1 & BR2 = DF01S, D1 = SMAJ58A, L1 – L6 = MPZ2012S102A, C1 = 470 μ F 16V (12V output or 220 μ F 25V for 24V output), Opto1 = KCP357NT, C2 & C3 = 4.7nF 2000V.

11 Electrical Characteristics

11.1 Absolute Maximum Ratings*

	Parameter	Symbol	Min	Max	Units
1	DC Supply Voltage	V_{CC}	-0.3	60	V
2	DC Supply Voltage Surge for 1ms	V_{SURGE}	-0.6	80	V
3	Storage Temperature	T_S	-40	+100	°C

*Exceeding the above ratings may cause permanent damage to the product. Functional operation under these conditions is not implied. Maximum ratings assume free airflow.

11.2 Recommended Operating Conditions

	Parameter		Symbol	Min	Typ	Max	Units
1	POE Input Supply Voltage		V_{IN}	36	48	57	V
2	POE Input Under Voltage Lockout		V_{LOCK}	30		36	V
3	Operating Temperature †	Ag5305 Ag5300 Ag5324	T_{OP}	-40	25	85 70 85	$T_a / ^\circ C$

†See Section 8 for continuous operation.

11.3 DC Electrical Characteristics*

	DC Characteristic	Device	Sym	Min	Typ ¹	Max	Units	Test Comments
1	Input Voltage v Output Power	Output Power ≤ 12W	V_{IN}	36		57	V	
		Output Power >12W to 24W		50		57	V	
2	Nominal Output Voltage	Ag5305	V_{OUT}	4.75	5	5.25	V	
		Ag5300		11.5	12	12.5	V	
		Ag5324		23.25	24	24.8	V	
3	Line Regulation $V_{IN} = 36V$ to $57V$ @ 50% load	Ag5305	V_{LINE}		0.1		%	
		Ag5300			0.1		%	
		Ag5324			0.03		%	
4	Load Regulation min to max load ($V_{IN} = 50V$)	Ag5305	V_{LOAD}		0.2		%	
		Ag5300			0.2		%	
		Ag5324			0.05		%	

5	Output Ripple and Noise Max load ²	Ag5305	V_{RN}		76.5		mVp-p	
		Ag5300			56		mVp-p	
		Ag5324			27		mVp-p	
6	Minimum Load ³	Ag5305	I_{LOAD}	400			mA	
		Ag5300		200			mA	
		Ag5324		100			mA	
7	Short-Circuit Duration		T_{SC}			∞	sec	Continuous @ 25 °C
8	Peak Efficiency	Ag5305	EFF		83.5		%	
		Ag5300			87		%	
		Ag5324			88		%	
9	Isolation Voltage (I/O)		V_{ISO}			1500	V_{PK}	Impulse Test

1: Typical figures are at 25°C with a nominal 52V supply and are for design aid only. Not Guaranteed

2: The output ripple and noise can be reduced with an external filter, see application note.

3: The module can emit an audible noise if operated at less than the specified minimum load and may cause the PSE to fail its MPS.

12 Package

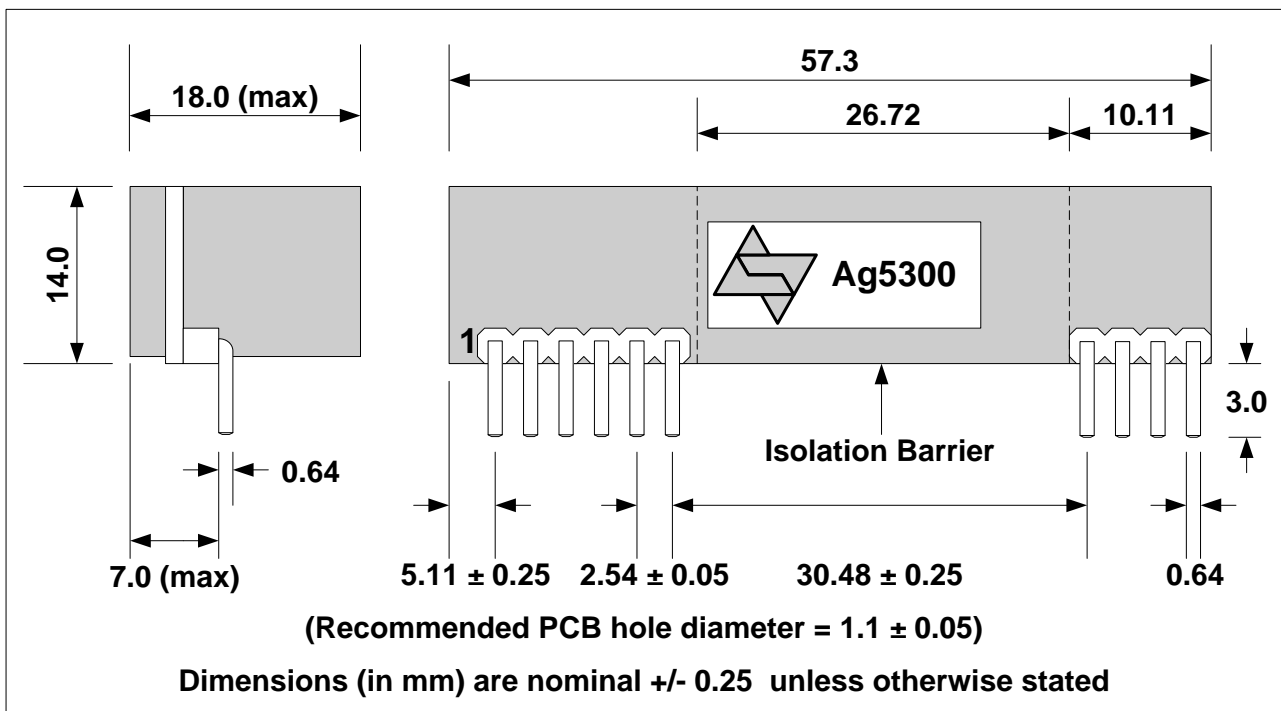

12.1 Plan View

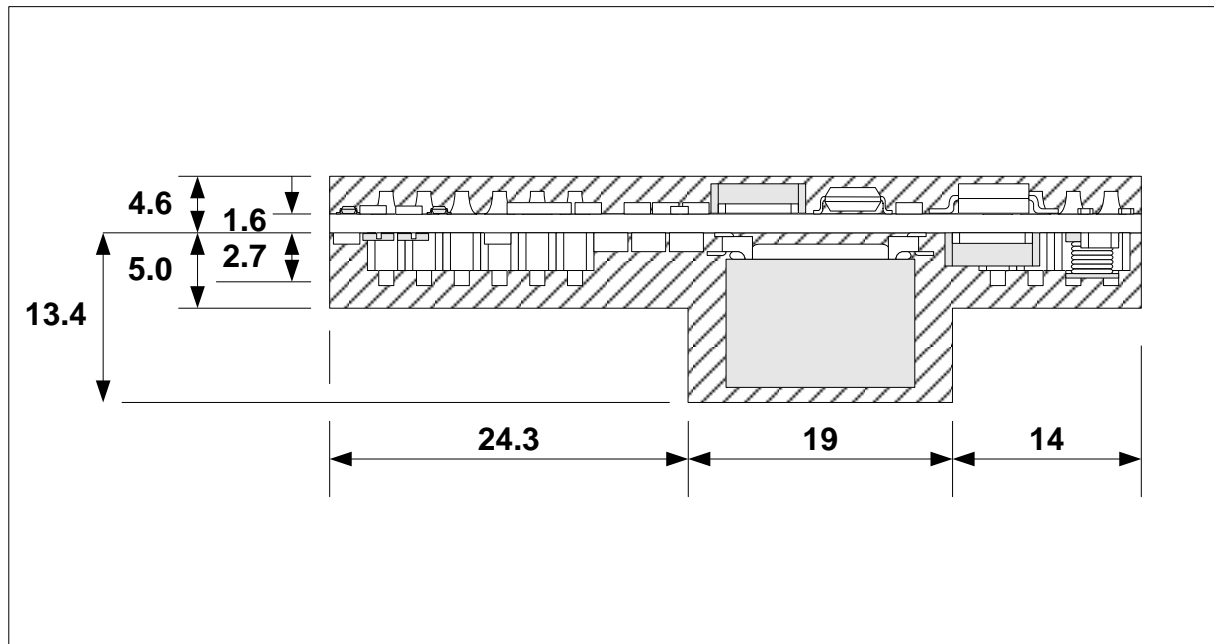

The latest revision of all application notes referenced in this document can be found on the Silver Telecom website "www.silvertel.com".

Information published in this datasheet is believed to be correct and accurate. Silver Telecom assumes no liability for errors which may occur or for liability otherwise arising out of use of this information or infringement of patents which may occur as a result of such use. No license is granted by this document under patents owned by Silver Telecom or licensed from third parties by Silver Telecom. The products, their specification and information appearing in this document are subject to change by Silver Telecom without notice.