

PLEASE CHECK WWW.MOLEX.COM FOR LATEST PART INFORMATION

Part Number: [0008560115](#)
Status: **Active**
Overview: [kk](#)
Description: KK® Cat Ear Crimp Terminal 4809, 22-30 AWG, Bag Selective Gold (Au)

Documents:

[Drawing \(PDF\)](#) [Product Specification PS-99020-0088 \(PDF\)](#)
[Product Specification PS-10-07 \(PDF\)](#) [RoHS Certificate of Compliance \(PDF\)](#)

General

Product Family	Crimp Terminals
Series	4809
Crimp Quality Equipment	Yes
Overview	kk
Product Name	Cat Ear, KK®

Physical

Gender	Female
Material - Metal	Brass
Material - Plating Mating	Gold
Material - Plating Termination	Gold
Packaging Type	Bag
Plating min: Mating (µin)	15.2
Plating min: Mating (µm)	0.38
Plating min: Termination (µin)	4.8
Plating min: Termination (µm)	0.12
Termination Interface: Style	Crimp or Compression
Wire Insulation Diameter	1.57mm (.062") max.
Wire Size AWG	22, 24, 26, 28, 30
Wire Size mm²	N/A

Material Info

Old Part Number	4809550L
-----------------	----------

Reference - Drawing Numbers

Product Specification	PS-10-07, PS-99020-0088
Sales Drawing	SD-4809*

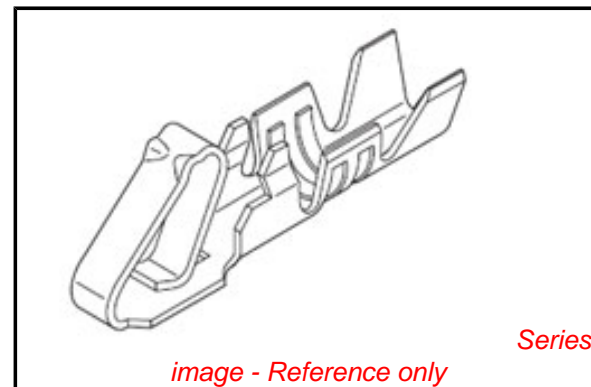

image - Reference only

EU RoHS

**ELV and RoHS
Compliant**
**REACH SVHC
Contains SVHC: No**
**Halogen-Free
Status**

China RoHS



**Need more information on product
environmental compliance?**

Email productcompliance@molex.com
 For a multiple part number RoHS Certificate of Compliance, [click here](#)

Please visit the [Contact Us](#) section for any non-product compliance questions.

Search Parts in this Series

[4809Series](#)

Application Tooling | [FAQ](#)

Tooling specifications and manuals are found by selecting the products below. Crimp Height Specifications are then contained in the Application Tooling Specification document.

Global

Description	Product #
Hand Crimp Tool	0638118200

NOTES*

1. MATERIAL: (0.2)/.008 THICK BRASS 70/30, FOR MATL. SPEC SEE SHEET 2.
2. SUITABLE FOR 22-30 GA WIRE, (1.57)/.062 MAX INSULATION.
3. CODE LETTER PRECEDING PART No DESIGNATES MANUFG. LOCATION, I=IRELAND.
4. TERMINAL MUST MEET BEND SPEC. SDES-219.
5. THIS PART CONFORMS TO PROD. SPEC. 99020-0088

SECTION D-D
(4809-1T ONLY)

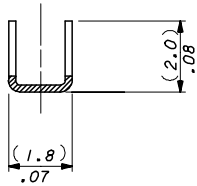

SECTION B-B

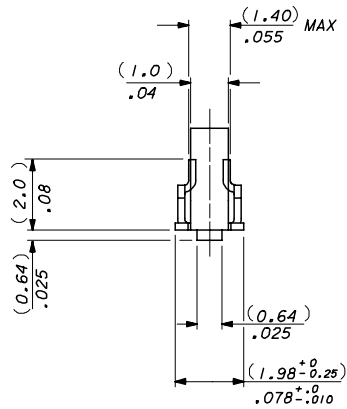

SECTION A-A

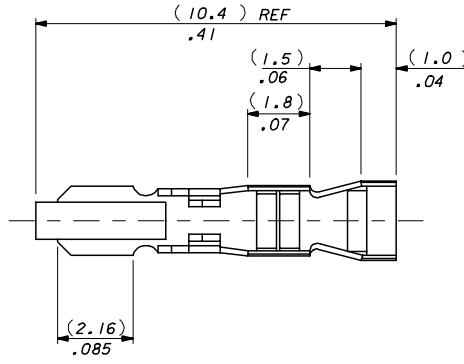
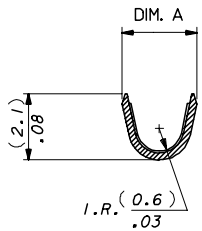

SELECTIVE PLATING AREA,
SEE CHART AND SDES-186

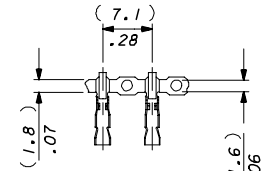
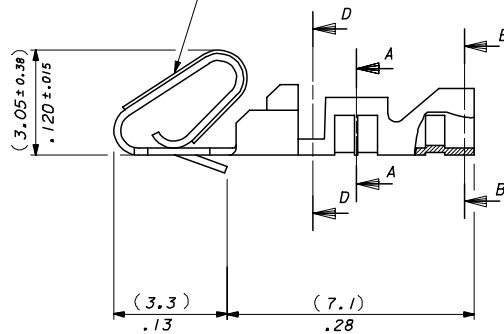

CARRIER STRIP DETAIL
SCALE 2:1

4809-(*)**

BLANK : DIM. A = (2.45-1.75) / .096-.069

M: DIM A = (2.35-2.05) / .093-.081

BLANK-CHAIN FORM TOP
FEEDING REEL
L-LOOSE FORM

BF-CHAIN FORM, BOTTOM
FEEDING REEL

PLATING CODE

DIM CORRECTION EC NO. E2007-0218 DRAWN: JDENNEHY 2006/09/15 CHKD: DMOR IARTY 2006/09/15 APPR: JDENNEHY 2006/10/11	DESCRIPTION	QUALITY SYMBOLS	GENERAL TOLERANCES (UNLESS SPECIFIED)	DIMENSION STYLE	SCALE	DESIGN UNITS	THIRD ANGLE PROJECTION																
		$\nabla=0$ $\nabla=0$	<table border="1"> <tr> <th></th> <th>mm</th> <th>INCH</th> </tr> <tr> <td>4 PLACES</td> <td>± .005</td> <td>± .0004</td> </tr> <tr> <td>3 PLACES</td> <td>± .0075</td> <td>± .0003</td> </tr> <tr> <td>2 PLACES</td> <td>± .010</td> <td>± .0002</td> </tr> <tr> <td>1 PLACE</td> <td>± .015</td> <td>± .0001</td> </tr> <tr> <td colspan="3">ANGULAR ± .005</td> </tr> </table>		mm	INCH	4 PLACES	± .005	± .0004	3 PLACES	± .0075	± .0003	2 PLACES	± .010	± .0002	1 PLACE	± .015	± .0001	ANGULAR ± .005			MM/IN	10:1
	mm	INCH																					
4 PLACES	± .005	± .0004																					
3 PLACES	± .0075	± .0003																					
2 PLACES	± .010	± .0002																					
1 PLACE	± .015	± .0001																					
ANGULAR ± .005																							
REV	AL	DRAFT WHERE APPLICABLE MUST REMAIN WITHIN DIMENSIONS	SEE CHART	MATERIAL NO.	DOCUMENT NO.	SHEET NO.																	
				SD-4809-*		1 OF 2																	

FINISH NOTES*

- (P902) HOT TIN DIP 1.0- 2.5µM/(.000040 - .000100)
- (999) UNPLATED
- (109) ELECTRO TIN PLATE (7.6-10µM)/.000300-.000400 OVER (1.25-2.0µM)/.000050-.000080 COPPER.
- (505) GOLD PLATE (1.25-1.5µM)/.000050-.000060 OVER (1.25-2.0µM)/.000050-.000080 NICKEL.
- (506) GOLD PLATE (1.25-1.5µM)/.000050-.000060 OVER (2.5-3.25µM)/.000100-.000130 NICKEL.
- (507) GOLD PLATE (2.5-2.75µM)/.000100-.000110 OVER (1.25-2.0µM)/.000050-.000080 NICKEL.
- (509) GOLD PLATE (1.25-1.5µM)/.000050-.000060 OVER (0.76-2.0µM)/.000030-.000080 NICKEL.
- (550) GOLD PLATE (0.38-0.63µM)/.000015-.000025 OVER (0.76-1.5µM)/.000030-.000060 NICKEL IN CONTACT AREA WITH (0.12µM)/.000005 MIN. GOLD FLASH OVERALL.
- (555) SELECTIVE GOLD (0.38µM)/.000015 OVER (0.76µM)/.000030 IN CONTACT AREA ONLY.
- (558) GOLD PLATE (0.76-1.5µM)/.000030-.000060 OVER (1.25-2.0µM)/.000050-.000080 NICKEL IN CONTACT AREA WITH (0.12µM)/.000005 MIN. GOLD FLASH OVERALL.

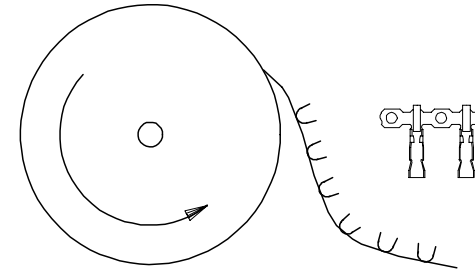

TERMINALS FEEDING FROM THE TOP OF THE REEL ARE STANDARD WOUND

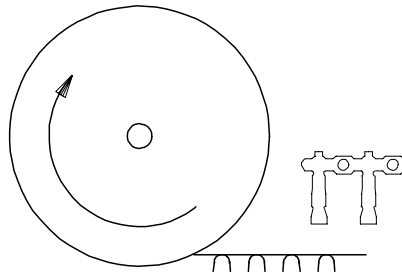

TERMINALS FEEDING FROM THE BOTTOM OF THE REEL ARE REVERSE WOUND SEE NOTE 5

I	08-50-0022	4809-(109)BF	CHAIN	(109)	(2.1)/.083 REF
I	40-01-0831	↑ -(999)BF	↑	(999)	(2.1)/.083 REF
	NT	-(505)BF		(505)	(2.1)/.083 REF
	NT	-(507)BF		(507)	(2.1)/.083 REF
I	08-55-0119	↓ -(555)BF	↓	(555)	(2.1)/.083 REF
I	08-56-0155	↓ -(550)BF	↓	(550)	(2.1)/.083 REF
I	08-50-0021	4809-(P902)BF	CHAIN	(P902)	(2.1)/.083 REF
	PART No	ENG No	FORM	FINISH	DIM . A

BOTTOM FEEDING REELS ONLY

	NT	4809-(506)	CHAIN	(506)	ES-99001-0014	(2.1)/.083 REF
	NT	↑ -(506)JL	LOOSE	(506)		(2.1)/.083 REF
I	08-56-0158	↓ -(558)JL	CHAIN	(558)		(2.1)/.083 REF
	NT	-(558)JL	LOOSE	(558)		(2.1)/.083 REF
	NT	-(509)JL	CHAIN	(509)		(2.1)/.083 REF
	NT	-(509)JL	LOOSE	(509)		(2.1)/.083 REF
	NT	-(109)JL	CHAIN	(109)		(2.1)/.083 REF
	NT	-(109)JL	LOOSE	(109)		(2.1)/.083 REF
I	40-01-0829	↓ -(999)JL	CHAIN	(999)		(2.1)/.083 REF
I	40-01-0830	↓ -(999)JL	LOOSE	(999)		(2.1)/.083 REF
	NT	-(505)JL	CHAIN	(505)		(2.1)/.083 REF
	NT	-(505)JL	LOOSE	(505)		(2.1)/.083 REF
	NT	-(507)JL	CHAIN	(507)		(2.1)/.083 REF
	NT	-(507)JL	LOOSE	(507)		(2.1)/.083 REF
I	08-55-0110	↓ -(555)JL	CHAIN	(555)		(2.1)/.083 REF
I	08-55-0111	↓ -(555)JL	LOOSE	(555)		(2.1)/.083 REF
	08-56-0120	↓ -(550)JL	CHAIN	(550)	ES-99001-0014	(2.1)/.083 REF
	08-56-0115	↓ -(550)JL	LOOSE	(550)		(2.1)/.083 REF
I	08-50-0135	↓ -(P902)JL	CHAIN	(P914)	ES-99001-0015	(2.1)/.083 REF
I	08-50-0136	4809-(P902)JL	LOOSE	(P914)	ES-99001-0015	(2.1)/.083 REF
	PART No	ENG No	FORM	FINISH	MATL. SPEC.	DIM . A

TOP FEEDING REELS ONLY

ADDED PART OPTION ECC NO: E2005-0286 DRWNG: MCKWEN 2004/11/03 CHKD: DMOR IART 2004/11/03 APPR: JDEWNEY 2004/11/04 REV	QUALITY SYMBOLS ▽=0 ▽=0	GENERAL TOLERANCES (UNLESS SPECIFIED) mm INCH 4 PLACES ± --- ± --- 3 PLACES ± --- ± .010 2 PLACES ± 0.25 ± .014 1 PLACE ± 0.35 ± --- ANGULAR ± --- °	DIMENSION STYLE MM/IN DRAWN BY DATE MCC 1986/07/30 CHECKED BY DATE DMOR IART 2004/10/18 APPROVED BY DATE JDEWNEY 2004/10/19	SCALE NTS DESIGN UNITS METRIC THIRD ANGLE PROJECTION	TITLE ANTI-FISH HOOKING TERMINAL KK,(2.50)/.100	
	DRAFT WHERE APPLICABLE MUST REMAIN WITHIN DIMENSIONS			MATERIAL NO. SEE CHART	DOCUMENT NO. SD-4809-*	SHEET NO. 2 OF 2
	MOLEX MOLEX INCORPORATED					
	THIS DRAWING CONTAINS INFORMATION THAT IS PROPRIETARY TO MOLEX INCORPORATED AND SHOULD NOT BE USED WITHOUT WRITTEN PERMISSION					