

General Features

- ◆ $V_{DS} = 60V, I_D = 0.3A$
 - $R_{DS(ON)} < 3.5\Omega @ V_{GS}=5V$
 - $R_{DS(ON)} < 3\Omega @ V_{GS}=10V$
 - ESD Rating : 1000V HBM
- ◆ High Power and current handling capability
- ◆ Lead free product is acquired
- ◆ Surface Mount Package

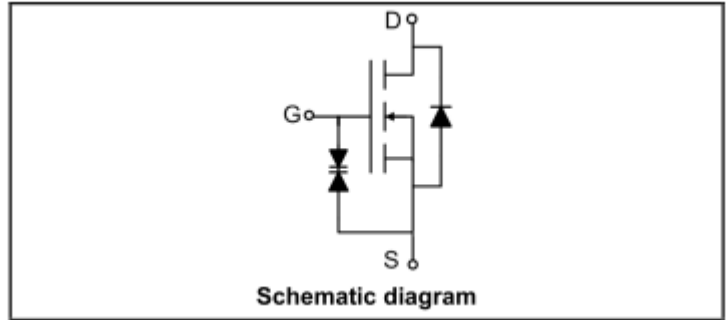

Application

- ◆ Direct Logic-Level Interface: TTL/CMOS
- ◆ Drivers: Relays, Solenoids, Lamps, Hammers, Display, Memories, Transistors, etc.
- ◆ Battery Operated Systems
- ◆ Solid-State Relays

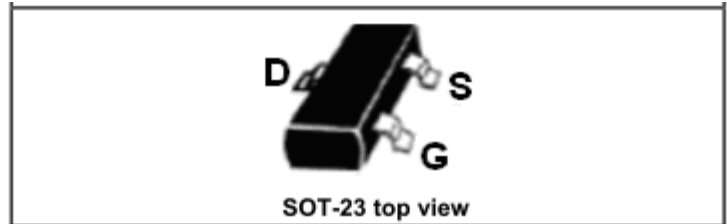

Absolute Maximum Ratings (TA=25°C unless otherwise noted)

Parameter	Symbol	Limit	Unit
Drain-Source Voltage	V_{DS}	60	V
Gate-Source Voltage	V_{GS}	± 20	V
Drain Current-Continuous@ Current-Pulsed (Note 1)	I_D	0.3	A
	$I_D(70^\circ C)$	0.26	A
	I_{DM}	0.8	A
Maximum Power Dissipation	P_D	0.43	W
Operating Junction and Storage Temperature Range	T_J, T_{STG}	-55 To 150	°C

Thermal Characteristics

Parameter	Symbol	Limit	Unit
Thermal Resistance, Junction-to-Ambient (Note 2)	$R_{\theta JA}$	350	°C/W

**Electrical Characteristics** ($T_A=25^{\circ}\text{C}$ unless otherwise noted)

Parameter	Symbol	Condition	Min	Typ	Max	Unit
OFF CHARACTERISTICS						
Drain-Source Breakdown Voltage	BVDSS	$V_{GS}=0V, I_D=-250\mu A$	60			V
Zero Gate Voltage Drain Current	IDSS	$V_{DS}=60V, V_{GS}=0V$			1	μA
Gate-Body Leakage Current	IGSS	$V_{GS}=\pm 5V, V_{DS}=0V$			100	nA
		$V_{GS}=\pm 10V, V_{DS}=0V$			150	nA
		$V_{GS}=\pm 20V, V_{DS}=0V$			10	μA
Gate-Source Breakdown Voltage	BVGSO	$V_{DS}=0V, I_G=\pm 250\mu A$	± 20			V
ON CHARACTERISTICS (Note 3)						
Gate Threshold Voltage	$V_{GS(th)}$	$V_{DS}=V_{GS}, I_D=-250\mu A$	1		2.5	V
Drain-Source On-State Resistance	RDS(ON)	$V_{GS}=10V, I_D=0.5A$			3	Ω
		$V_{GS}=5V, I_D=0.05A$			3.5	Ω
Forward Transconductance	gFS	$V_{DS}=10V, I_D=0.2A$	0.08			S
DYNAMIC CHARACTERISTICS (Note4)						
Input Capacitance	Ciss	$V_{DS}=25V, V_{GS}=0V,$ $F=1.0MHz$		30		PF
Output Capacitance	Coss			6		PF
Reverse Transfer Capacitance	Crss			3		PF
SWITCHING CHARACTERISTICS (Note 4)						
Turn-on Delay Time	td(on)	$V_{DD}=30V, V_{GS}=10V,$ $R_{GEN}=3\Omega, R_L=150\Omega$ $I_D=0.2A$			25	nS
Turn-Off Delay Time	td(off)				35	nS
Total Gate Charge	Qg	$V_{DS}=10V, I_D=0.25A, V_{GS}=4.5V$		0.4	0.6	nC
DRAIN-SOURCE DIODE CHARACTERISTICS						
Diode Forward Voltage (Note 3)	VSD	$V_{GS}=0V, I_S=0.2A$			1.3	V

NOTES:

1. Repetitive Rating: Pulse width limited by maximum junction temperature.
2. Surface Mounted on FR4 Board, $t \leq 10$ sec.
3. Pulse Test: Pulse Width $\leq 300\mu s$, Duty Cycle $\leq 2\%$.
4. Guaranteed by design, not subject to production testing.

Typical electrical and thermal characteristics

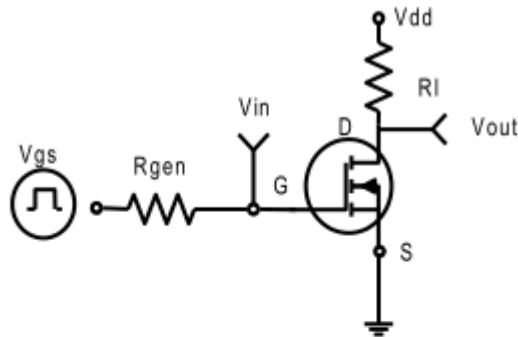

Figure 1: Switching Test Circuit

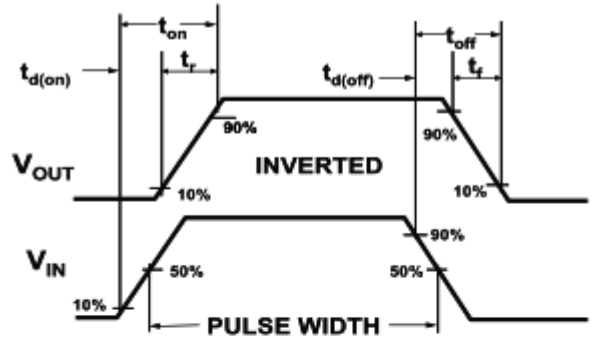

Figure 2: Switching Waveforms

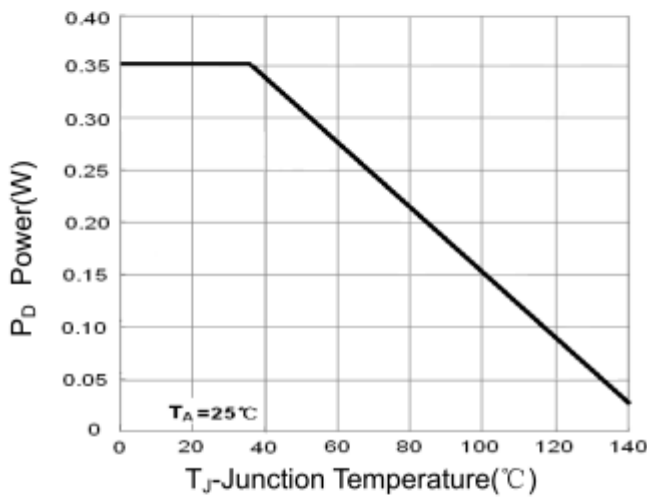

Figure 3 Power Dissipation

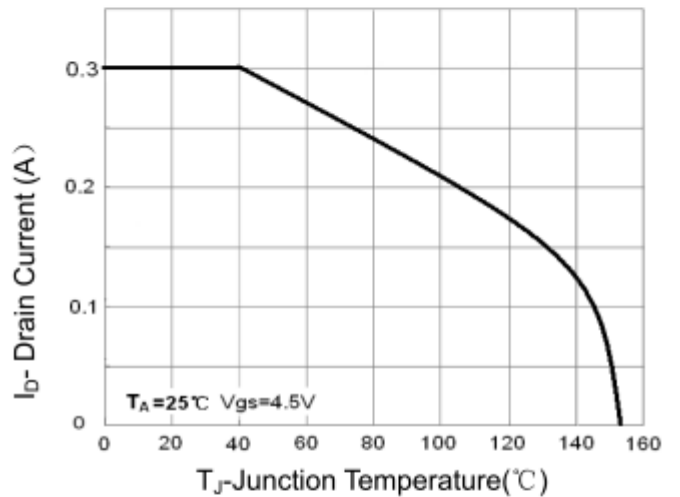

Figure 4 Drain Current

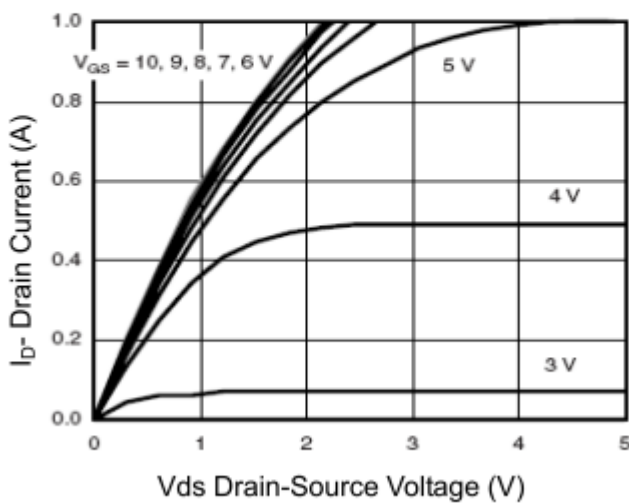

Figure 5 Output CHARACTERISTICS

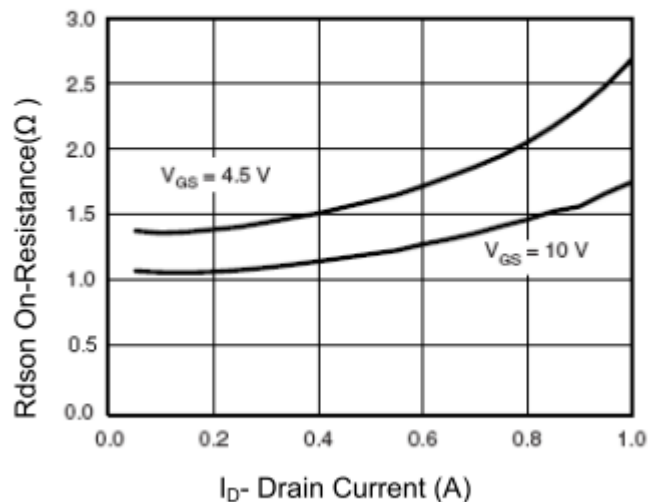

Figure 6 Drain-Source On-Resistance

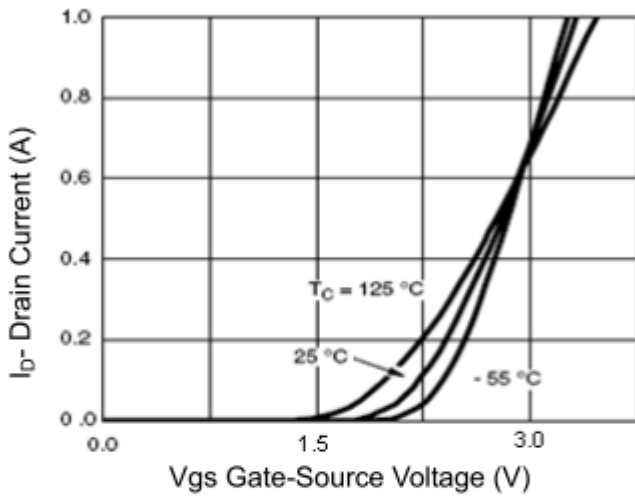

Figure 7 Transfer Characteristics

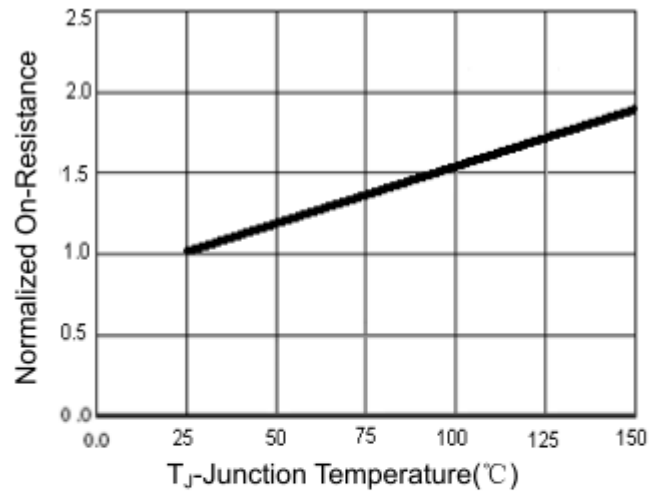

Figure 8 Drain-Source On-Resistance

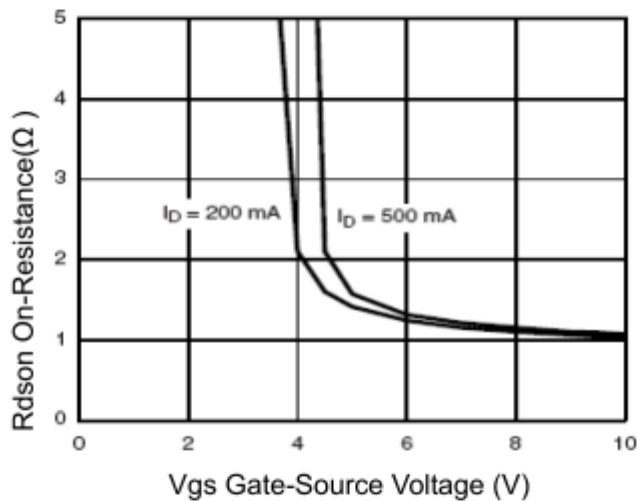

Figure 9 Rdson vs Vgs

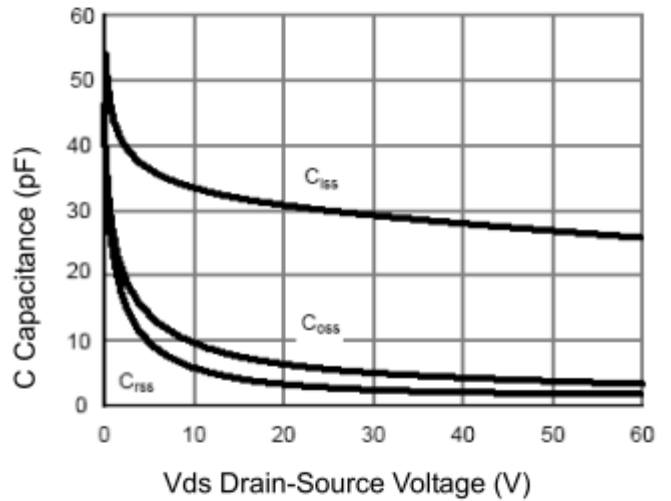

Figure 10 Capacitance vs Vds

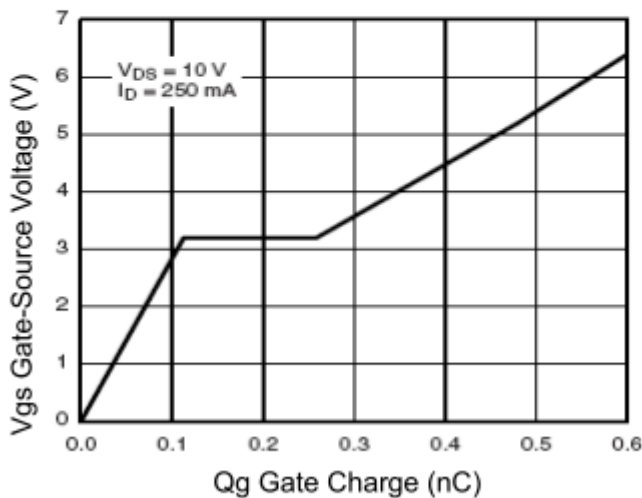

Figure 11 Gate Charge

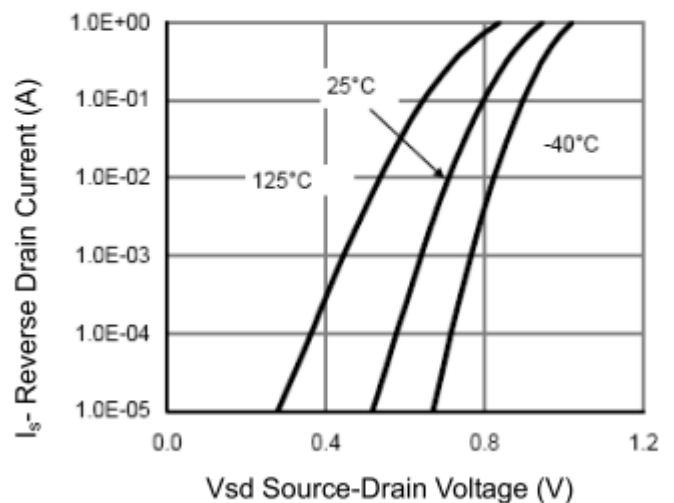

Figure 12 Source- Drain Diode Forward

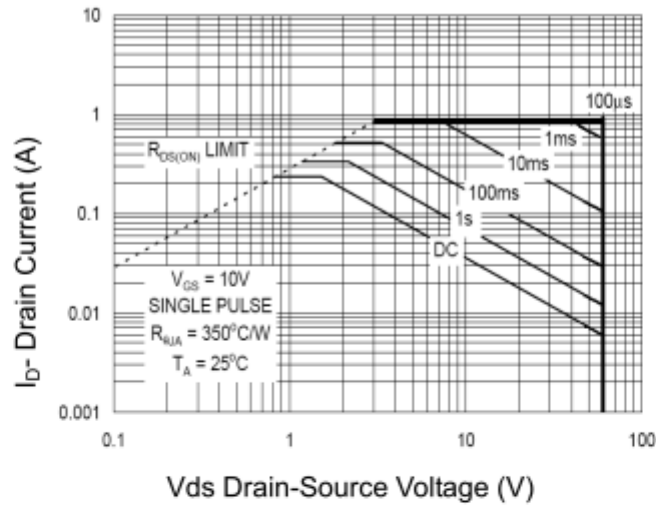

Figure 13 Safe Operation Area

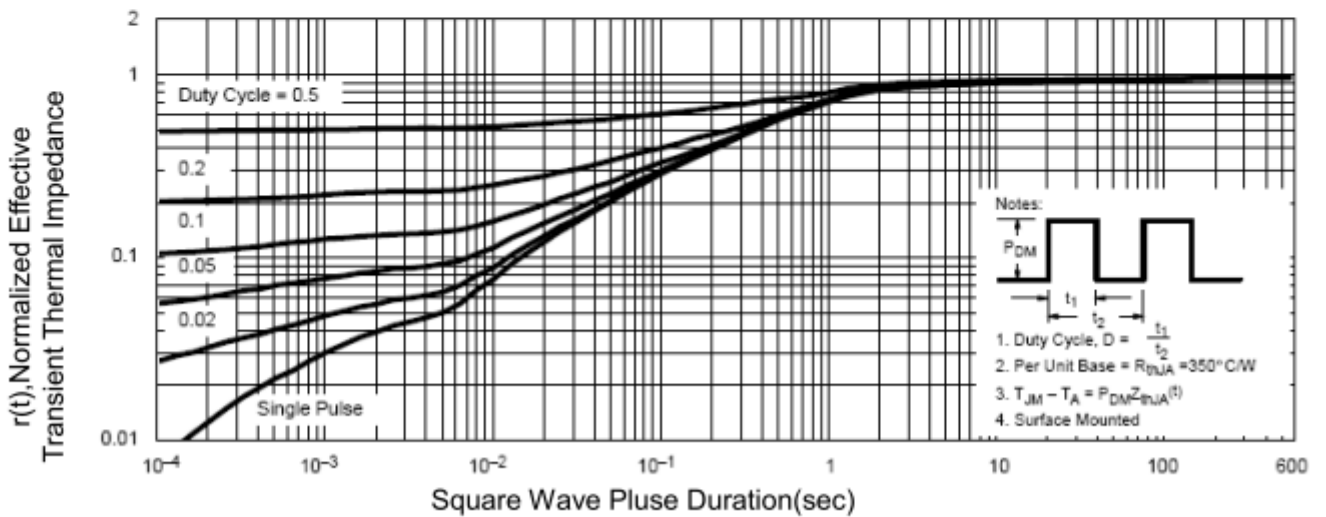
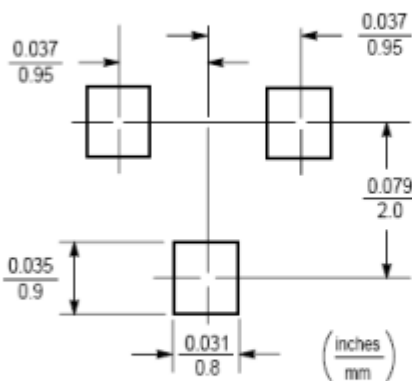
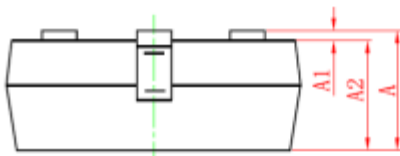
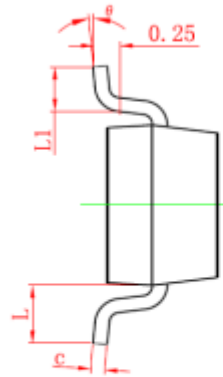
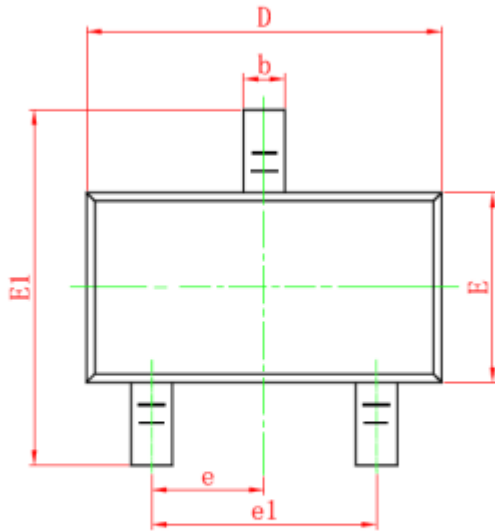

Figure 14 Normalized Maximum Transient Thermal Impedance

SOT23 Package Outline Dimension

Dimensions in Millimeters (UNIT:mm)



Symbol	Dimensions in Millimeters	
	MIN.	MAX.
A	0.900	1.150
A1	0.000	0.100
A2	0.900	1.050
b	0.300	0.500
c	0.080	0.150
D	2.800	3.000
E	1.200	1.400
E1	2.250	2.550
e	0.950TYP	
e1	1.800	2.000
L	0.550REF	
L1	0.300	0.500
θ	0°	8°

NOTES

1. All dimensions are in millimeters.
2. Tolerance $\pm 0.10\text{mm}$ (4 mil) unless otherwise specified
3. Package body sizes exclude mold flash and gate burrs. Mold flash at the non-lead sides should be less than 5 mils.
4. Dimension L is measured in gauge plane.
5. Controlling dimension is millimeter, converted inch dimensions are not necessarily exact.