



Description

P-channel MOSFET

Features

- $V_{DS} = -17V$, $I_D = -2.0A$
- $R_{DS(ON)} < 115m\Omega$ @ $V_{GS} = -4.5V$
 $R_{DS(ON)} < 165m\Omega$ @ $V_{GS} = -2.5V$
- High Power and Current Handling Capability
- Lead Free Product is Acquired
- Surface Mount Package

Application

- PWM Applications
- Load Switch
- Power Management

Package

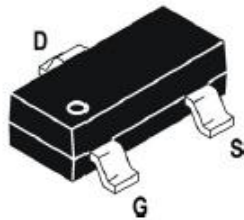

SOT-23

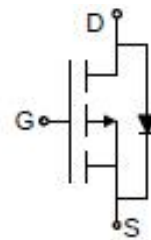

Schematic Diagram

Absolute Maximum Ratings (T_c=25°C unless otherwise specified)

Symbol	Parameter	Max.	Units
V _{DSS}	Drain-Source Voltage	-17	V
V _{GSS}	Gate-Source Voltage	±12	V
I _D	Continuous Drain Current	T _c = 25°C	-2.0
		T _c = 100°C	-1.4
P _D	Power Dissipation	T _A = 25°C	0.65
R _{θJA}	Thermal Resistance, Junction to Ambient	175	°C/W
T _J , T _{STG}	Operating and Storage Temperature Range	-55 to +150	°C



Electrical Characteristics (T_C=25°C unless otherwise specified)

Symbol	Parameter	Test Condition	Min.	Typ.	Max.	Units
Off Characteristic						
V _{(BR)DSS}	Drain-Source Breakdown Voltage	V _{GS} =0V, I _D = -250μA	-12	-17	-	V
I _{DSS}	Zero Gate Voltage Drain Current	V _{DS} = -15V, V _{GS} = 0V,	-	-	-1	μA
I _{GSS}	Gate to Body Leakage Current	V _{DS} = 0V, V _{GS} = ±12V	-	-	±100	nA
On Characteristics						
V _{GS(th)}	Gate Threshold Voltage	V _{DS} = V _{GS} , I _D = -250μA	-0.4	-0.6	-1.0	V
R _{DS(on)}	Static Drain-Source on-Resistance <small>note2</small>	V _{GS} = -4.5V, I _D = -1A	-	95	115	mΩ
		V _{GS} = -2.5V, I _D = -0.5A	-	120	165	
g _{FS}	Forward Transconductance	V _{DS} = -5V, I _D = -1.5A	4	-	-	S
Dynamic Characteristics						
C _{iss}	Input Capacitance	V _{DS} = -10V, V _{GS} = 0V f = 1.0MHz	-	332	-	pF
C _{oss}	Output Capacitance		-	69	-	pF
C _{rss}	Reverse Transfer Capacitance		-	42	-	pF
Q _g	Total Gate Charge	V _{DS} = -10V, I _D = -2.5A, V _{GS} = -4.5V	-	3.0	-	nC
Q _{gs}	Gate-Source Charge		-	0.58	-	nC
Q _{gd}	Gate-Drain("Miller") Charge		-	0.76	-	nC
Switching Characteristics						
t _{d(on)}	Turn-on Delay Time	V _{DD} = -10V, R _L =5Ω, R _{GEN} =3Ω, V _{GS} =-4.5V,	-	14	-	ns
t _r	Turn-on Rise Time		-	5.6	-	ns
t _{d(off)}	Turn-off Delay Time		-	21.5	-	ns
t _f	Turn-off Fall Time		-	7.9	-	ns
Drain-Source Diode Characteristics and Maximum Ratings						
I _s	Maximum Continuous Drain to Source Diode Forward Current		-	-	-2.0	A
V _{SD}	Drain to Source Diode Forward Voltage	V _{GS} = 0V, I _s = -2.0A	-	-	-1.3	V

Notes: 1. Repetitive Rating: Pulse Width Limited by Maximum Junction Temperature

2. Pulse Test: Pulse Width ≤ 300μs, Duty Cycle ≤ 2%



Typical Performance Characteristics

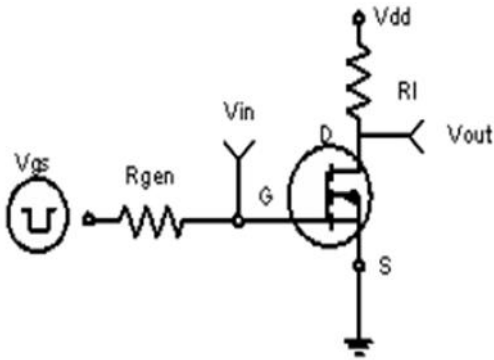

Figure1: Switching Test Circuit

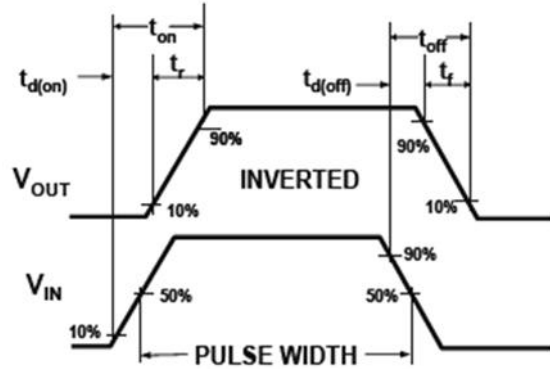
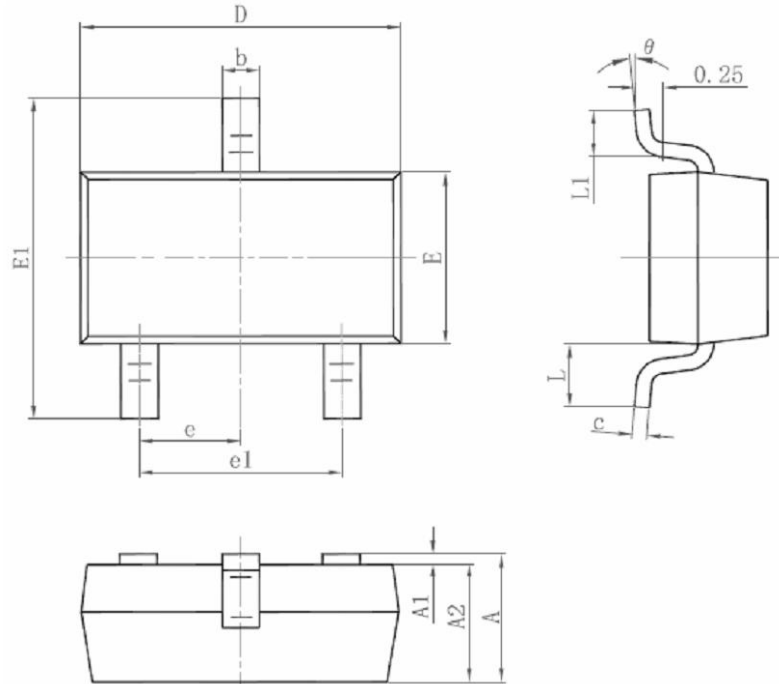

Figure2: Switching Waveforms



Package Information.

➤ SOT23-3(小)



符号	毫米		英寸	
	最小	最大	最小	最大
A	0.900	1.150	0.035	0.045
A1	0.000	0.100	0.000	0.004
A2	0.900	1.050	0.035	0.041
b	0.300	0.500	0.012	0.020
c	0.080	0.150	0.003	0.006
D	2.800	3.000	0.110	0.118
E	1.200	1.400	0.047	0.055
E1	2.250	2.550	0.089	0.100
e	0.950 TYP.		0.037 TYP.	
e1	1.800	2.000	0.071	0.079
L	0.550 REF.		0.022 REF.	
L1	0.300	0.500	0.012	0.020
θ	0°	8°	0°	8°