



SEMICONDUCTOR

P6KE6.8(C) A THRU P6KE600(C) A

TRANSIENT VOLTAGE SUPPRESSOR
PEAK PULSE POWER-600 Watts

FEATURES

- 600 Watts Pulse capability
- Excellent clamping capability
- Low incremental surge resistance
- Fast response time
- High temperature soldering guaranteed: 260°C/10 seconds at terminals
- Component in accordance to RoHS 2011/65/EU

MECHANICAL DATA

- Case: JEDEC DO-15 molded plastic body
- Terminals: Solder Plated
- Polarity: By cathode band denotes uni-directional device, none cathode band denotes bi-directional device.

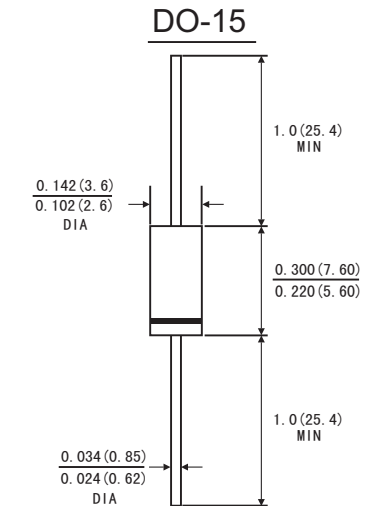

Dimensions in inches and (millimeters)

DEVICES FOR BIDIRECTIONAL APPLICATIONS

1. For bi-directional use C suffix for Types .
2. Electrical characteristics apply in both directions.

MAXIMUM RATINGS AND ELECTRICAL CHARACTERISTICS

(Rating at 25°C ambient temperature unless otherwise specified)

	Symbols	Value	Units
Peak Pulse Power Dissipation at on 10/1000µs Waveform (Note 1, 2)	P _{PK}	600	Watts
Peak forward surge current, 8.3ms single half sine-wave superimposed on rated load (JEDEC method) (Note 2, 3)	I _{FSM}	100	Amps
Operating junction and storage temperature range	T _J , T _{STG}	-55 to 150	°C

Note: 1. Non repetitive current pulse and derated above T_A=25°C

2. Measured on 8.3ms single half sine-wave or equivalent square wave, duty cycle=4 pulses per minute maximum

RATINGS AND CHARACTERISTIC CURVES (P6KE SERIES)

Part number		Reverse Standoff Voltage VRWM (Volts)	Breakdown Voltage VBR (Volts)		Test Current (mA)	Maximum Clamping Voltage VC@Ipp (Volts)	Maximum Peak Pulse Current Ipp(A)	Maximum Reverse Leakage IR@VRWM (μA)
UNI	BI		MIN	MAX				
P6KE6.8A	P6KE6.8CA	5.80	6.45	7.14	10.0	10.5	57.0	3σ 值
P6KE7.5A	P6KE7.5CA	6.40	7.13	7.88	10.0	11.3	53.0	3σ 值
P6KE8.2A	P6KE8.2CA	7.02	7.79	8.61	10.0	12.1	50.0	3σ 值
P6KE9.1A	P6KE9.1CA	7.78	8.65	9.55	1.0	13.4	45.0	3σ 值
P6KE10A	P6KE10CA	8.55	9.50	10.50	1.0	14.5	41.0	3σ 值
P6KE11A	P6KE11CA	9.87	10.50	11.60	1.0	15.6	38.0	1.0
P6KE12A	P6KE12CA	10.71	11.40	12.60	1.0	16.7	36.0	1.0
P6KE13A	P6KE13CA	11.66	12.40	13.70	1.0	18.2	33.0	1.0
P6KE15A	P6KE15CA	13.44	14.30	15.80	1.0	21.2	28.0	1.0
P6KE16A	P6KE16CA	14.28	15.20	16.80	1.0	22.5	27.0	1.0
P6KE18A	P6KE18CA	16.07	17.10	18.90	1.0	25.2	24.0	1.0
P6KE20A	P6KE20CA	17.96	19.00	21.00	1.0	27.7	22.0	1.0
P6KE22A	P6KE22CA	19.74	20.90	23.10	1.0	30.6	20.0	1.0
P6KE24A	P6KE24CA	21.53	22.80	25.20	1.0	33.2	18.0	1.0
P6KE27A	P6KE27CA	24.26	25.70	28.40	1.0	37.5	16.0	1.0
P6KE30A	P6KE30CA	26.88	28.50	31.50	1.0	41.4	14.4	1.0
P6KE33A	P6KE33CA	29.61	31.40	34.70	1.0	45.7	13.2	1.0
P6KE36A	P6KE36CA	32.34	34.20	37.80	1.0	49.9	12.0	1.0
P6KE39A	P6KE39CA	34.97	37.10	41.00	1.0	53.9	11.2	1.0
P6KE43A	P6KE43CA	38.64	40.90	45.20	1.0	59.3	10.1	1.0
P6KE47A	P6KE47CA	42.21	44.70	49.40	1.0	64.8	9.3	1.0
P6KE51A	P6KE51CA	45.78	48.50	53.60	1.0	70.1	8.6	1.0
P6KE56A	P6KE56CA	50.19	53.2	58.8	1.0	77.0	7.80	1.0
P6KE62A	P6KE62CA	55.65	58.9	65.1	1.0	85.0	7.10	1.0
P6KE68A	P6KE68CA	61.01	64.6	71.4	1.0	92.0	6.50	1.0
P6KE75A	P6KE75CA	67.31	71.3	78.8	1.0	103.0	5.80	1.0
P6KE82A	P6KE82CA	73.61	77.9	86.1	1.0	113.0	5.30	1.0
P6KE91A	P6KE91CA	81.69	86.5	95.5	1.0	125.0	4.80	1.0
P6KE100A	P6KE100CA	89.78	95.0	105.0	1.0	137.0	4.40	1.0
P6KE110A	P6KE110CA	98.70	105.0	116.0	1.0	152.0	4.00	1.0
P6KE120A	P6KE120CA	107.10	114.0	126.0	1.0	165.0	3.60	1.0

RATINGS AND CHARACTERISTIC CURVES (P6KE SERIES)

P6KE130A	P6KE130CA	116.55	124.0	137.0	1.0	179.0	3.30	1.0
P6KE150A	P6KE150CA	134.40	143.0	158.0	1.0	207.0	2.90	1.0
P6KE160A	P6KE160CA	142.80	152.0	168.0	1.0	219.0	2.70	1.0
P6KE170A	P6KE170CA	152.25	162.0	179.0	1.0	234.0	2.60	1.0
P6KE180A	P6KE180CA	161.70	171.0	189.0	1.0	246.0	2.40	1.0
P6KE200A	P6KE200CA	179.55	190.0	210.0	1.0	274.0	2.20	1.0
P6KE220A	P6KE220CA	194.25	209.0	231.0	1.0	328.0	1.83	1.0
P6KE250A	P6KE250CA	224.70	237.0	263.0	1.0	344.0	1.75	1.0
P6KE300A	P6KE300CA	268.80	285.0	315.0	1.0	414.0	1.45	1.0
P6KE350A	P6KE350CA	315.00	332.0	368.0	1.0	482.0	1.25	1.0
P6KE400A	P6KE400CA	359.10	380.0	420.0	1.0	548.0	1.10	1.0
P6KE440A	P6KE440CA	394.80	418.0	462.0	1.0	602.0	1.00	1.0
P6KE500A	P6KE500CA	427.5	475.0	525.0	1.0	690.0	0.87	1.0
P6KE520A	P6KE520CA	444.6	494.0	546.0	1.0	717.6	0.84	1.0
P6KE550A	P6KE550CA	470.3	522.5	577.5	1.0	759.0	0.79	1.0
P6KE600A	P6KE600CA	513.0	570.0	630.0	1.0	828.0	0.72	1.0

For Bi-directional type having VRWM of 10 Volts and less, the IR limit is double

- 1.A transient suppressor is normally selected according to the working peak reverse voltage (VRWM), which should be equal to or greater than the DC or continuous peak operating voltage level.
- 2.VBR measured at pulse test current IT at an ambient temperature of 25°C.
- 3.Surge current waveform per Figure 2 and derate per Figure 3

RATINGS AND CHARACTERISTIC CURVES (P6KE SERIES)

FIG. 1-PEAK PULSE POWER CURVE

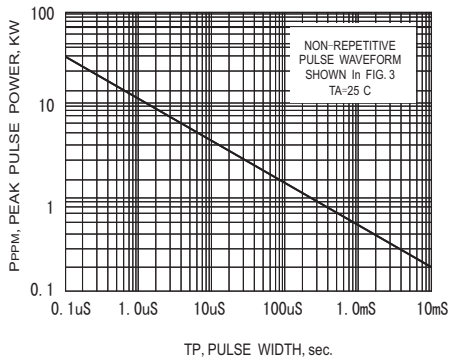

FIG. 2-PULSE DERATING CURVE

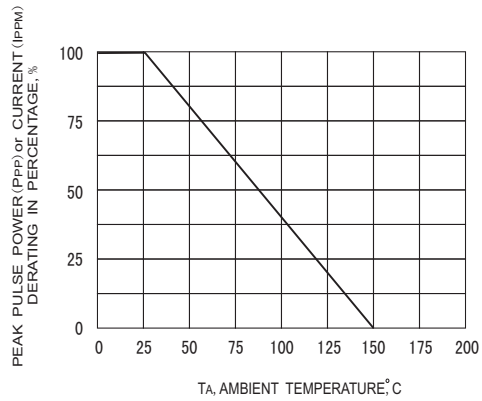

FIG. 3-PULSE WAVEFORM

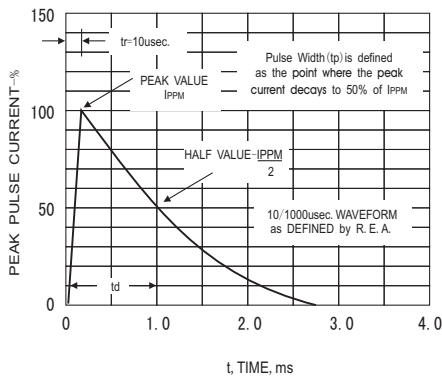

FIG. 4-MAXIMUM NON-REPETITIVE PEAK FORWARD SURGE CURRENT

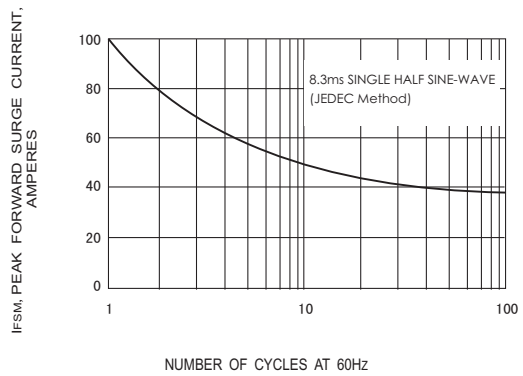

FIG. 5-Steady State Power Derating Curve

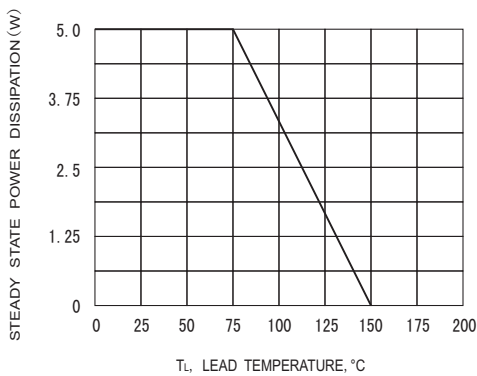

FIG. 6-TYPICAL JUNCTION CAPACITANCE

