

10 Gigabit XFP Serial Hot-Pluggable Transceiver

The Infineon 10G XFP transceiver series is a family of high-performance, low-cost modules for serial optical data communication applications. The modules are protocol-agnostic, ultra-small 10 Gbit/s optical transceivers that comply with all applicable IEEE 802.3ae 10 Gigabit Ethernet and NCITS 10 Gigabit Fibre Channel standards.

Infineon's small-form-factor 10 Gigabit XFP transceivers are fully compliant with the specifications of the XFP MSA (Multi-Source Agreement).

The XFP series includes an 850 nm wavelength version for short-reach applications of up to 300 m and a 1310 nm version for applications of up to 10 km in range.

Infineon's XFP modules allow communications equipment manufacturers to create standard-based, high-bandwidth systems to meet the requirements of 10GE, 10GFC and OC-192 applications, including server network interface cards, host bus adapters, target channel adapters and SAN and enterprise LAN switches.

The modules are designed for high-density applications. Configurations of up to 16 modules in a 19-inch rack space are possible without compromising the stringent thermal and EMI management requirements with 10 Gbit/s optical electronics devices.

Applications

- Fibre Channel SAN switches
- Ethernet LAN switches
- Fibre Channel host bus adapters
- Ethernet network interface cards
- Hubs, bridges, routers
- SONET/SDH/ATM switches



Features

- Full-duplex transmission at 9.95 to 11.08 Gbit/s
- Transceiver options:
 - 850 nm VCSEL for a range up to 300 m over multi-mode fiber
 - 1310 nm DFB laser for up to 10 km over single-mode fiber
- Protocol-transparent
- 2-wire interface for integrated Digital Optical Monitoring
- Serial 10 Gbit/s XFI electrical interface
- User-friendly plug-and-play-style "Hot Swap"
- Power consumption less than 2.5 W
- 5 V, 3.3 V and 1.8 V power supply
- Integrated transmit and receive CDR
- IEC 60825-1 class 1 and FDA 21 CFR 1040.10 and 1040.11 laser eye safety
- ESD class 2 per MIL-STD 883D method 3015.7
- FCC 47 CFR class B

www.infineon.com/fiberoptics



Never stop thinking.

Products

Ordering code	Wave length	Reach	Optical connect
V23833-F0005-B101	850 nm	300 m*	LC
V23833-F0105-B001	1310 nm	10 km	LC

* Using 50 µm multi-mode fiber with 2000 MHz*km bandwidth

Accessories

Ordering code	Product	Description
V23833-F9909-Z001	XFP evaluation board kit	Test board with 30-Pin XFP connector and cage

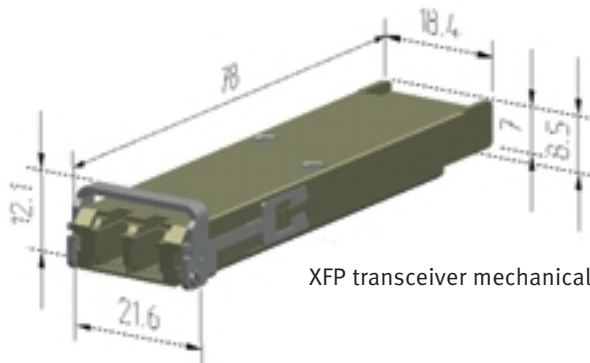

XFP transceiver mechanical package [mm]

XFP transceiver block diagram

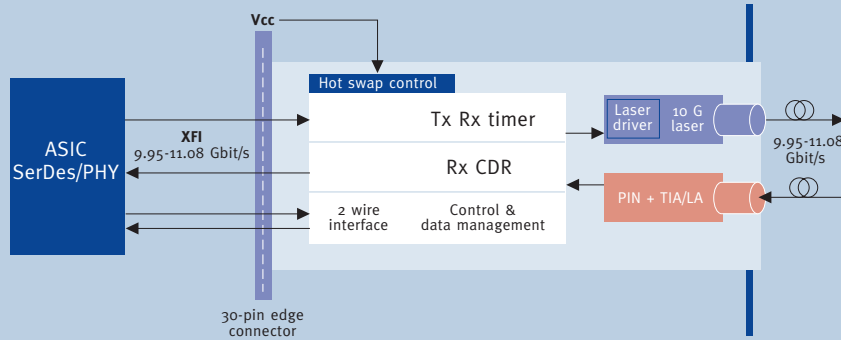

For more information, please contact:

Infinion Technologies

North America (CA):
Irene Yan
Phone: +1-408-501-5664
irene.yan@infineon.com

Europe (Germany):
Angela Scholl
Phone: +49-30-386-22521
angela.scholl@infineon.com

Asia (Hong Kong):
Owen Chui
Phone: +852-2832-048
owen.chui@infineon.com

Japan (Tokyo):
Kunikazu Watanabe
Phone: +81-3-5449-6705
kunikazu.watanabe@infineon.com

Edition September 2003

Published by Infineon Technologies AG,
St.-Martin-Straße 53,
D-81669 München

© Infineon Technologies AG 2003.
All Rights Reserved.

Please note:

The information herein describes certain components and shall not be considered as a guarantee of characteristics. Terms of delivery and rights to technical change reserved. We hereby disclaim any and all warranties, including but not limited to warranties of non-infringement regarding circuits, descriptions and charts stated herein. Infineon Technologies is an approved CECC manufacturer.

Information

For further information on technology, delivery terms and conditions and prices, please contact your nearest Infineon Technologies office in Germany or our Infineon Technologies representatives worldwide (www.infineon.com).

Warnings

Due to technical requirements, components may contain dangerous substances. For information on the types in question please contact your nearest Infineon Technologies office.

Infinion Technologies components may only be used in life-support devices or systems with the express written approval of Infineon Technologies if a failure of such components can reasonably be expected to cause the failure of that life-support device or system, or to affect the safety or effectiveness of that device or system. Life-support devices or systems are intended to be implanted in the human body, or to support and/or maintain and sustain and/or protect human life. If they fail, it is reasonable to assume that the health of the user or other persons may be endangered.