

Features

- Surface Mount
- No Wire Bonding Required
- Rugged Silicon-Glass Construction
- Silicon Nitride Passivation
- Polymer Scratch Protection
- Low Parasitic Capacitance and Inductance
- High Average and Peak Power Handling
- RoHS Compliant

Description

This device is a Silicon-Glass PIN diode chip fabricated with M/A-COM Tech's patented HMIC™ process. This device features two silicon pedestals embedded in a low loss, low dispersion glass. The diode is formed on the top of one pedestal and connections to the backside of the device are facilitated by making the pedestal sidewalls electrically conductive. Selective backside metallization is applied producing a surface mount device. This vertical conic topology provides for exceptional heat transfer from the active area. The topside is fully encapsulated with silicon nitride and has an additional polymer layer for scratch and impact protection. These protective coatings prevent damage to the junction and the anode air-bridge during handling and assembly.

Absolute Maximum Ratings

T_{AMB} = 25°C (unless otherwise specified)

Parameter	Absolute Maximum
Forward Current	600mA
Reverse Voltage	-100V
Operating Temperature	-55°C to +125°C
Storage Temperature	-55 °C to +150°C
Junction Temperature	+175°C
Dissipated Power (RF & DC)	800mW
Mounting Temperature	+260°C for 30 seconds

MA4SPS302

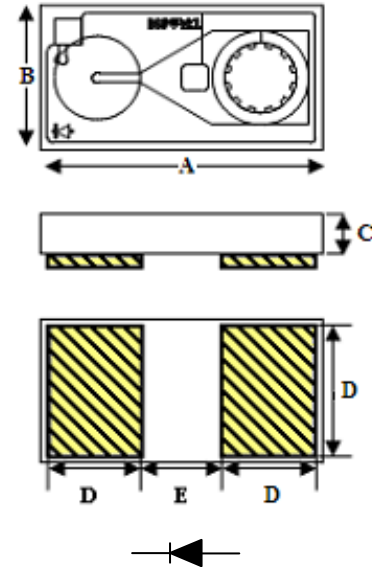

1. Backside metal: 0.1 μM thick.
2. Yellow hatched areas indicate backside ohmic gold

DIM	INCHES		MM	
	Min.	Max.	Min.	Max.
A	0.052	0.056	1.321	1.422
B	0.020	0.024	0.508	0.610
C	0.004	0.006	0.102	0.152
D	0.018	0.020	0.457	0.508
E	0.014	0.016	0.356	0.406

Electrical Specifications @ T_{AMB} = +25°C

Symbol	Conditions	Units	Min	Typ	Max
C _T ¹	-40V, 1MHz	pF		0.40	0.45
C _T ^{1,3}	-40V, 1GHz	pF		0.36	
R _S ^{2,3}	10mA, 100MHz	W		1.3	2.2
V _F	10mA	V		0.84	1.00
V _R	-10μA	V	-70	-100	
I _R	-70 V	nA		100	1000
R _{qJL} ⁴	I _H =1A, I _L =10mA	°C/W		125	
TL	+10mA / -6mA	ns		460	

1. Total Capacitance, C_T, is equivalent to the sum of Junction Capacitance and Parasitic Capacitance.
C_T = C_J (Junction Capacitance) + C_{PAR} (Parasitic Capacitance)
2. Series resistance R_S is equivalent to the total diode resistance:
R_S = R_J (Junction Capacitance Junction Resistance) + R_O (Ohmic Resistance)
3. R_S and C_T are measured on an HP4291A Impedance Analyzer with die mounted in an ODS-186 package with conductive silver epoxy.

R_s vs. Forward Current and Frequency

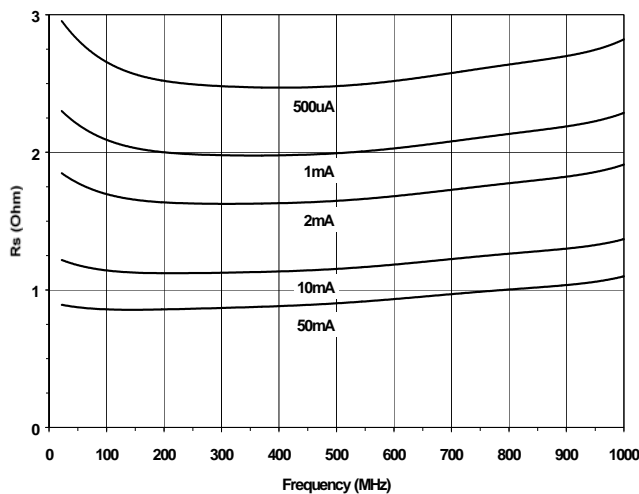

C_T vs. Reverse Voltage and Frequency

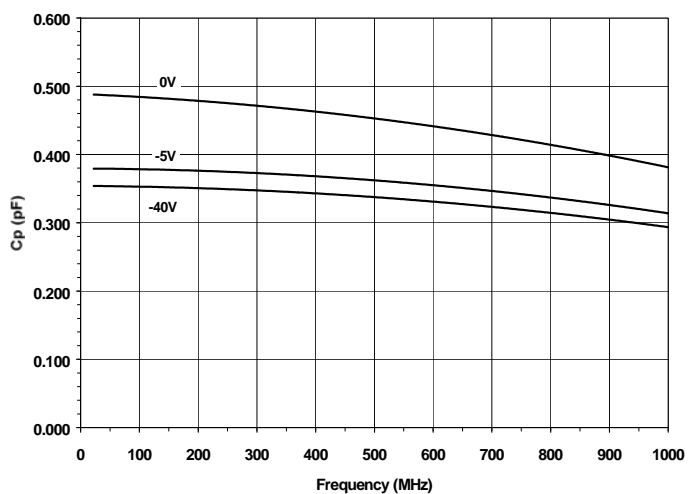

2

ADVANCED: Data Sheets contain information regarding a product M/A-COM Technology Solutions is considering for development. Performance is based on target specifications, simulated results, and/or prototype measurements. Commitment to develop is not guaranteed.

PRELIMINARY: Data Sheets contain information regarding a product M/A-COM Technology Solutions has under development. Performance is based on engineering tests. Specifications are typical. Mechanical outline has been fixed. Engineering samples and/or test data may be available. Commitment to produce in volume is not guaranteed.

• **North America** Tel: 800.366.2266 • **Europe** Tel: +353.21.244.6400
• **India** Tel: +91.80.43537383 • **China** Tel: +86.21.2407.1588

Visit www.macomtech.com for additional data sheets and product information.

M/A-COM Technology Solutions Inc. and its affiliates reserve the right to make changes to the product(s) or information contained herein without notice.

MA4SPS302 ADS SPICE Model & Schematic

MA4SPS302 SPICE Model

PinDiodeModel	wBv=100 V
NLPINM1	wPmax=0.8 W
Is=1.0E-14 A	Ffe=1.0
Vi=0.0 V	
Un=900 cm ² /V-sec	
Wi=6.5 um	
Rr=20 K Ohm	
Cmin=0.40 pF	
Tau=0.20 usec	
Rs=0.1 Ohm	
Cj0=0.50 pF	
Vj=0.7 V	
M=0.5	
Fc=0.5	
Imax=1.0E+6 A/m ²	
Kf=0.0	
Af=1.0	

MA4SPS302 Schematic

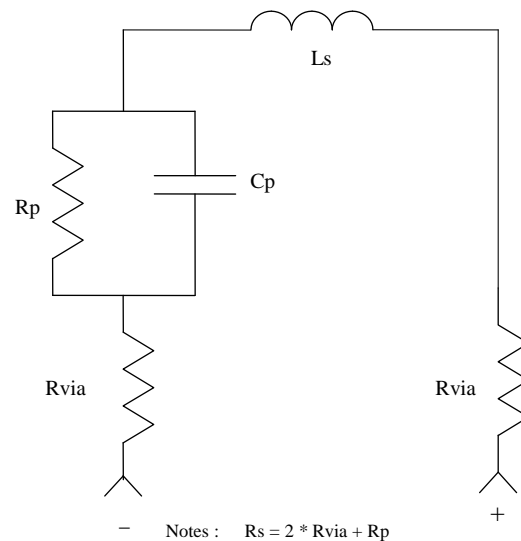

Notes : $R_s = 2 * R_{via} + R_p$

Handling

All semiconductor chips should be handled with care to avoid damage or contamination from perspiration and skin oils. The use of plastic tipped tweezers or vacuum pickups is strongly recommended for individual components. Bulk handling should insure that abrasion and mechanical shock are minimized.

Die Attach

Attachment to a circuit board is made simple through the use of surface mount technology. Mounting pads are conveniently located on the bottom surface of these devices and are removed from the active junction locations. These devices are well suited for solder attachment onto hard and soft substrates. The use of 80/20, Au/Sn, 60/40, Sn/Pb or RoHS compliant solders is recommended. Conductive silver epoxy solder may also be used but could result in an increase in series and thermal resistance.

When soldering these devices to a hard substrate, hot gas die bonding is preferred. We recommend utilizing a vacuum tip and force of 60 to 100 grams applied to the top surface of the device. When soldering to soft substrates, it is recommended to use a lead-tin interface at the circuit board mounting pads. Position the die so that its mounting pads are aligned with the circuit board mounting pads and reflow the solder by heating the circuit trace near the mounting pads while applying 60 to 100 grams of force perpendicular to the top surface of the die. The solder joint must not be made one pad at a time. Doing so could create unequal heat flow and produce thermal and/or mechanical stresses to the die. It is also not recommended to reflow solder by causing heat to flow through the top surface of the die. Since the HMIC glass is transparent, the edges of the mounting pads can be visually inspected through the die after attach is completed.

Recommended temperature and re-flow profiles for 60/40, Sn/Pb and RoHS compliant solders are provided in [Application Note M538](#), "Surface Mounting Instructions". [Application Note M541](#) "Bonding and Handling Procedures for Chip Diode Devices" provides handling and assembly recommendations.

Ordering Information

The MA4SPS302 SURMOUNT are packaged in gel packs.

Part Number
Gel Pack
MA4SPS302