

Coaxial Bandpass Filter

ZABP-184+

50Ω 154.32 to 214.32 MHz

The Big Deal

- Broad bandwidth
- High Rejection
- Good VSWR
- Connectorized package



CASE STYLE: UU1842

Product Overview

ZABP-184+ is a 50Ω bandpass filter with a rugged connectorized package covering the passband of 154.32 to 214.32 MHz. The bandpass filter offers good matching within the passband and provides high rejection. This filter has miniature high Q capacitors and wire welded inductors for high reliability. It has repeatable performance across lots and consistent performance across temperature.

Key Features

Feature	Advantages
High rejection	ZABP-184+ has sharper transition and rejects spurious signals in the stopband.
Good VSWR	This filter maintains typical VSWR over passband frequency range making this filter easier to integrate into receiver and transmitter RF chains with less concerns for in band frequency ripple.
Connectorized package	Connectorized package is easy to interface with other devices and well suited for test setups.

Notes

- A. Performance and quality attributes and conditions not expressly stated in this specification document are intended to be excluded and do not form a part of this specification document.
B. Electrical specifications and performance data contained in this specification document are based on Mini-Circuit's applicable established test performance criteria and measurement instructions.
C. The parts covered by this specification document are subject to Mini-Circuits standard limited warranty and terms and conditions (collectively, "Standard Terms"); Purchasers of this part are entitled to the rights and benefits contained therein. For a full statement of the Standard Terms and the exclusive rights and remedies thereunder, please visit Mini-Circuits' website at www.minicircuits.com/MCLStore/terms.jsp



Coaxial Bandpass Filter

ZABP-184+

50Ω 154.32 to 214.32 MHz



CASE STYLE: UU1842
Connectors SMA-MF Model ZABP-184-S+

Features

- Broad bandwidth
- High rejection
- Good VSWR
- Connectorized package

Applications

- Digital television
- Biomedical telemetry device
- Wireless microphone
- Test equipment

Electrical Specifications at 25°C

Parameter	F#	Frequency (MHz)	Min.	Typ.	Max.	Unit	
Pass Band	Center Frequency	-	-	184	-	MHz	
	Insertion Loss	F1-F2	154.32 - 214.32	-	1.9	3.0	dB
	VSWR	F1-F2	154.32 - 214.32	-	1.4	1.9	:1
Stop Band, Lower	Insertion Loss	DC-F3	DC - 139	20	30	-	dB
	VSWR	DC-F3	DC - 139	-	20	-	:1
Stop Band, Upper	Insertion Loss	F4-F5	242 - 750	20	27	-	dB
		F5-F6	750 - 1400	60	79	-	dB
	F6-F7	1400 - 2500	50	60	-	dB	
	F7-F8	2500 - 3500	-	20	-	dB	
	VSWR	F4-F8	242 - 3500	-	20	-	:1

Maximum Ratings

Operating Temperature	-40°C to 85°C
Storage Temperature	-55°C to 100°C
RF Power Input	2 W max.

Permanent damage may occur if any of these limits are exceeded.

Functional Schematic

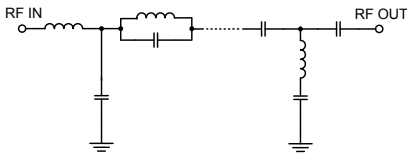

Typical Performance Data at 25°C

Frequency (MHz)	Insertion Loss (dB)	VSWR (:1)	Frequency (MHz)	Group Delay (ns)
1.00	77.69	4919.23	154.32	29.65
50.00	44.89	654.25	155.00	27.68
139.00	33.31	31.85	160.00	21.55
140.00	28.58	27.95	162.00	19.85
142.00	20.74	19.78	164.00	18.49
149.00	3.05	1.69	166.00	17.39
151.00	2.10	1.07	168.00	16.54
154.32	1.66	1.18	170.00	15.89
184.00	1.21	1.07	175.00	14.85
214.32	1.84	1.36	180.00	14.29
218.00	2.02	1.20	182.00	14.12
223.00	3.04	1.68	184.00	13.99
236.00	20.19	26.47	185.00	13.93
242.00	30.89	45.12	190.00	13.80
750.00	93.71	144.40	192.00	13.83
1400.00	84.23	130.59	195.00	13.99
2500.00	61.97	42.16	200.00	14.57
2800.00	57.36	38.76	205.00	15.54
3000.00	53.32	36.50	210.00	16.92
3500.00	45.78	26.26	214.32	19.09

Typical Frequency Response

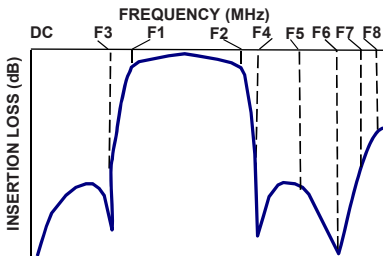

+RoHS Compliant

The +Suffix identifies RoHS Compliance. See our web site for RoHS Compliance methodologies and qualifications

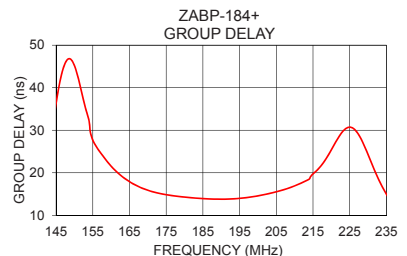
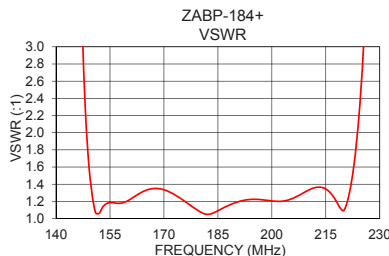
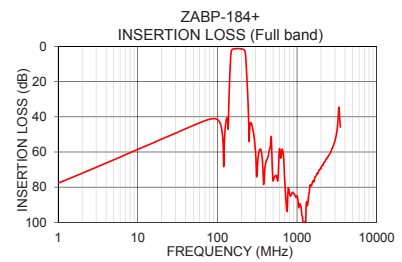
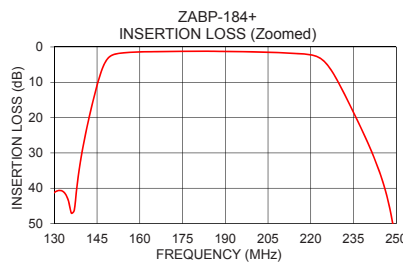

Notes

- Performance and quality attributes and conditions not expressly stated in this specification document are intended to be excluded and do not form a part of this specification document.
- Electrical specifications and performance data contained in this specification document are based on Mini-Circuits' applicable established test performance criteria and measurement instructions.
- The parts covered by this specification document are subject to Mini-Circuits standard limited warranty and terms and conditions (collectively, "Standard Terms"); Purchasers of this part are entitled to the rights and benefits contained therein. For a full statement of the Standard Terms and the exclusive rights and remedies thereunder, please visit Mini-Circuits' website at www.minicircuits.com/MCLStore/terms.jsp



Coaxial Connections

INPUT	SMA-FEMALE
OUTPUT	SMA-MALE

Outline Drawing

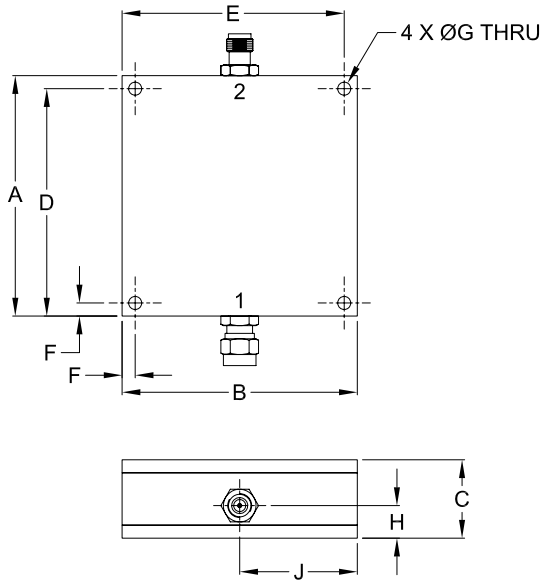

Outline Dimensions ($\frac{\text{inch}}{\text{mm}}$)

A	B	C	D	E
2.300	2.250	.750	2.175	2.125
58.42	57.15	19.05	55.25	53.98
F	G	H	J	wt.
.125	.125	.312	1.125	grams
3.18	3.18	7.93	28.58	124

Notes

- A. Performance and quality attributes and conditions not expressly stated in this specification document are intended to be excluded and do not form a part of this specification document.
 B. Electrical specifications and performance data contained in this specification document are based on Mini-Circuit's applicable established test performance criteria and measurement instructions.
 C. The parts covered by this specification document are subject to Mini-Circuits standard limited warranty and terms and conditions (collectively, "Standard Terms"); Purchasers of this part are entitled to the rights and benefits contained therein. For a full statement of the Standard Terms and the exclusive rights and remedies thereunder, please visit Mini-Circuits' website at www.minicircuits.com/MCLStore/terms.jsp

