



REV A January 2011

Oscilent Controlled Document

Ordering Code / Part Number	Product Description
820-IF70.0M-S	70.0 MHz IF SAW Filter 4.3 MHz Bandwidth

### Specification Contents

- o Mechanical Dimensions
- o Test Circuit
- o Maximum Ratings
- o Electrical Specification
- o Frequency Response
- o Smith Chart
- o VSWR

### Notes

- o Electrostatic Sensitive Device (ESD) 
- o Avoid excessive ultrasonic exposure
- o Solderability compatible with JEDEC J-STD-020C Pb-free process, 260°C peak reflow temperature
- o This product complies with EU directive 2002/95/EC (RoHS compliance)





**Mechanical Dimensions (mm)**

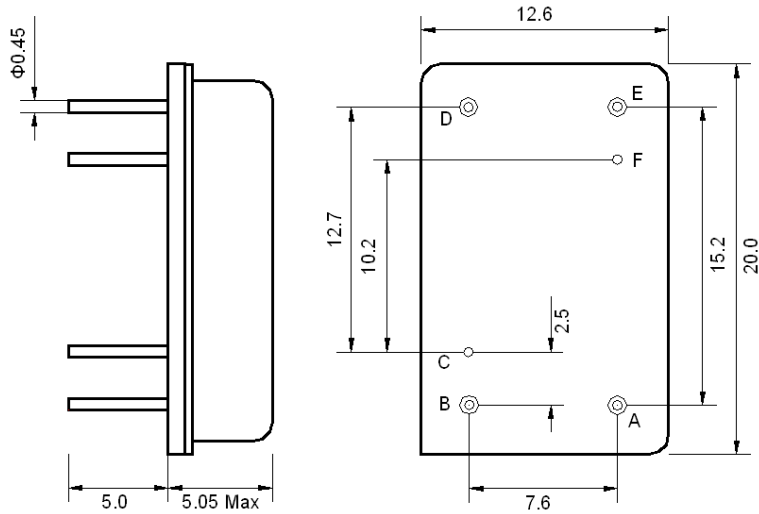

Pin Description	
B, C, E, F	Ground
A	Input
D	Output

**Test Circuit**

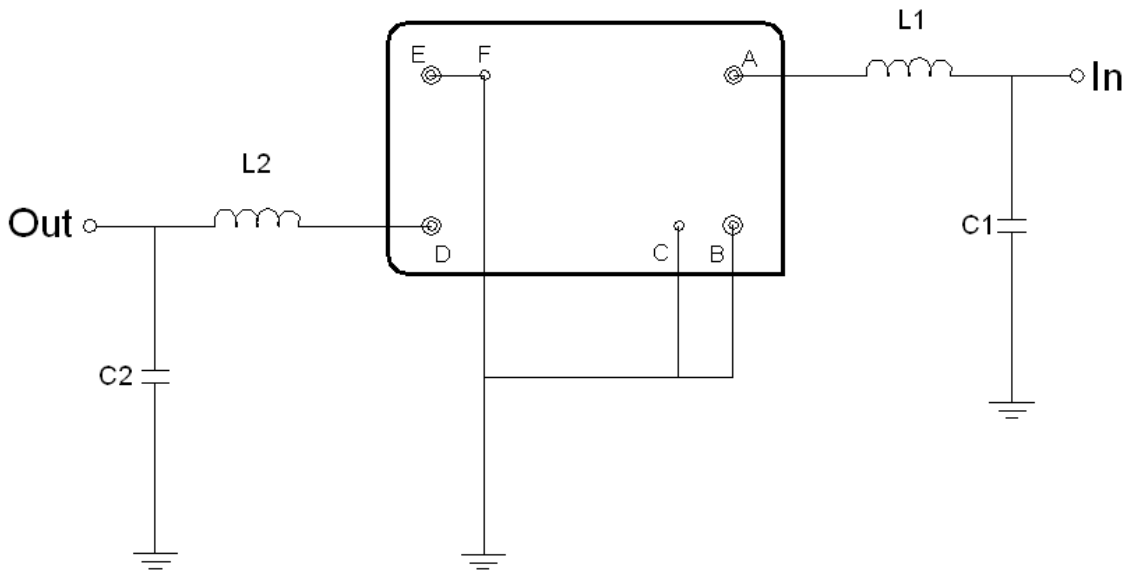

Test Fixture & Values	
Input	L1 = 68 nH, C1 = 100 pF
Output	L2 = (82+8.2) nH, C2 = 82 pF
Source/Load Impedance	50 Ω



## Maximum Ratings

Parameters Description	Unit	Minimum	Typical	Maximum
Operating Temperature Range	°C	-30	-	+80
Storage Temperature Range	°C	-40	-	+85
Maximum DC Voltage	V	-	-	10
Maximum Input Power	dBm	-	-	10
Source Impedance (single ended) <sup>(1)</sup>	Ω	-	50	-
Load Impedance (single ended) <sup>(1)</sup>	Ω	-	50	-

Notes: With Matching Network (Ref. Testing Environment Circuit as shown above).  
Those impedances could be modified with different impedance values and/or structures, if necessary.

## Electrical Specification

Parameters Description	Unit	Minimum	Typical	Maximum
Center Frequency (Fo)	MHz	69.90	70.00	70.10
Insertion Loss at Fo	dB	-	20.5	23.0
Group Delay Variation	nsec	-	100	150
Absolute Delay at Fo	usec	-	2.46	-
Passband Ripple Variation	dB	-	0.7	1.0
Bandwidth at -1dB	MHz	4.0	4.3	-
Bandwidth at -3dB	MHz	4.4	4.5	-
Bandwidth at -40dB	MHz	-	5.4	5.6
Ultimate Rejection	dB	45	50	-
Temperature Coefficient	ppm/°C	-	-23	-



## Frequency Response

### Bandwidth at -1.0 dB

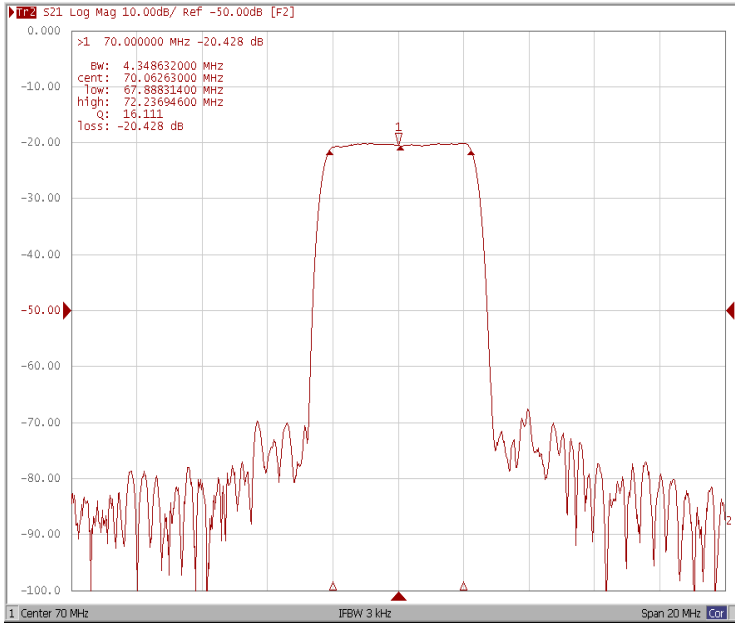

### Bandwidth at -3.0 dB

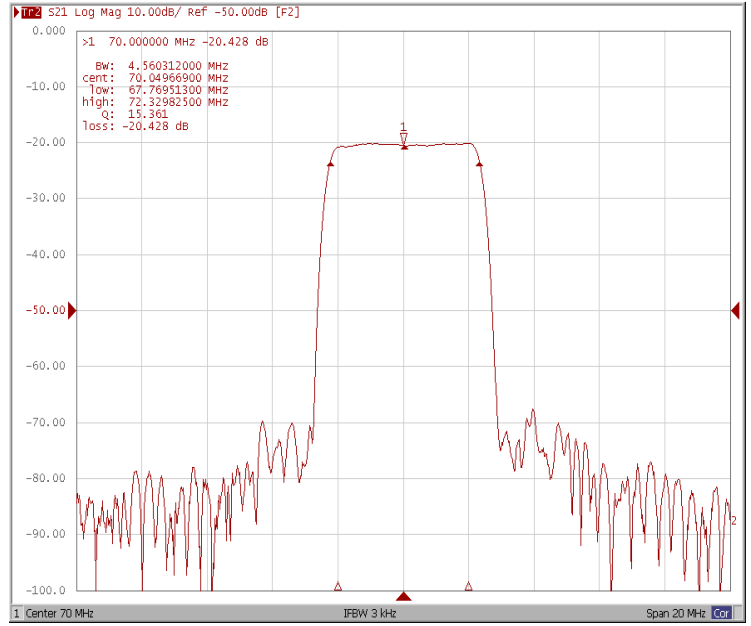

### Bandwidth at -40.0 dB

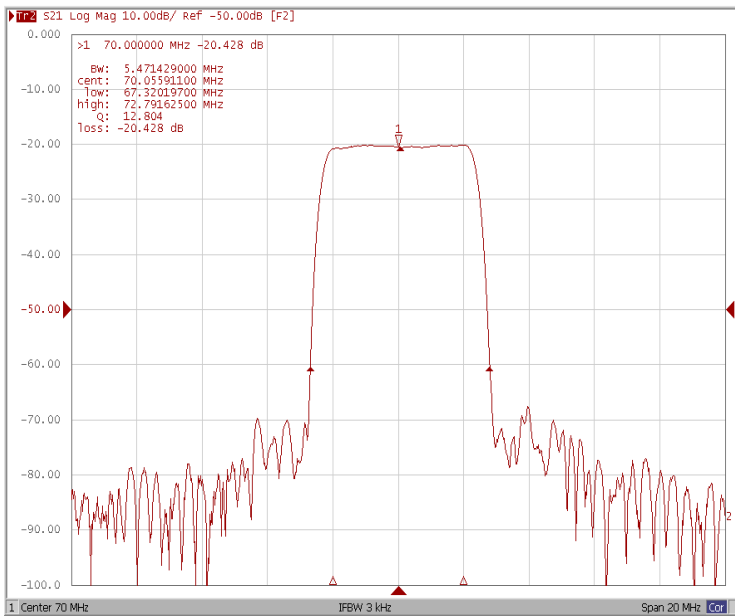

### Wide-Band

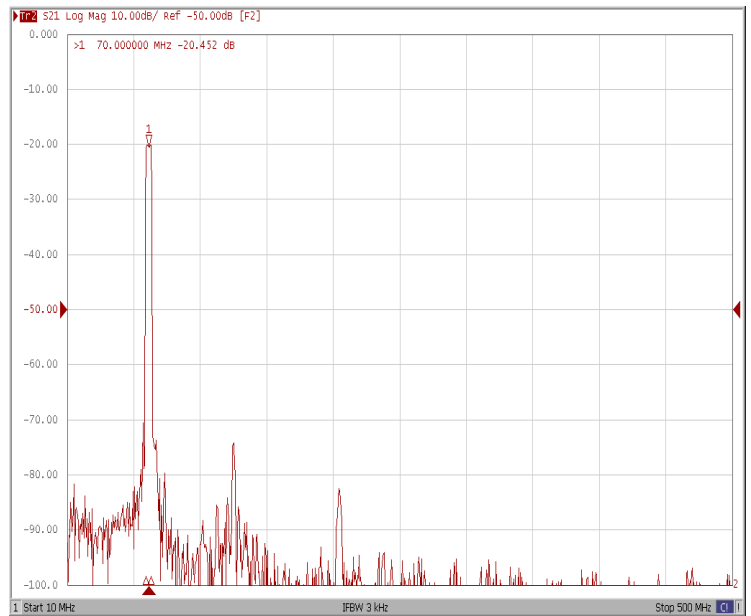



### Ripple Variation Fo±2.0MHz

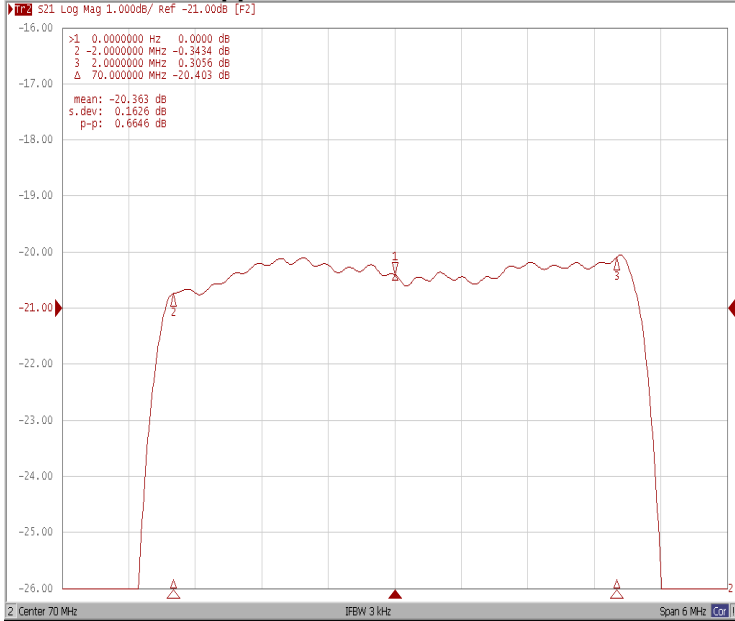

### Group Delay Variation Fo±2.0MHz

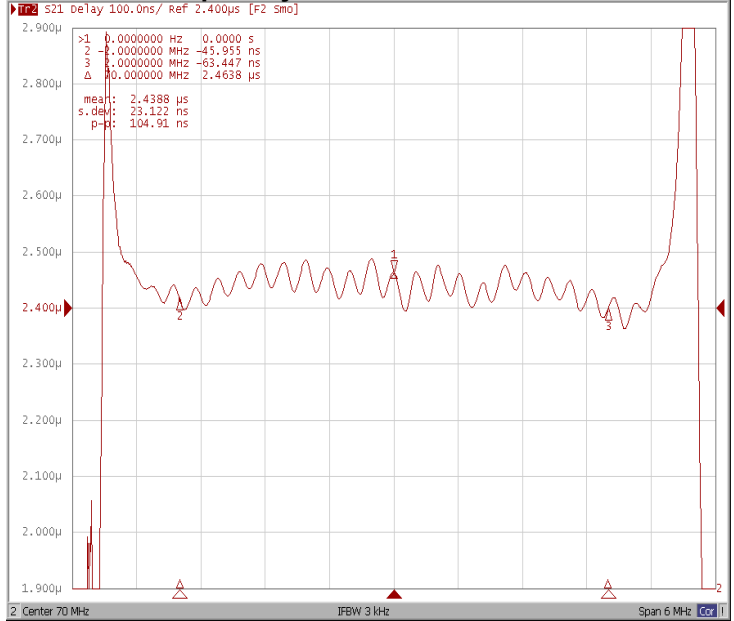

### Smith Chart

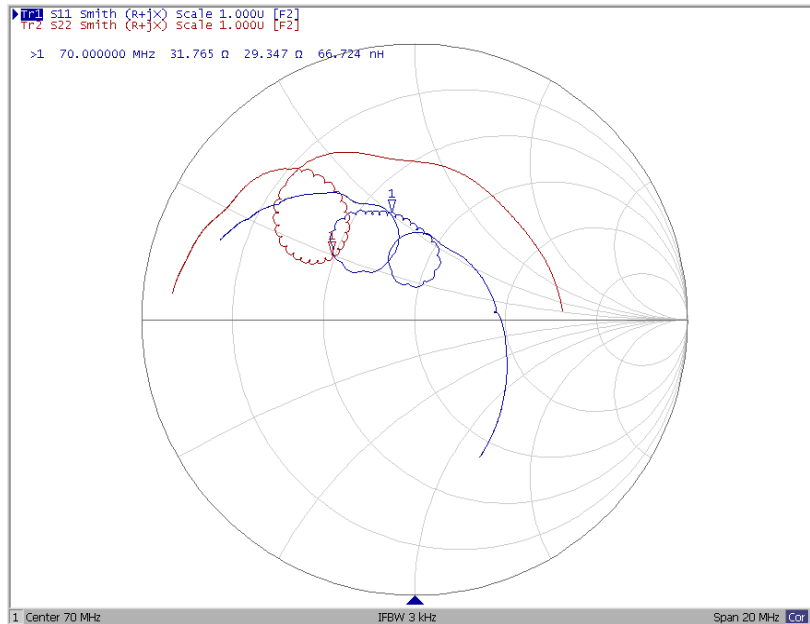



### VSWR

